

Digital innovations to enable scale in the domestic retrofit market

Helen Williams

Programme Manager, National Home Energy Upgrade Scheme

Agenda

	Title	Presenter
2:30 pm – 2:35 pm	Introduction	Helen Williams, SEAI
2:35 pm – 2:50 pm	Survey data in modular retrofit	Patrick Daly, TU Dublin
2:50 pm – 3:05 pm	Digital Processes for Inspecting Retrofit Works	Mel McGerr, MMA Architects
3:05 pm – 3:20 pm	Product demonstration	Liam Donohue, Retrokit
3:20 pm – 3:35 pm	Product demonstration	Michael Hanratty, BERWOW
3:35 pm – 3:50 pm	Product demonstration	David Sheil, Prime19
3:50 pm – 4:00 pm	NAS API	Kevin Raheem, SEAI

Survey and Data Issues in Modular Retrofit

Developing and piloting a modular circular wall panel system for application in retrofit of social housing

Patrick Daly

School of Architecture Building and Environment

TUDublin



Personal Introduction

Patrick Daly

Background in Architectural Technology and Project Management

MSc Architecture Advanced Energy & Environmental Studies
MSc Research Sustainability in the Built Environment

Specialism in Sustainability in Built Environment

Energy Efficiency - Fabric and Building Energy Analysis – Modelling and Simulation

Environmental Design – Alternative Construction, Materials and Impacts

Developing an interest in Circularity

Lecturer Researcher in the SABE TUDublin

Principle Lecturer on MSc EED Building Performance

PI Drive 0 Irish Demonstrator

Tech Committee IGBC EPA Circularity Road Map



patrick.daly@TUDublin.ie

pd@patrickdaly.net

Patrick Daly
Dip Arch Tech, B Ed Des Tech, Dip Pro Man, MSc AEES, MSc Built Enviro

Presentation Overview

Drive 0 Intro / Demonstrator Case

Modular System

Survey 1

Design Development & Mock Up

Survey 2

Production

Installation

Lessons Learnt



DRIVE 0 <https://www.drive0.eu/>
H2020 EU Project

Driving decarbonization of the EU building stock by enhancing a consumer centred and locally based circular renovation process 7 specific study and demonstration cases as real environments



Irish Demonstrator - Athlone



System Adaptation

Adapt and develop existing light gauge steel systems to modular circular panel

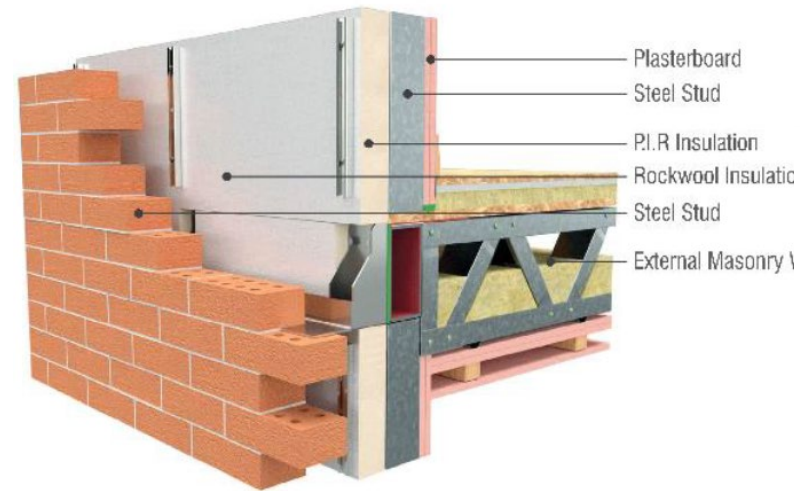

Vision Built

Data Survey Stages

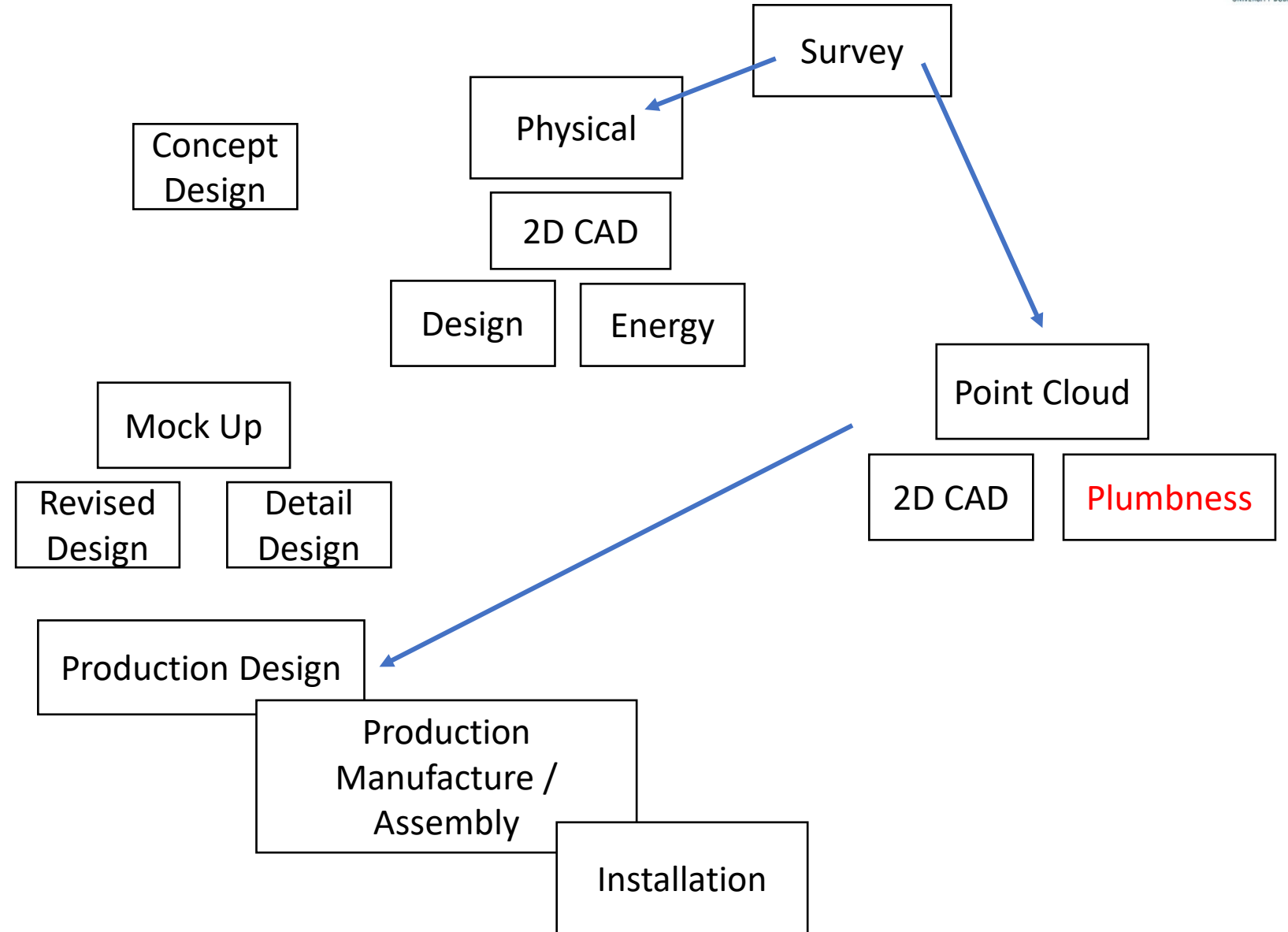

Design Concepts

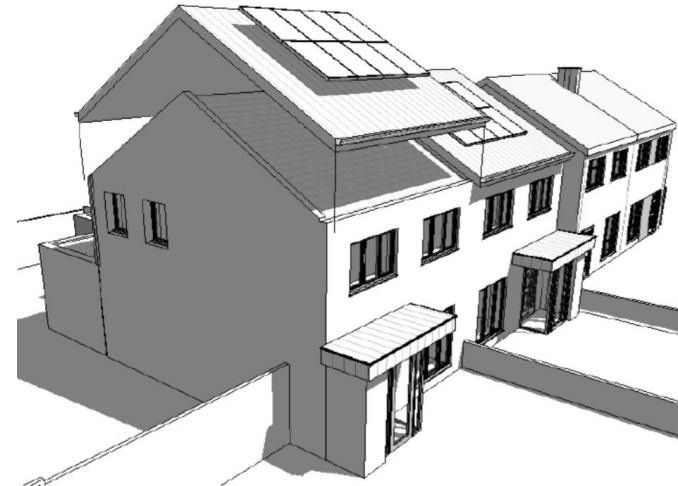
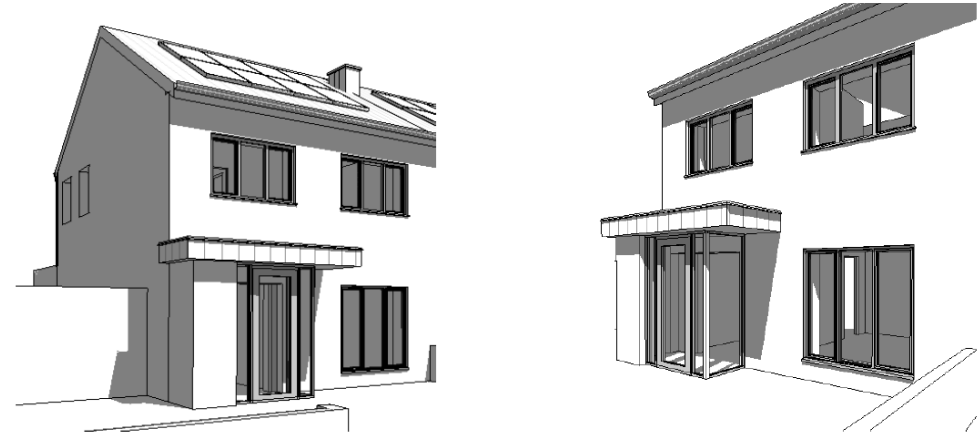

Coady Architects

Modular Panel Design Development

Initial design workshop

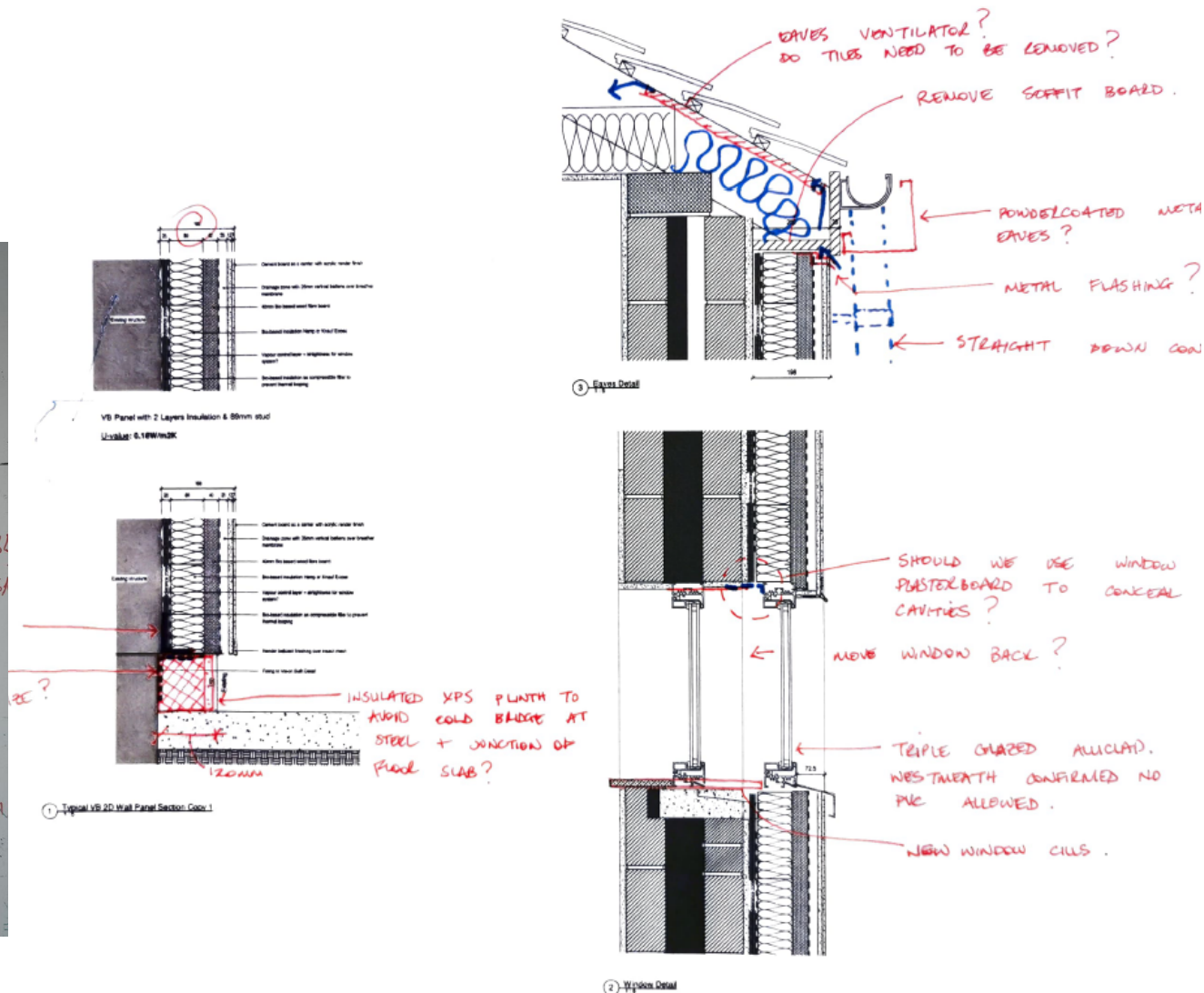
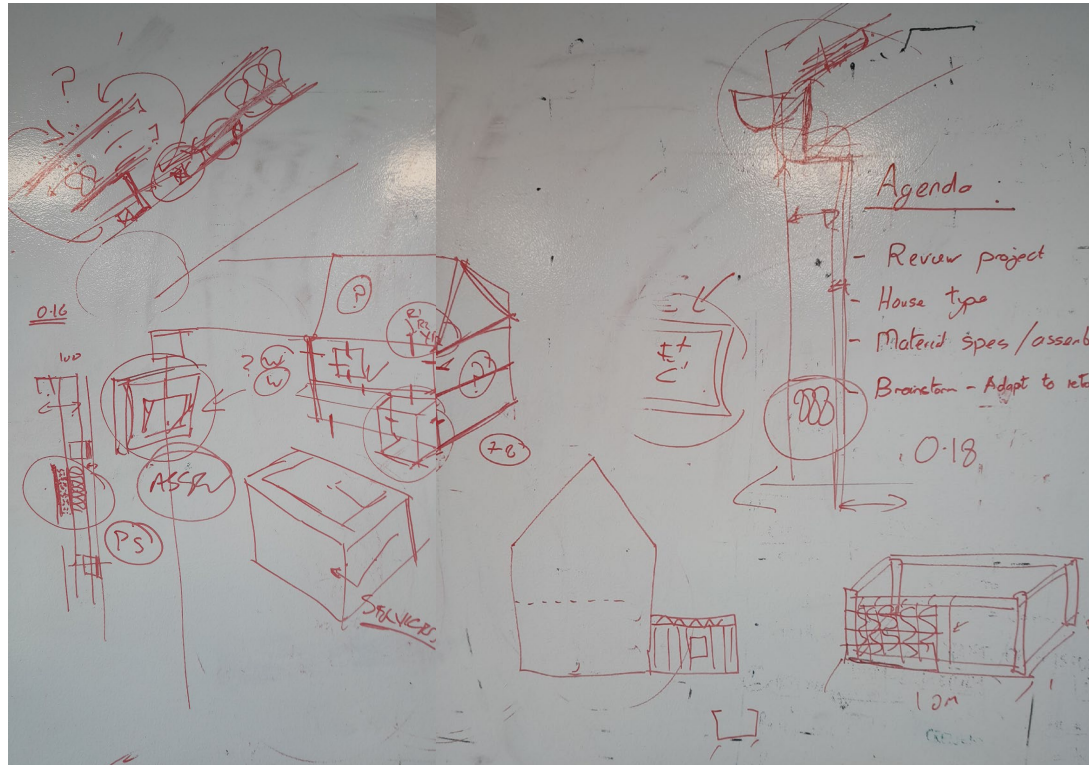

Modular Panel Design Development

Proposed Panel – Build Up

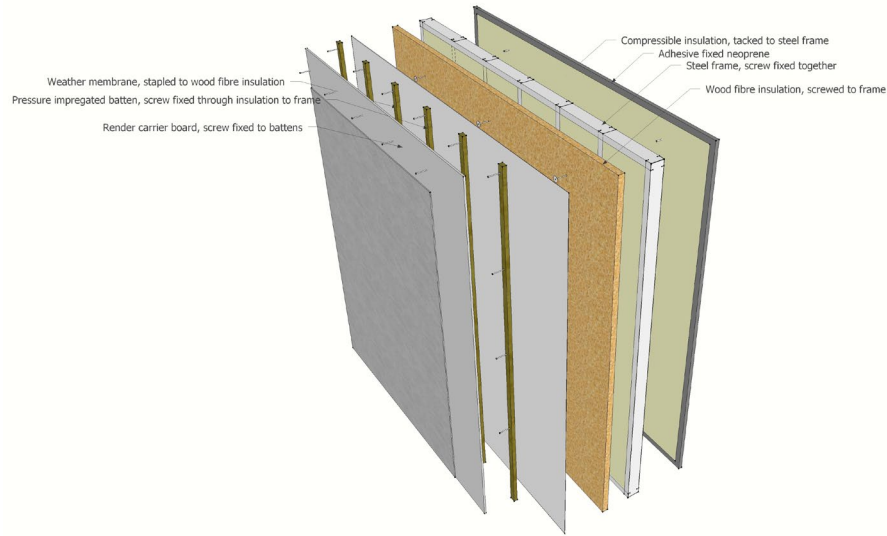

Coady Architects

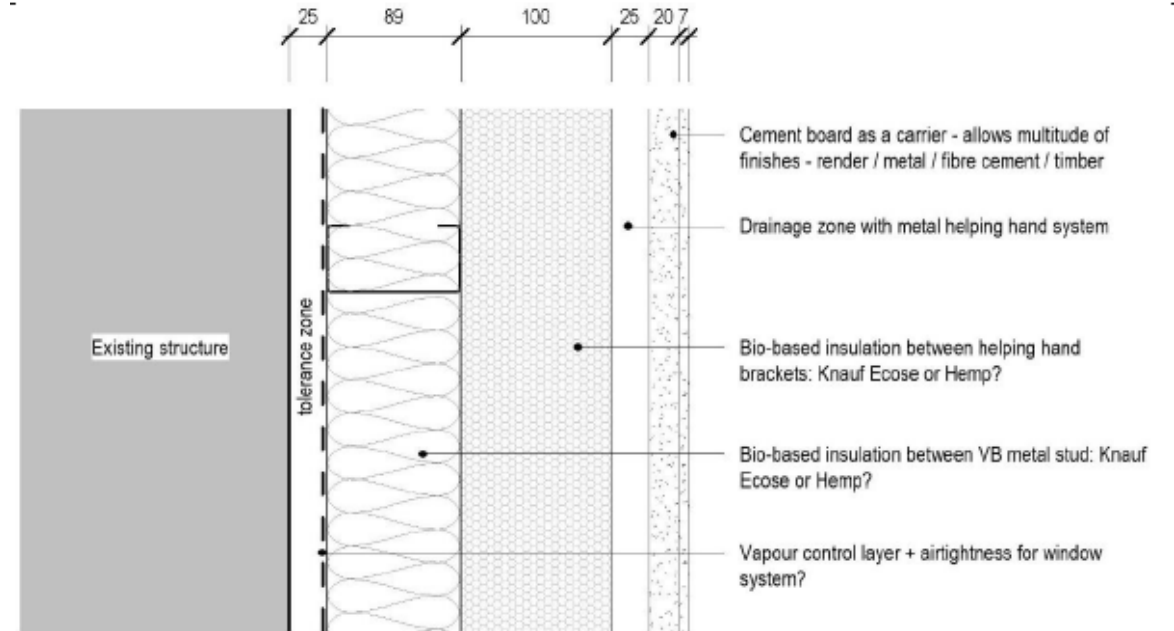

Survey 1

Physical Energy Characteristics Detail Design

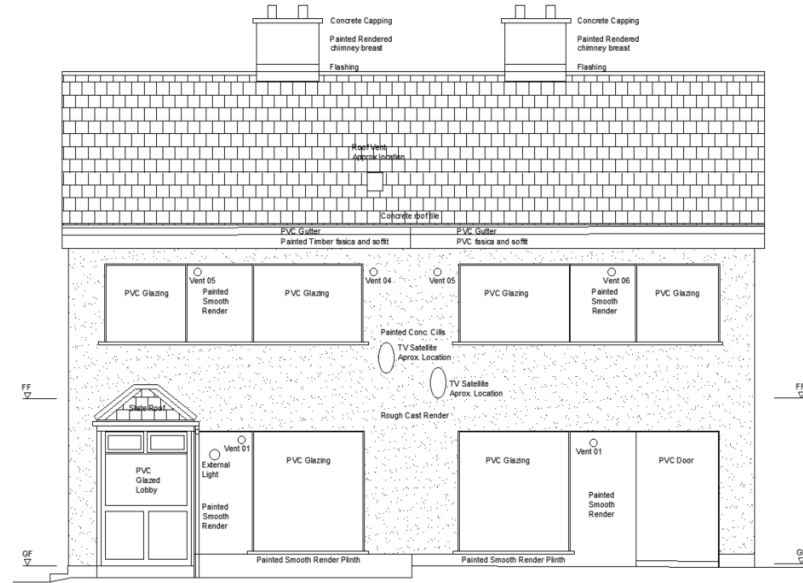

South (Front) Elevation

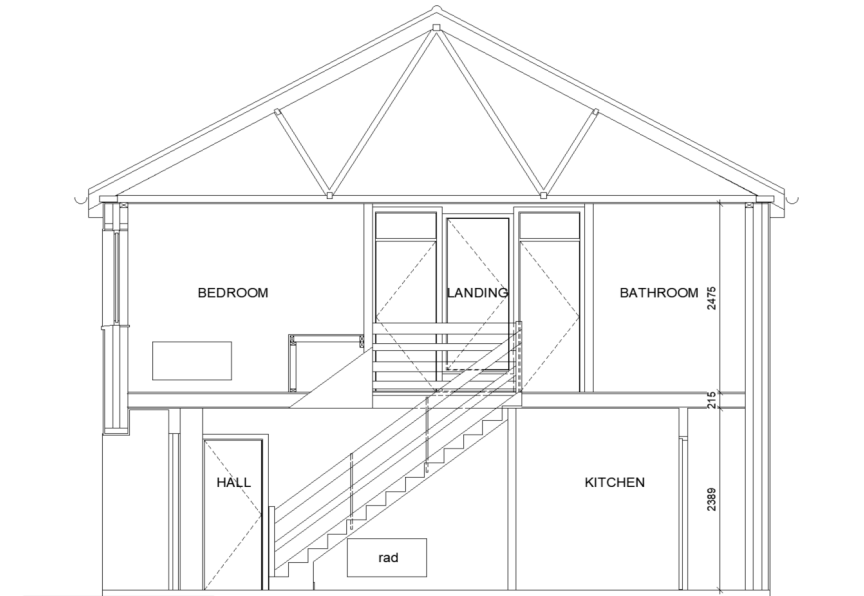
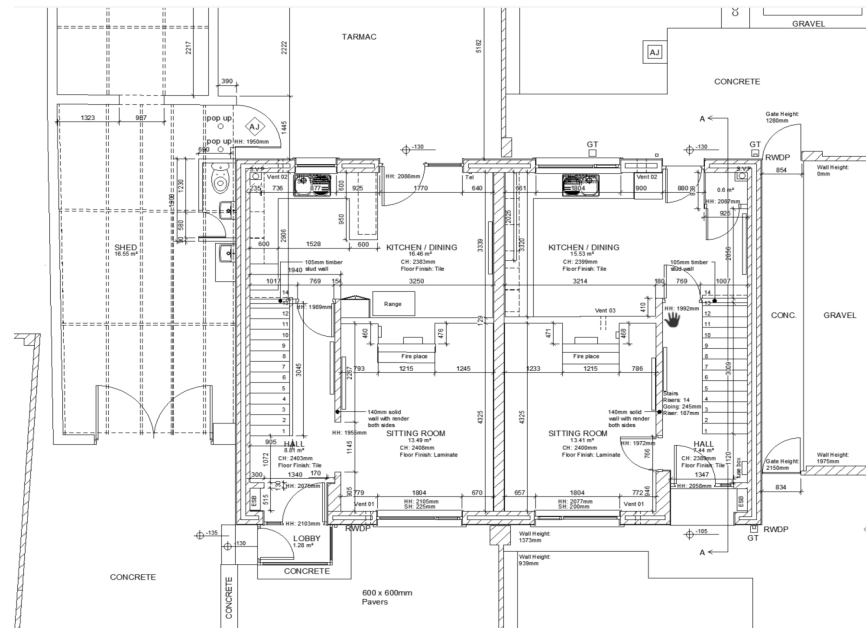

Section A

Irish Demonstrator

3 Bed Semi D

Built 1975

Masonry Cavity Wall

Cut Roof – Attic Vented

Original Range and Open Fire

Current No 7 HP

Current No 8 Range

Various stages of Upgrades
- WCC

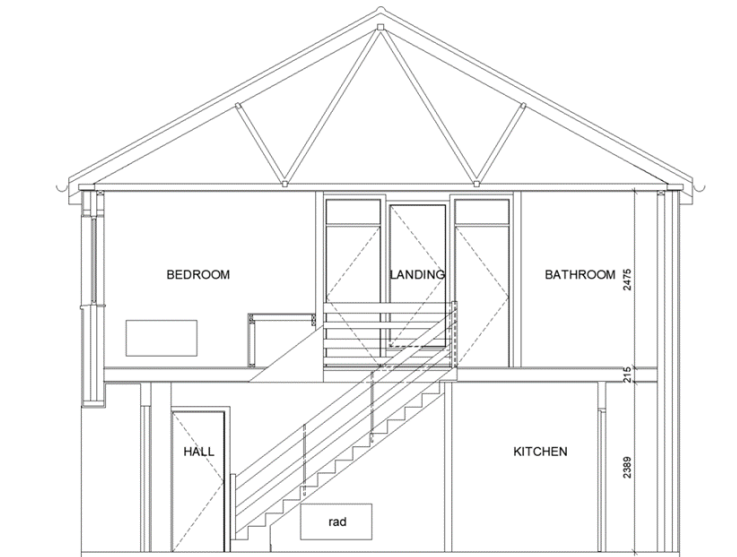

Section A

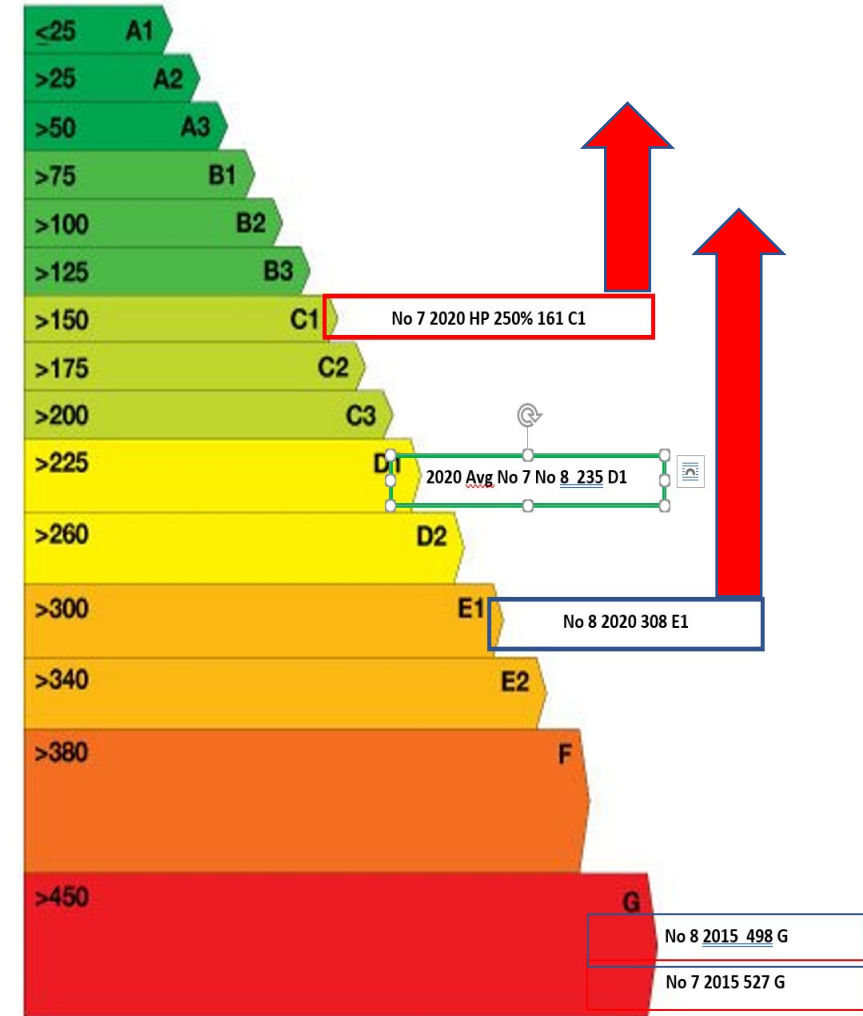

Design Concepts



Coady Architects

Critical Issues

TAR

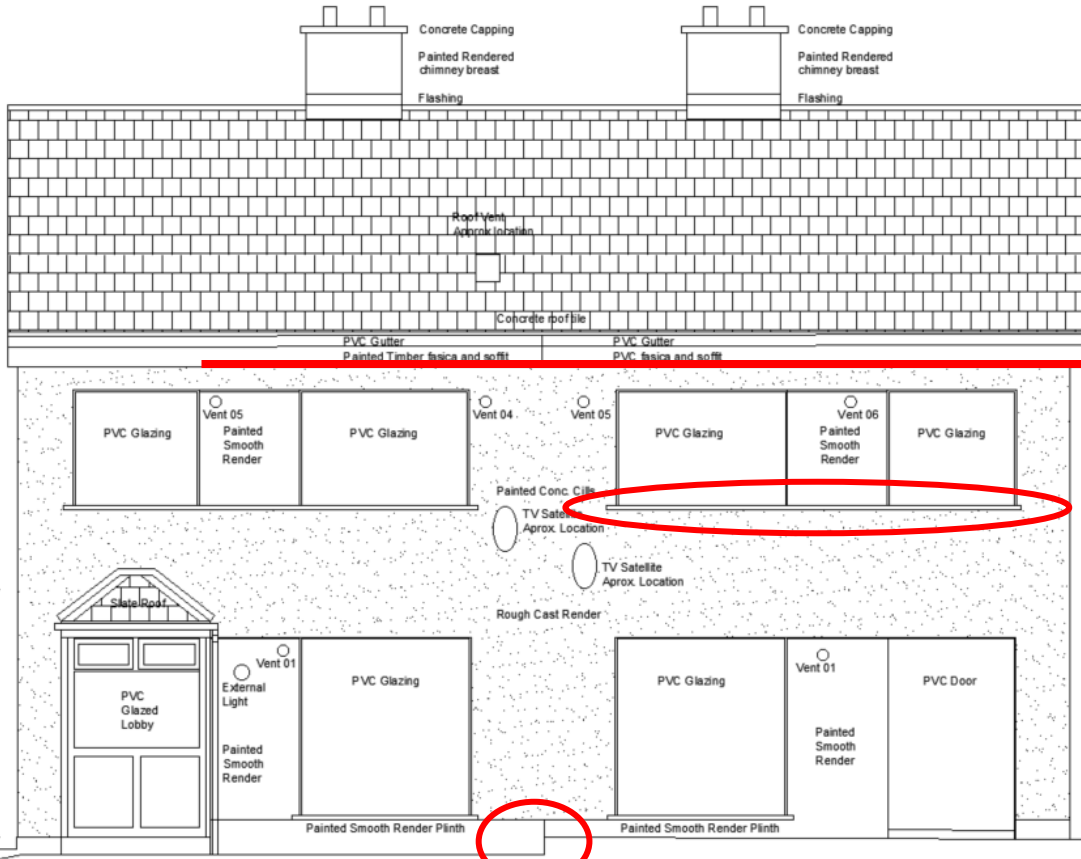

South (Front) Elevation

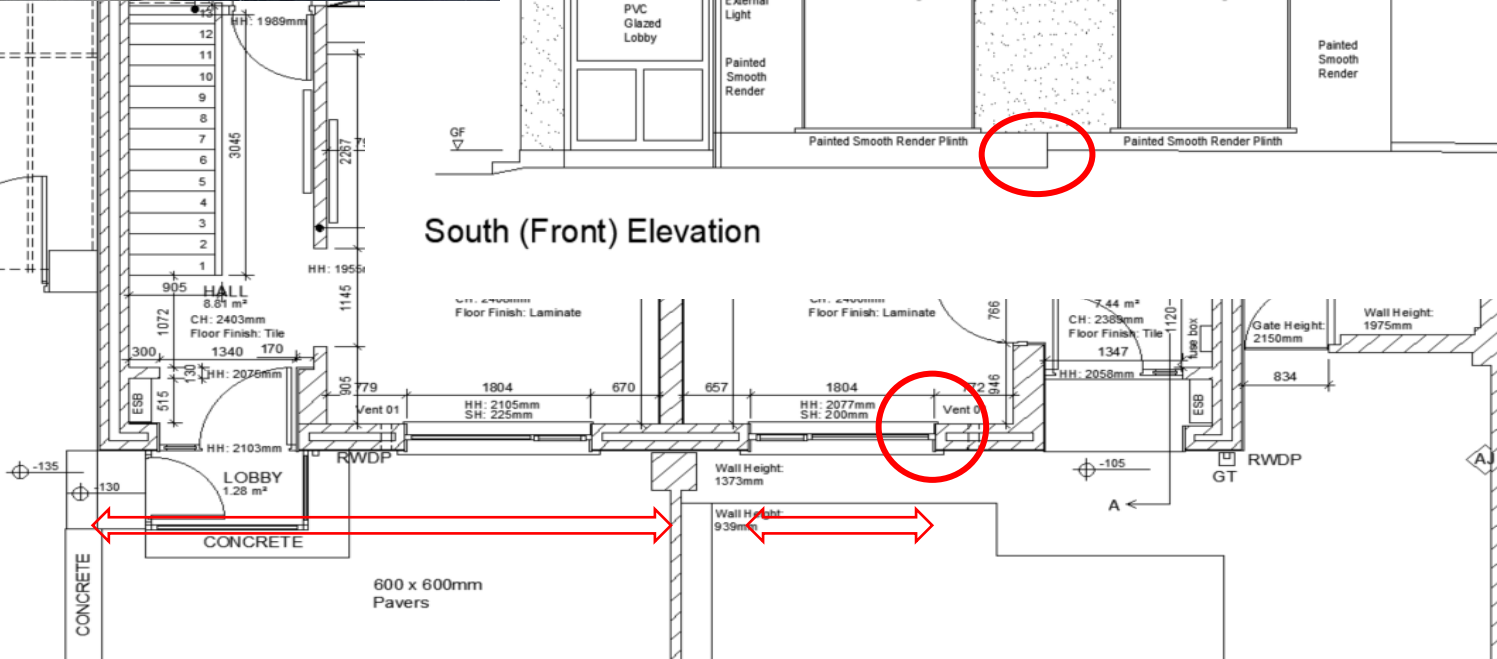

Section A

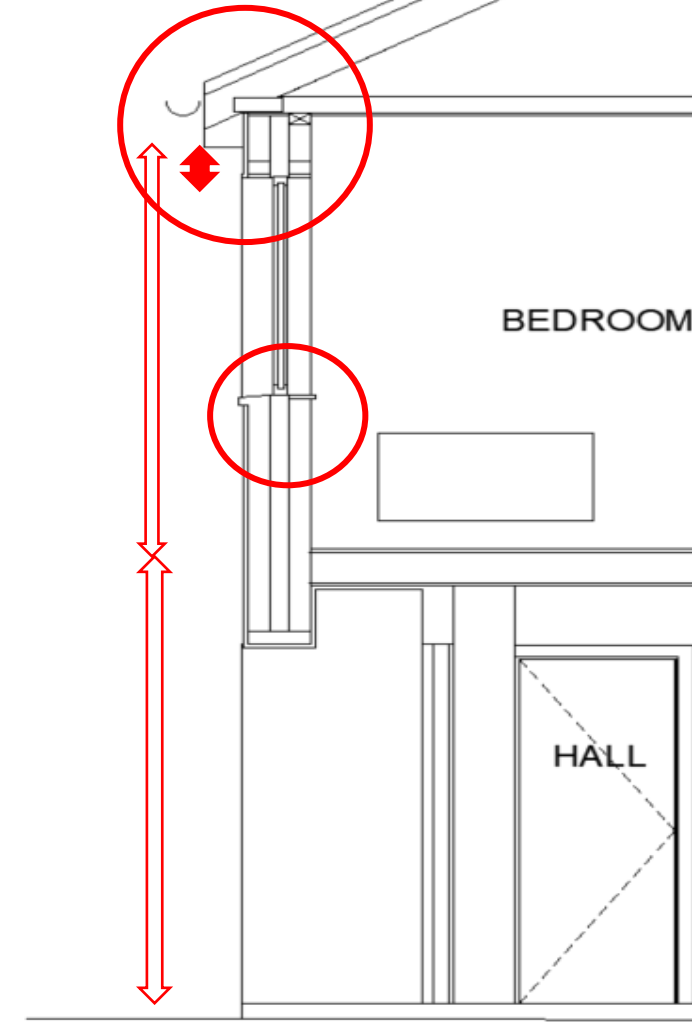

Developing a Circular Modular Construction System

Fabric Intervention to Walls

2D Modularised Wall Panel

To front elevation only

(Circularity)

3D Modularised Extension Pod

Air Lobby Porch

To front elevation only

(Circularity)

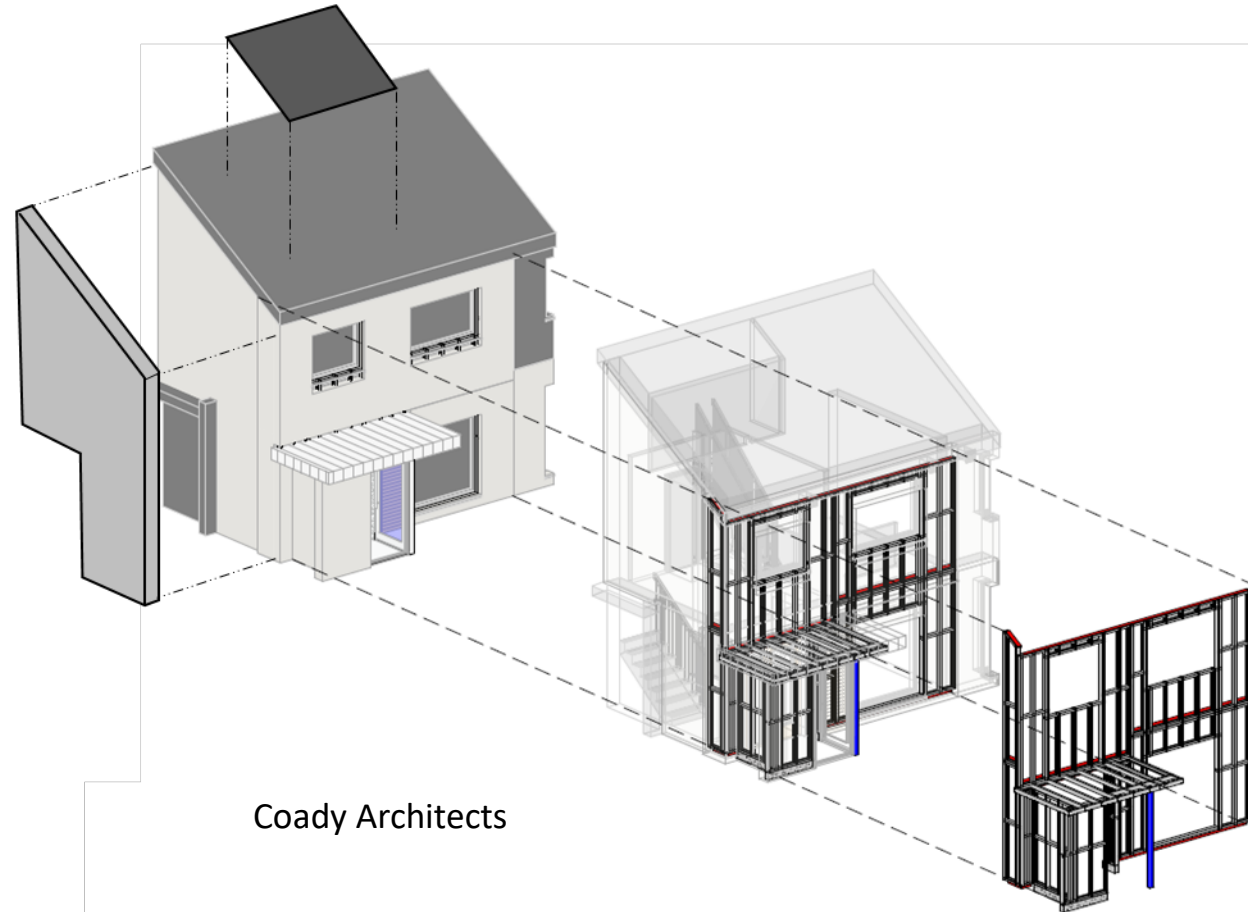

Coady Architects

Ongoing Circularity Assessment and Benchmarking

Irish Focus

DfD is core

DfD in Building Hierarchy

Level 1 Element

Level 2 Component

Level 3 Product Material

Biobased

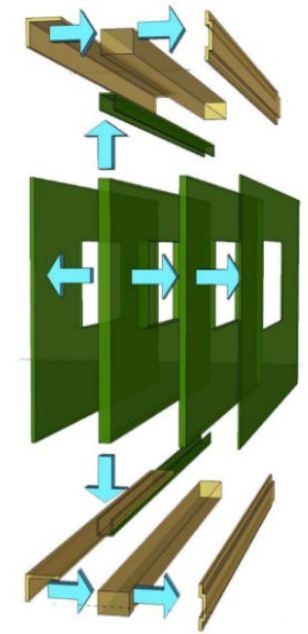
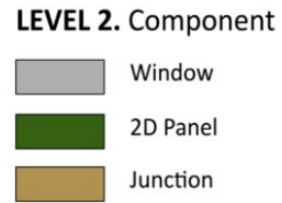
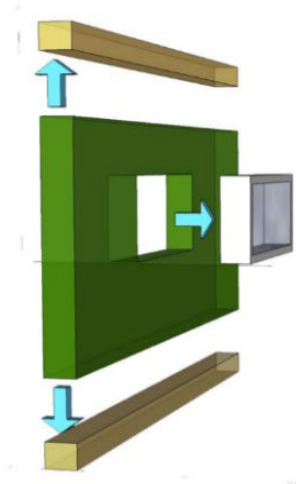
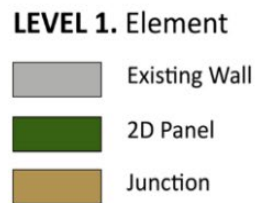
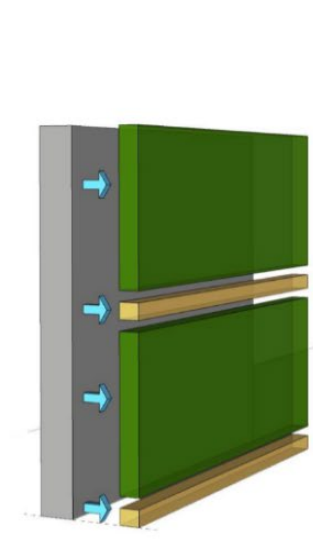

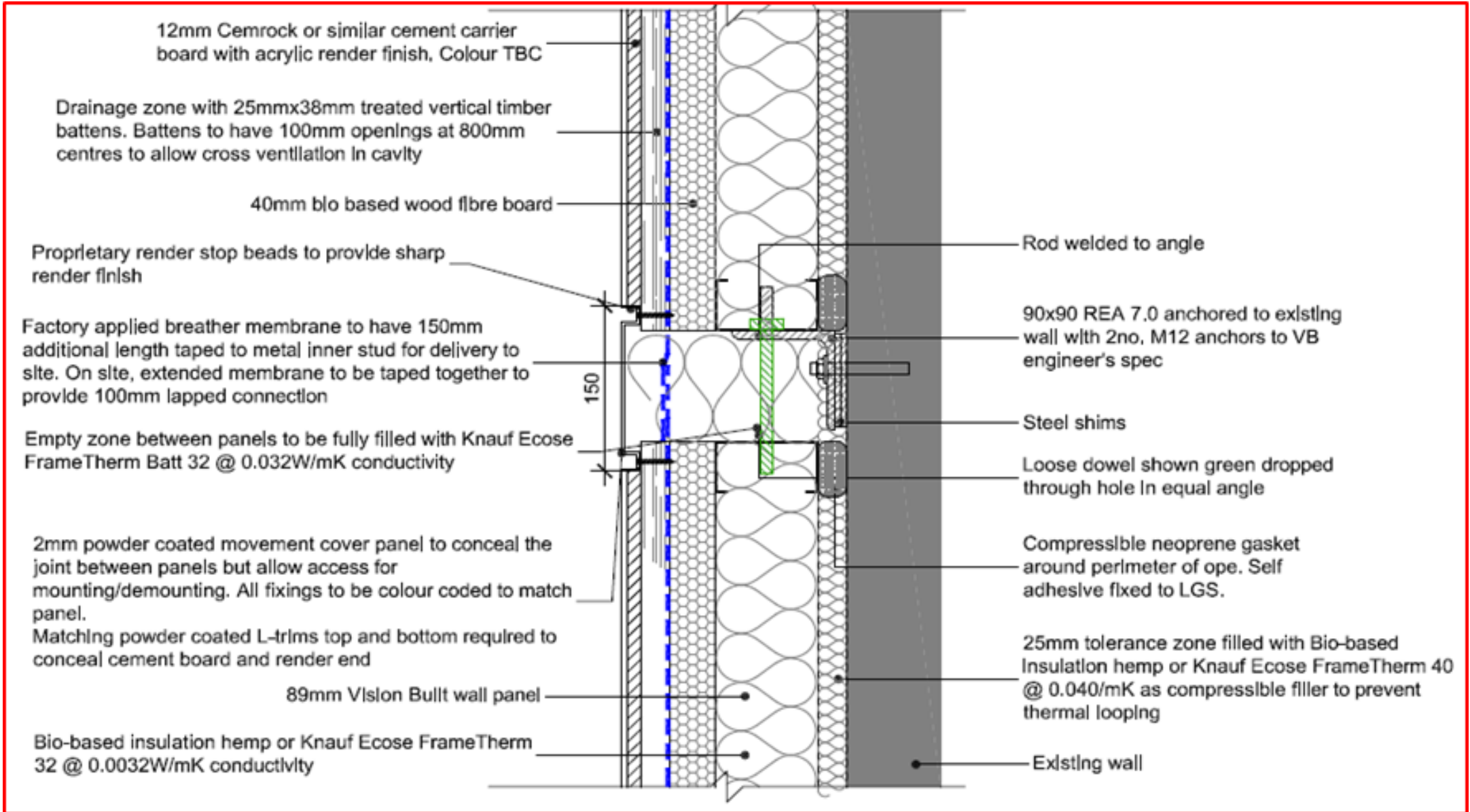

Mock Up

Testing

Manufacture
Installation
Buildability
Junctions
Weathering
Finishes
Quality
Aesthetics

Circularity – DfD

Full DfD Audit
Assembly – Install – deinstall -
disassembly – reassembly –
reinstall



Existing Wall in Tubbercurry, Sligo

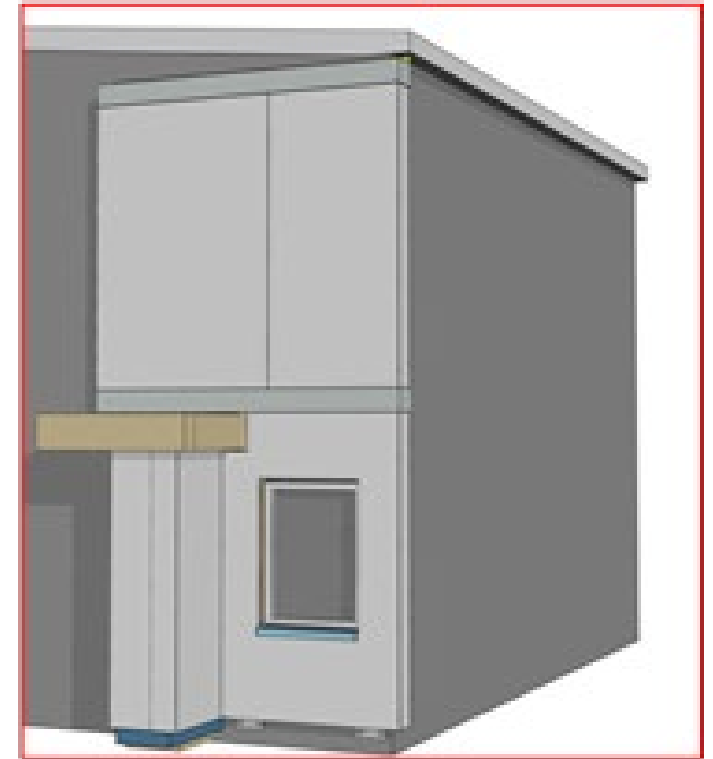

Proposed Test Panels on Existing Wall

Mock Up Design

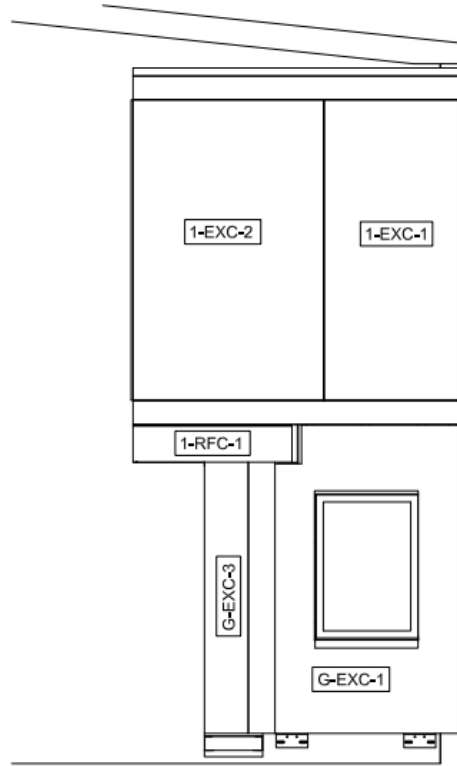

2 Front Elevation
SCALE: 1:20

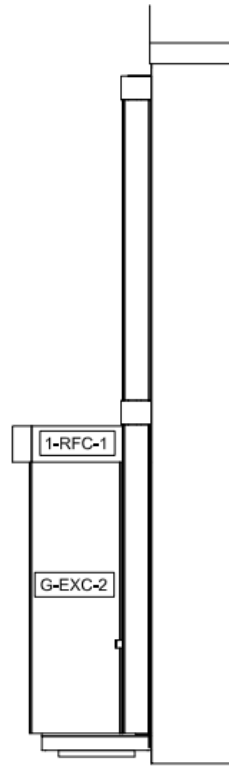

3 Side Elevation
SCALE: 1:20

Vision Built

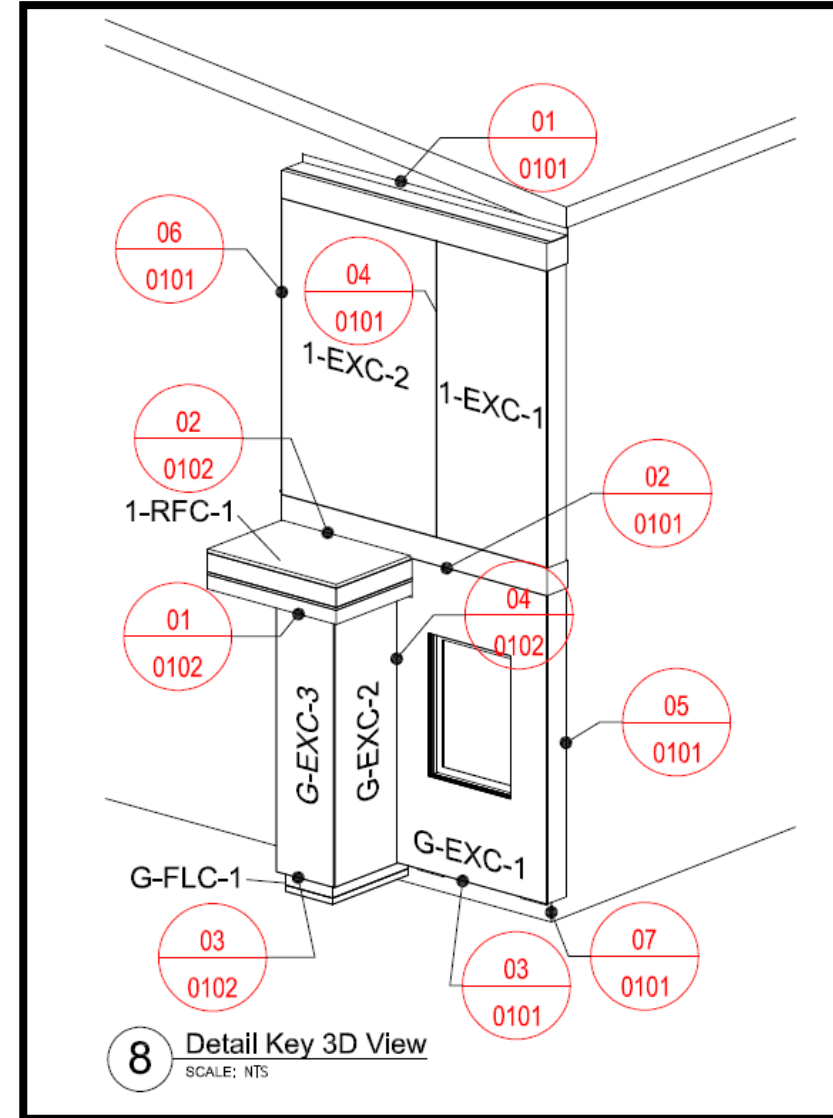

8 Detail Key 3D View
SCALE: NTS

Mock Up Design

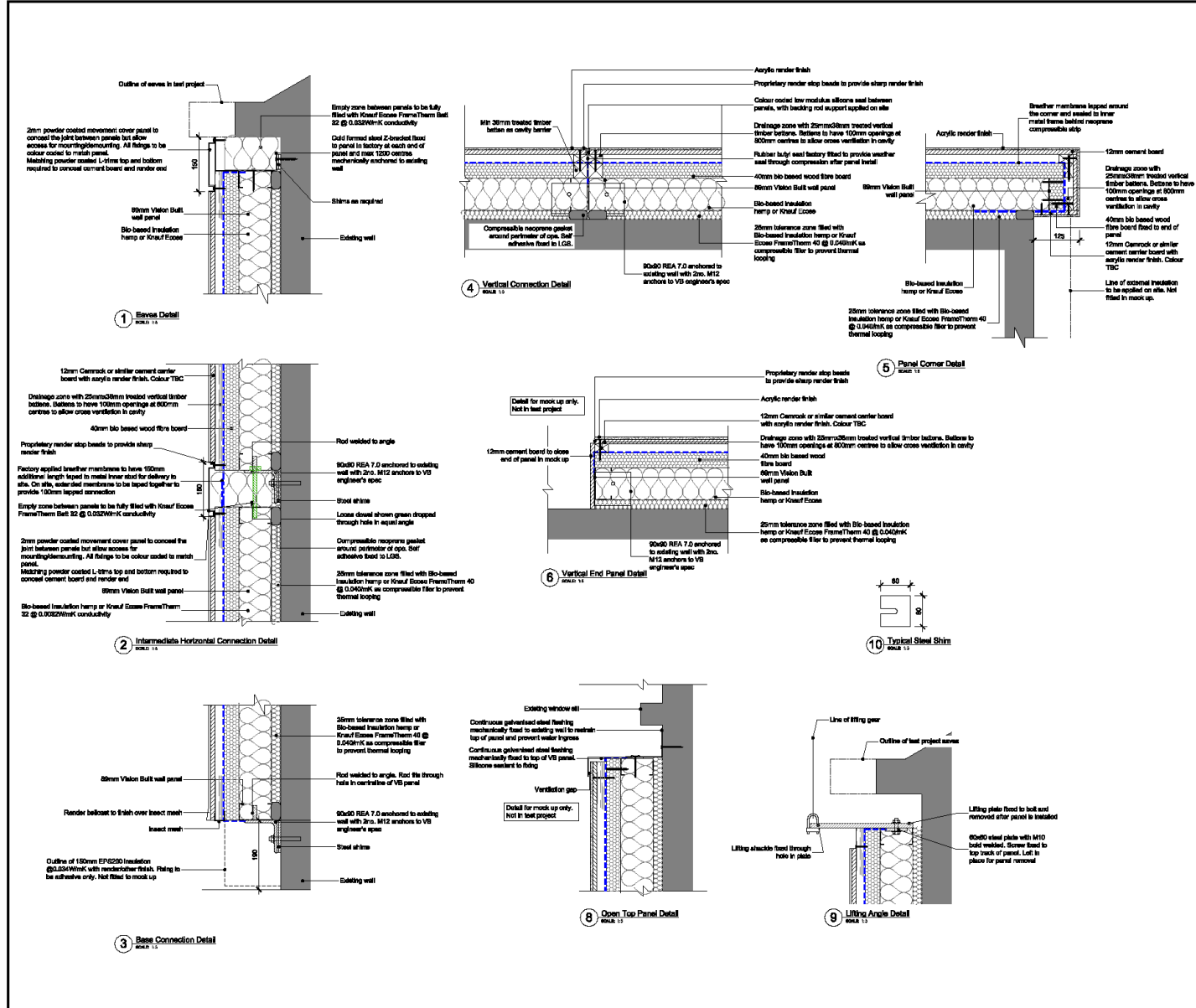

These drawings are the exclusive property of Vision-Built. Any Reproduction without Prior written authority is strictly prohibited. Do not scale drawings. Copyright © 2019

Note:
All materials by others shown indicatively.
Details to be agreed between architect and relevant sub-contractor/supplier in terms of arrangements & interfaces.

Client / Customer approval ensures this drawing meets their requirements for all specified dimensions:
1. Window opens.
2. Door opens.
3. Room heights.
4. Room dimensions.
5. Any other specified Dimensions.

DRAWING NOTES 1 DRAWING NOTES
DRAWING NOTES 2

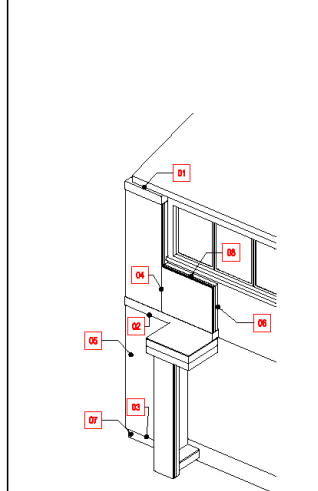

Rev.	Description	Date	Imp'd by
P01	Detail 2 updated. Detail 9 added	20.11.21	GW
P02	Updated to comments	22.11.21	GW
P03	Initial issue	21.11.21	GW
Rev.	Description	Date	Imp'd by
1	Unit 5, Deeppark Ind. Centre, Co. Dubuigh, Ireland		
VISIONBUILT BUILDING THE FUTURE. OFFSITE		info@vision-built.com	
Date:	21.10.21	Client:	Dive Zero
Scale:	1:5		
Appr:		Proj. Mgr:	Dive Zero
File:	DRW-01-VBS-X-ZZ-DR-X-0101	Rev:	P03 Original: A1

Mock Up A Install



Mock Up A Install



Mock Up A Lessons

General

Tolerance – more adjustment needed

Joints – not consistent

Finishes – render ? Complex in manufacture, some chips and marks

Horizontal Joint – poor visually – possible water ingress ?

Backing insulation and neoprene seal – not working

DfD Audit

Window connection poor

DfD at All Levels

Most materials salvaged and re used

Fixings – Too many, damaged

Full – reassembly

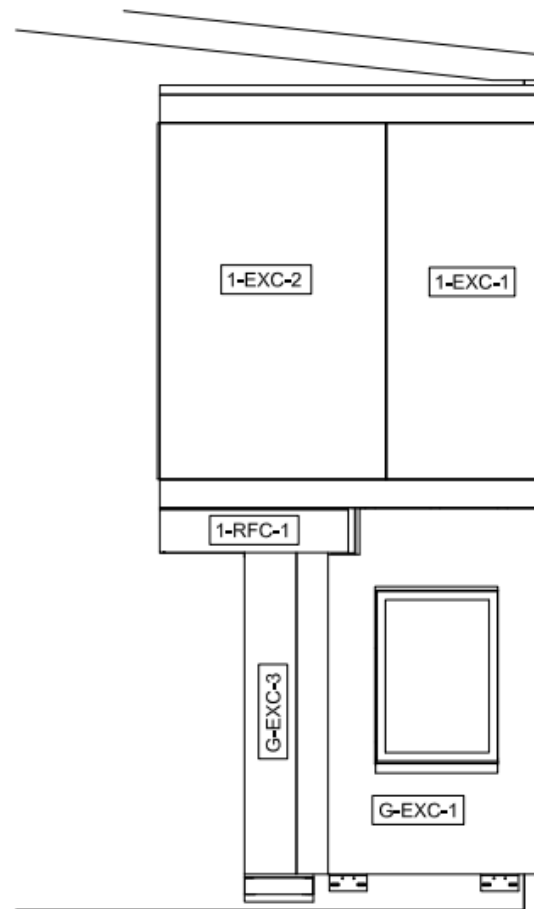

② Front Elevation
SCALE: 1:20

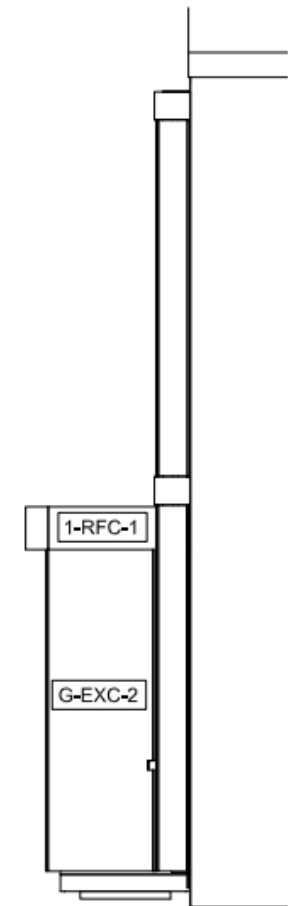

③ Side Elevation
SCALE: 1:20

Survey 2 3D Point Cloud



Survey 3D Point Cloud

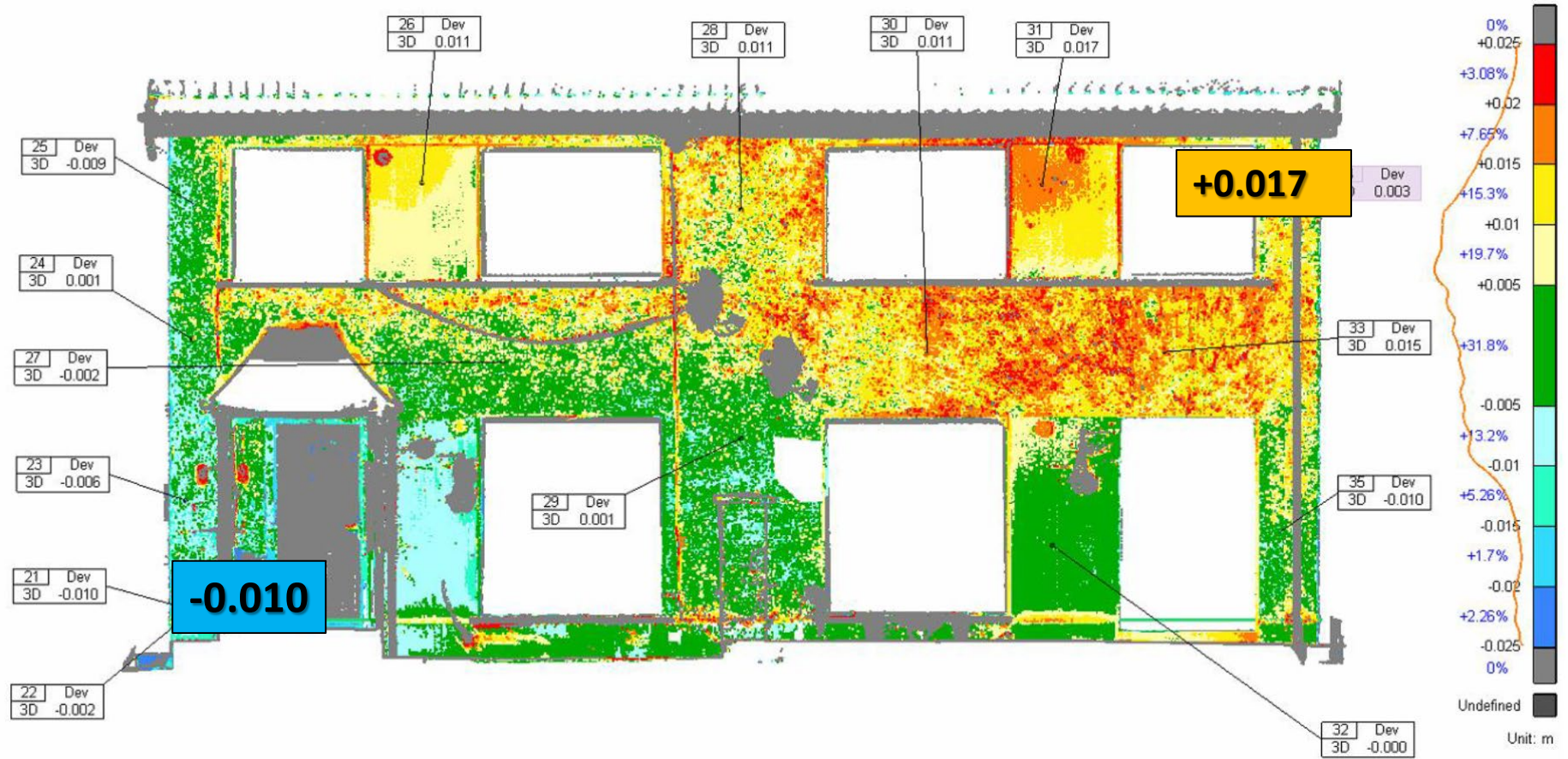

Survey 3D Point Cloud

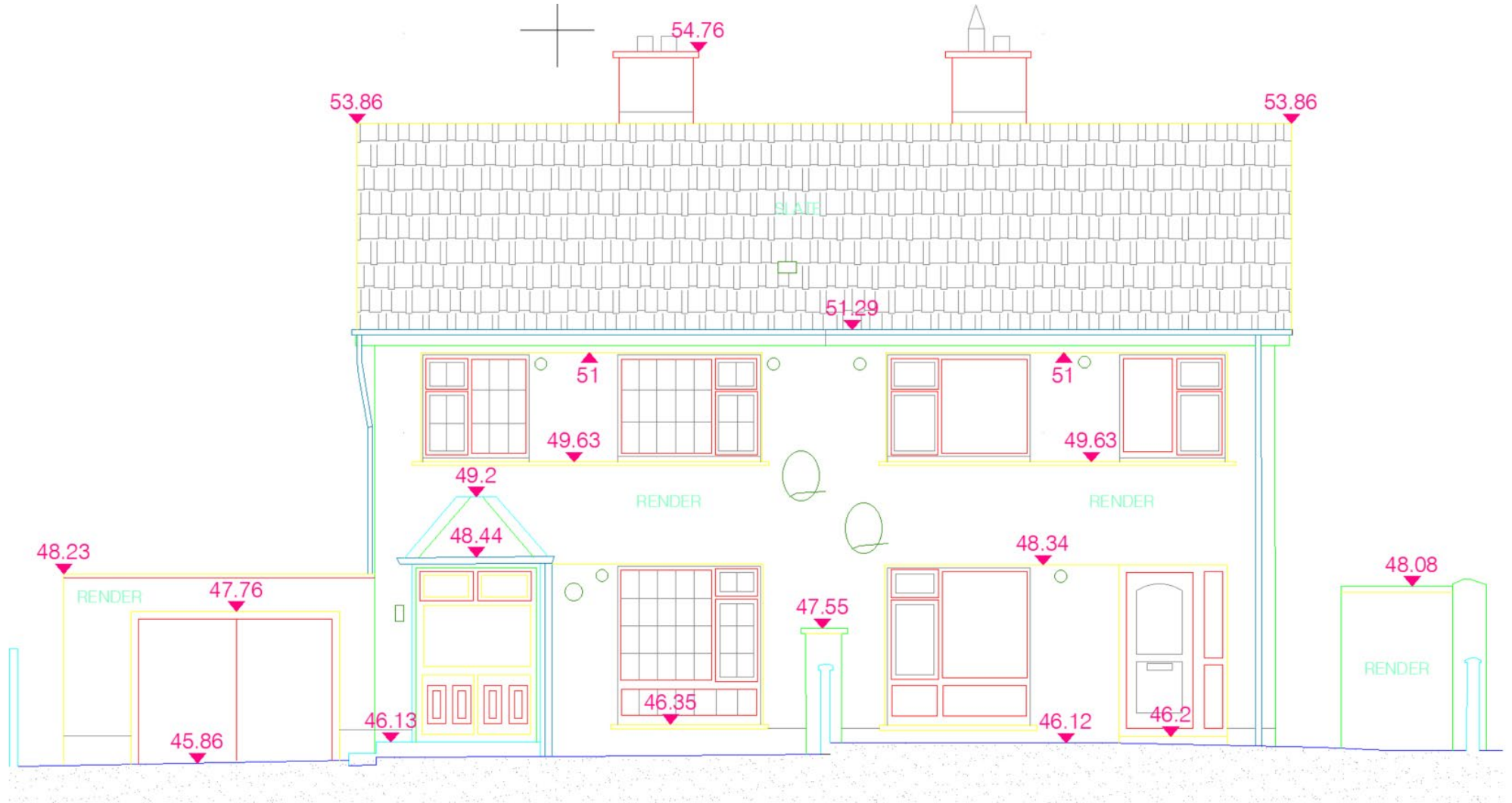

Survey 3D Point Cloud

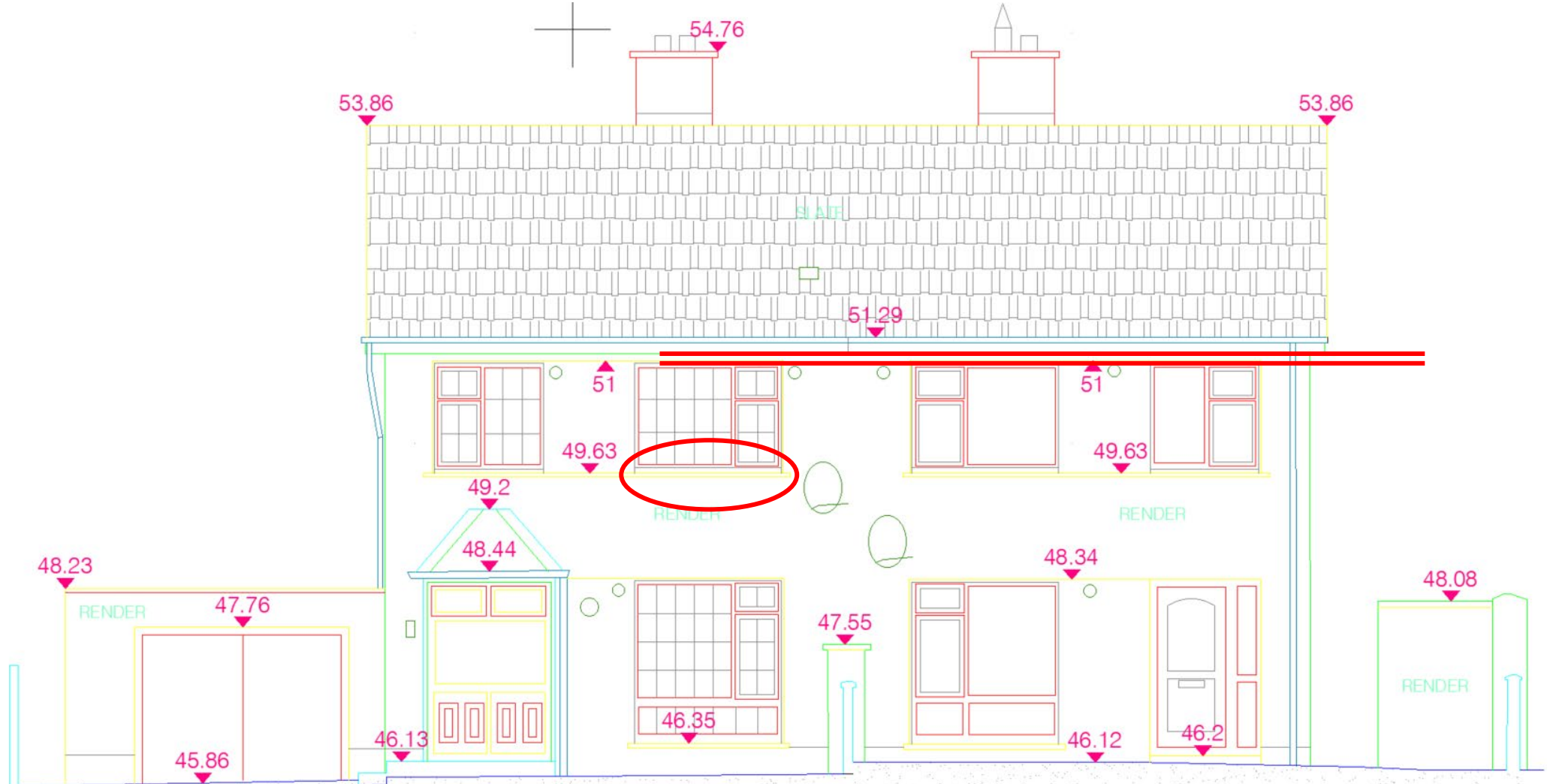

Mock Up B Revised Panel Install

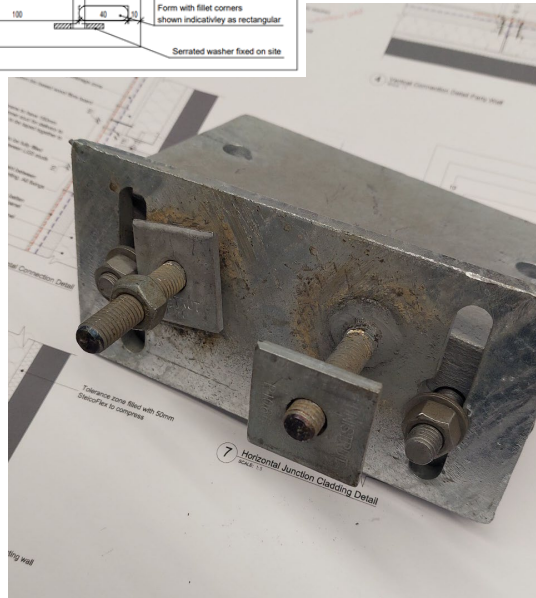
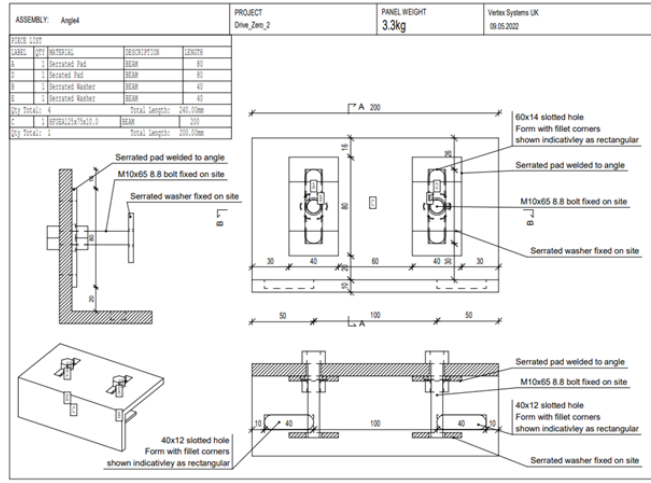

Mock Up B Lessons

General

Dry finish – preferable

Manufacture – technical lessons working with board

Open jointing ?? - review – proposed drips

Backing insulation

Roof detail and finishes – revised.

EAVES PROJECTION

DfD

DfD at All Levels in Hierarchy

Full disassembly– reassembly, (alternative finishes)

– re-installed.

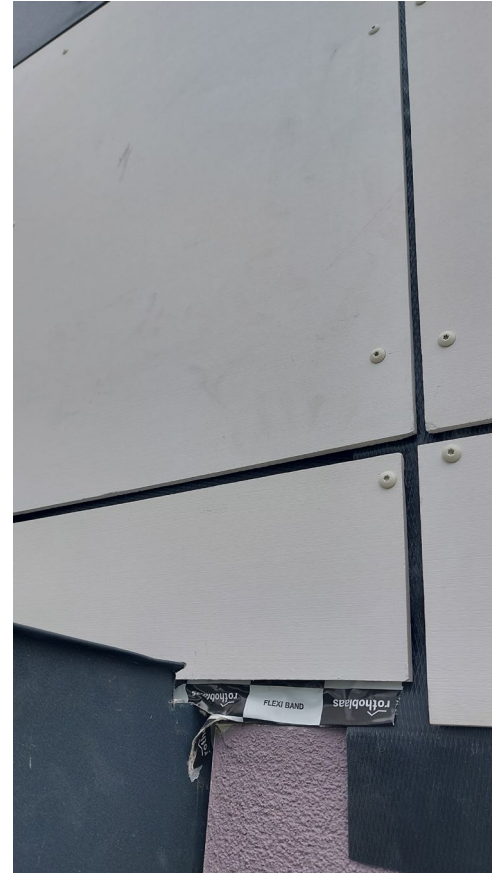

Mock Up C Full Panel Install – Eaves



Vision Built



Detail Design and Production

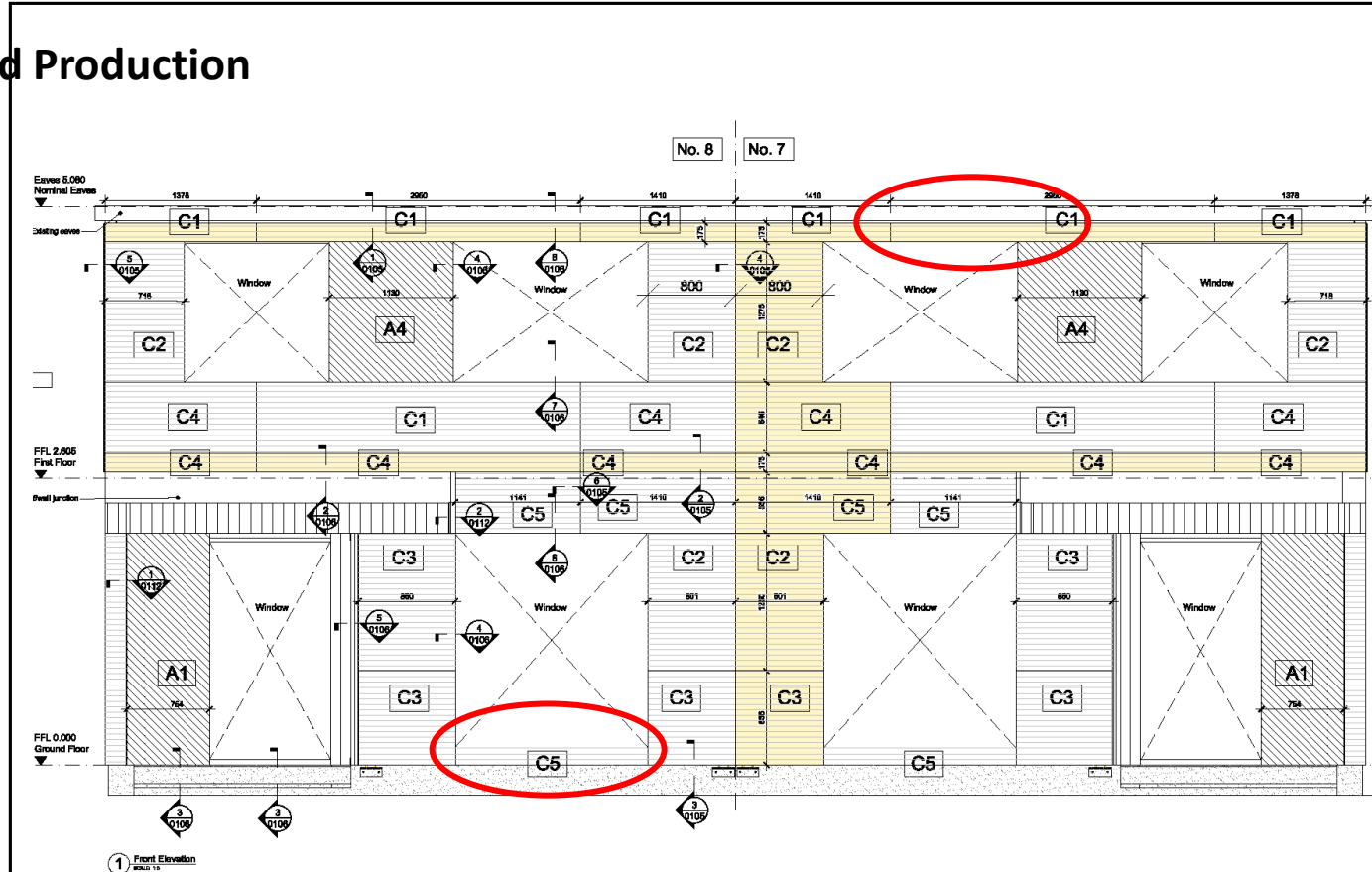





These drawings are the exclusive property of Vision-Built. Any Reproduction without Prior written authority is strictly prohibited. Do not scale drawings. Copyright © 2019

Note:
All materials by others shown indicatively.
Details to be agreed between architect and relevant sub-contractor/supplier in terms of arrangements & interfaces.

Client / Customer approval ensures this drawing meets their requirements for all specified dimensions:
1. Window sizes.
2. Door sizes.
3. Room heights.
4. Room dimensions.
5. Any other specified Dimensions.

• DRAWING NOTES 1 DRAWING NOTES
• DRAWING NOTES 2

-  Cambrit P-222 with horizontal grain
-  Cambrit P-270 with vertical grain
-  Rendered external wall insulation by others
-  Aluminium standing seam facade SEAL 7018
-  Panels measured, cut and fitted on site

NOTE:
Cladding dimensions are notional for ordering material only.
Construction dimensions vary between rouses

Rev.	Description	Date	Impl. by
P07	No. 7 checking beside porch updated	22.08.22	GW
P02	Updated to comments	28.08.22	GW
P01	Initial Issues	16.08.22	GW
		Unit 5, Deerpark Ind. Cremorne, Co. Dub., Ireland info@vision-built.com	
Date:	Project:	Drawn:	Scale:
16.08.22	Drive Zero	GW	1:5
Client:	Client:	Client:	Client:
16.08.22	Drive Zero	16.08.22	16.08.22
Appr.	Subj. Status Code	14 - Model for Review and Comment	
16.08.22			
File:	DRV-VBS-X-ZZ-DR-X-010	Rev.:	P03 Orig. Size: A1

Detail Design and Production

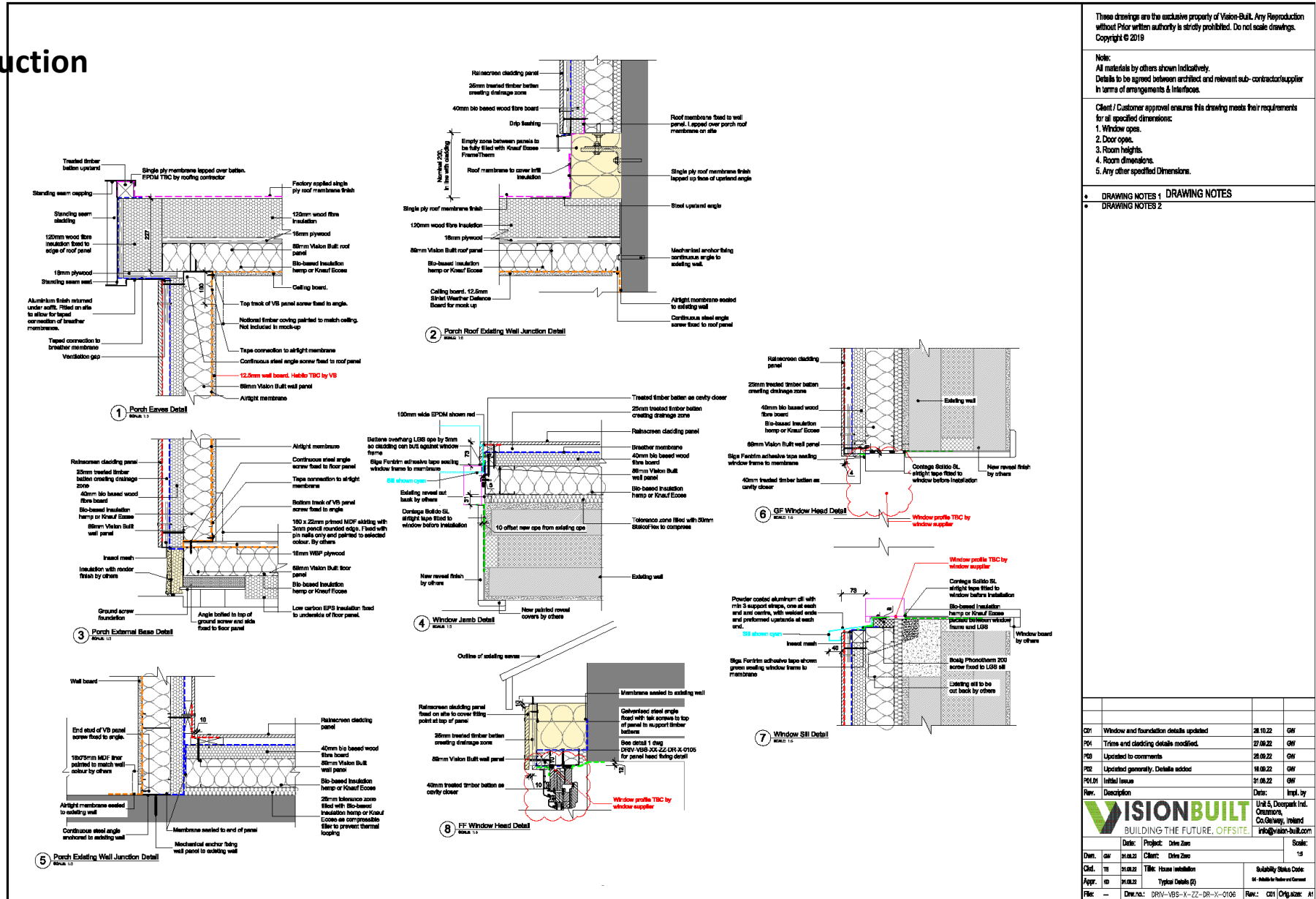

1 Porch Eaves Detail
SCALE: 1:5

2 Porch Roof External Wall Junction Detail
SCALE: 1:5

3 Porch External Base Detail
SCALE: 1:5

4 Window Jamb Detail
SCALE: 1:5

5 Porch External Wall Junction Detail
SCALE: 1:5

6 GF Window Head Detail
SCALE: 1:5

7 Window SHI Detail
SCALE: 1:5

8 FF Window Head Detail
SCALE: 1:5

Notes:

- These drawings are the exclusive property of Vision-Built. Any reproduction without prior written authority is strictly prohibited. Do not scale drawings. Copyright © 2019
- Note: All materials by others shown indicatively. Details to be agreed between architect and relevant sub-contractor/supplier in terms of arrangements & interfaces.
- Client / Customer approval ensures this drawing meets their requirements for all specified dimensions:
 - Window opens.
 - Door opens.
 - Room heights.
 - Room dimensions.
 - Any other specified Dimensions.

DRAWING NOTES 1 DRAWING NOTES

DRAWING NOTES 2

Revision Table:

Rev.	Description	Date	Drawn by
PKM	Initial Issue	31.08.22	GW
PKM	Updated generally, Details added	18.09.22	GW
PKM	Updated to comments	28.09.22	GW
PKM	Trims and cladding details modified.	27.09.22	GW
PKM	Window and foundation details updated	28.10.22	GW

Project Information:

Client:	Drive Zone	Project:	Drive Zone	Date:	18.09.22	Scale:	1:5
Arch:	House Installation	Drawn by:	GW	Checked by:	GW	Submittal Status Code:	SI - Details for Review or Comment
Appr. by:	Typical Details (P)	Drawn by:	GW	Checked by:	GW	Rev.:	001
File:	DRY-VS-X-ZZ-DR-X-0106	Drawn by:	GW	Checked by:	GW	Original size:	A1

Detail Design and Production

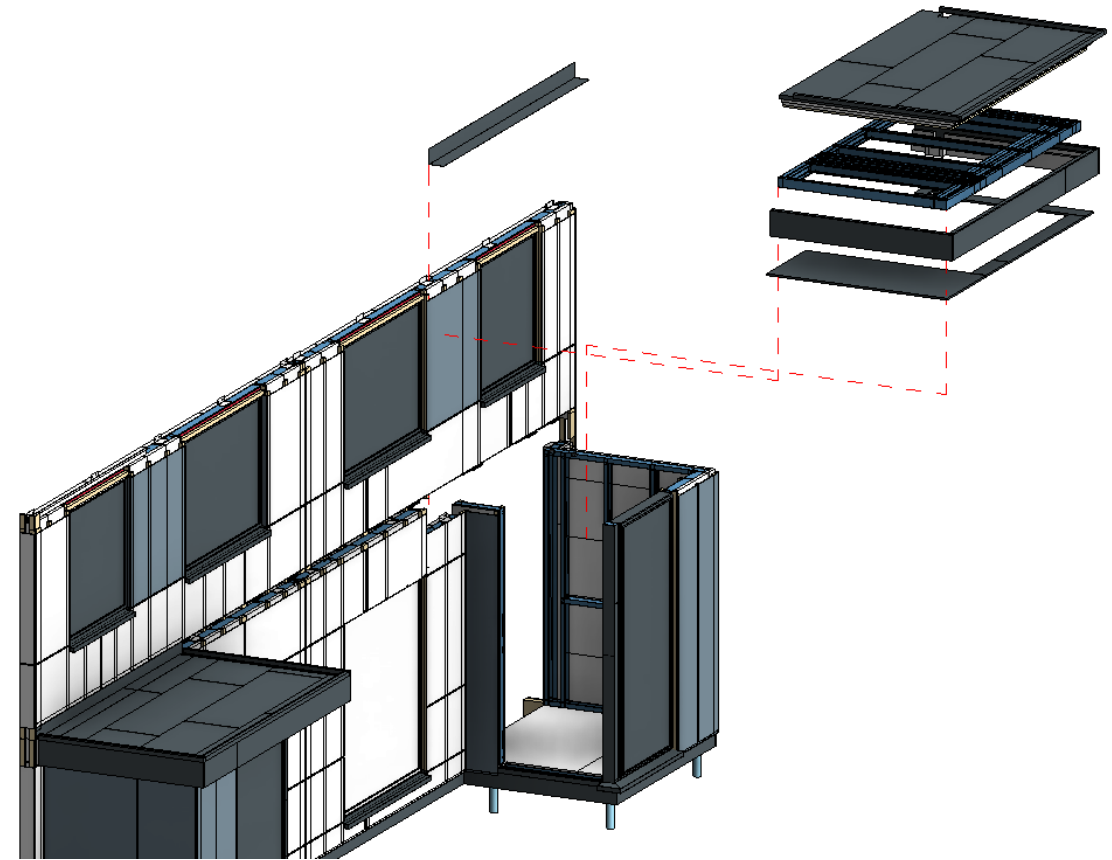
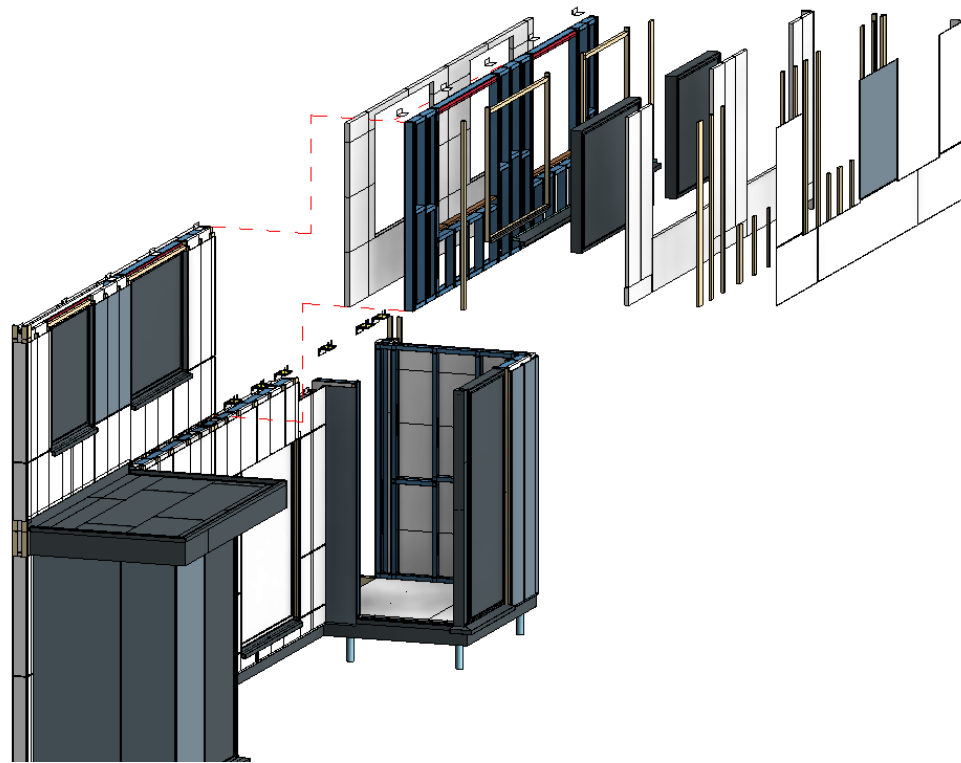

Vision Built

Production

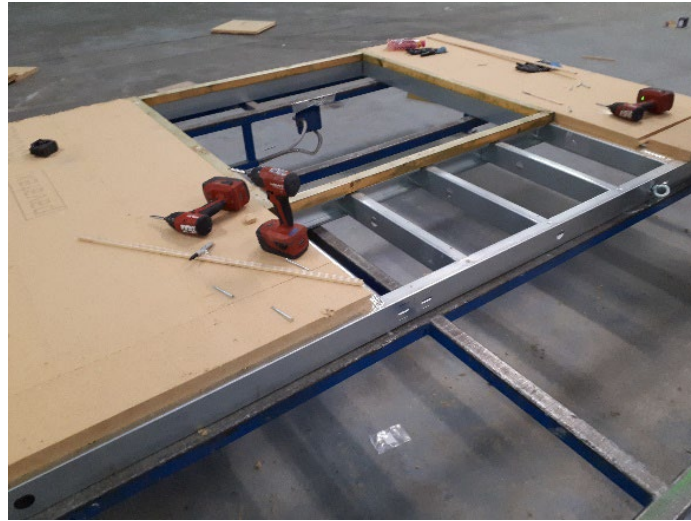

Vision Built

Transport



Vision Built

Retrofit Site Works

Enabling and EWI

Ground works

Windows remove and install

EWI - sides and rear

Preparation for Modular Panels



Retrofit Site Works

Modular System 2D

Brackets

Ground Screws

SETTING OUT

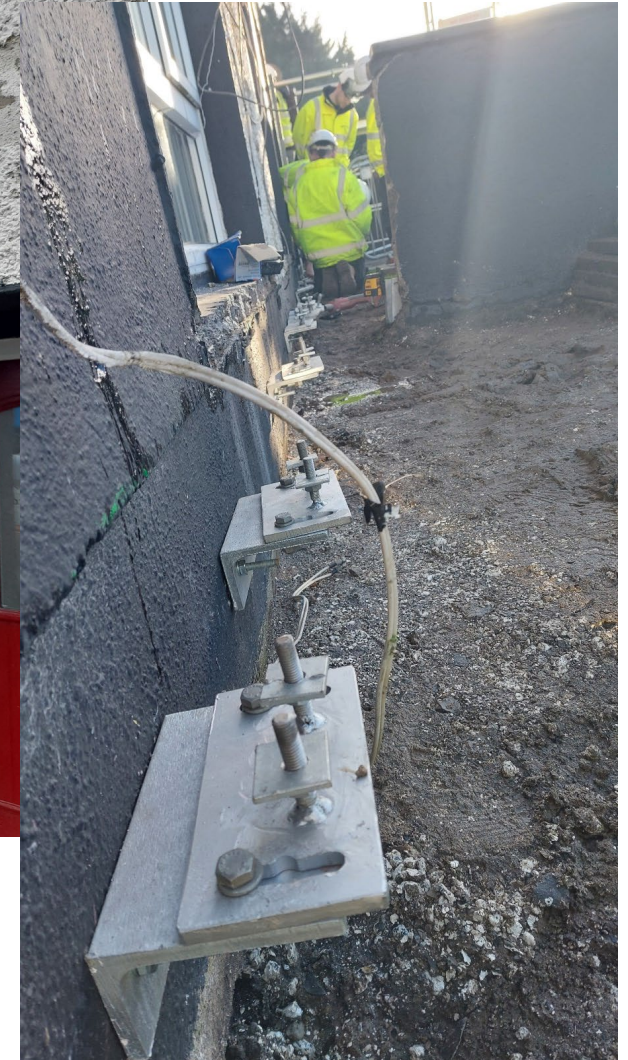

Retrofit Site Works

Modular System 2D

Installation



Retrofit Site Works

Modular System 2D

Installation



Retrofit Site Works

Modular System 2D

Installation



Retrofit Site Works

Modular System 2D

Installation



Retrofit Site Works

Modular System 2D

Installation



Retrofit Site Works

Modular System 2D 3D

Eaves



Retrofit Site Works

Modular System 2D 3D

Window removal



Retrofit Site Works

Modular System 2D 3D

Installation



Retrofit Site Works

Modular System 2D 3D

Installation



Retrofit Site Works

Modular System 2D 3D

Installation



Retrofit Site Works

Modular System 2D 3D

Near Completion



Data Survey Stages

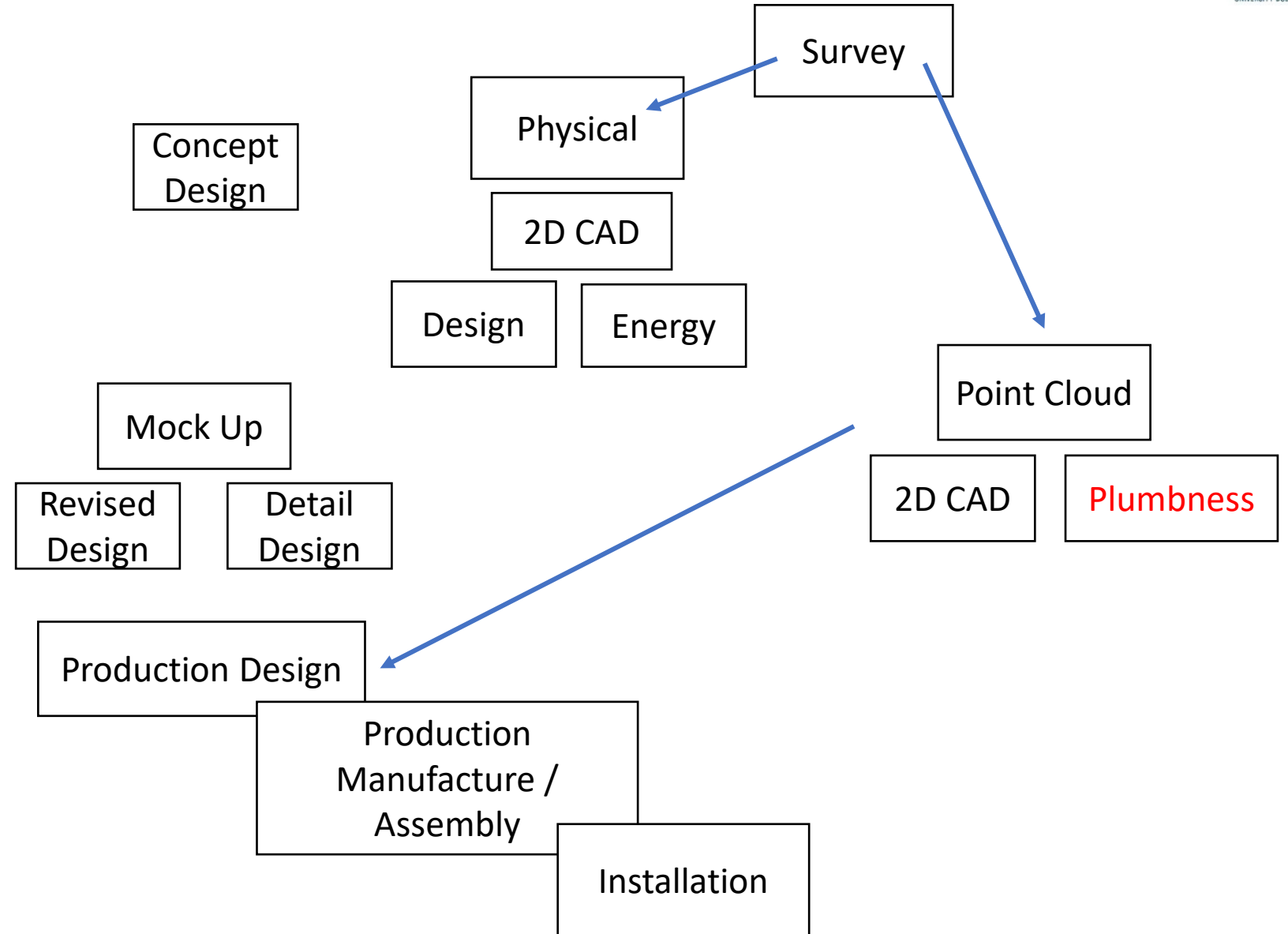

Issues

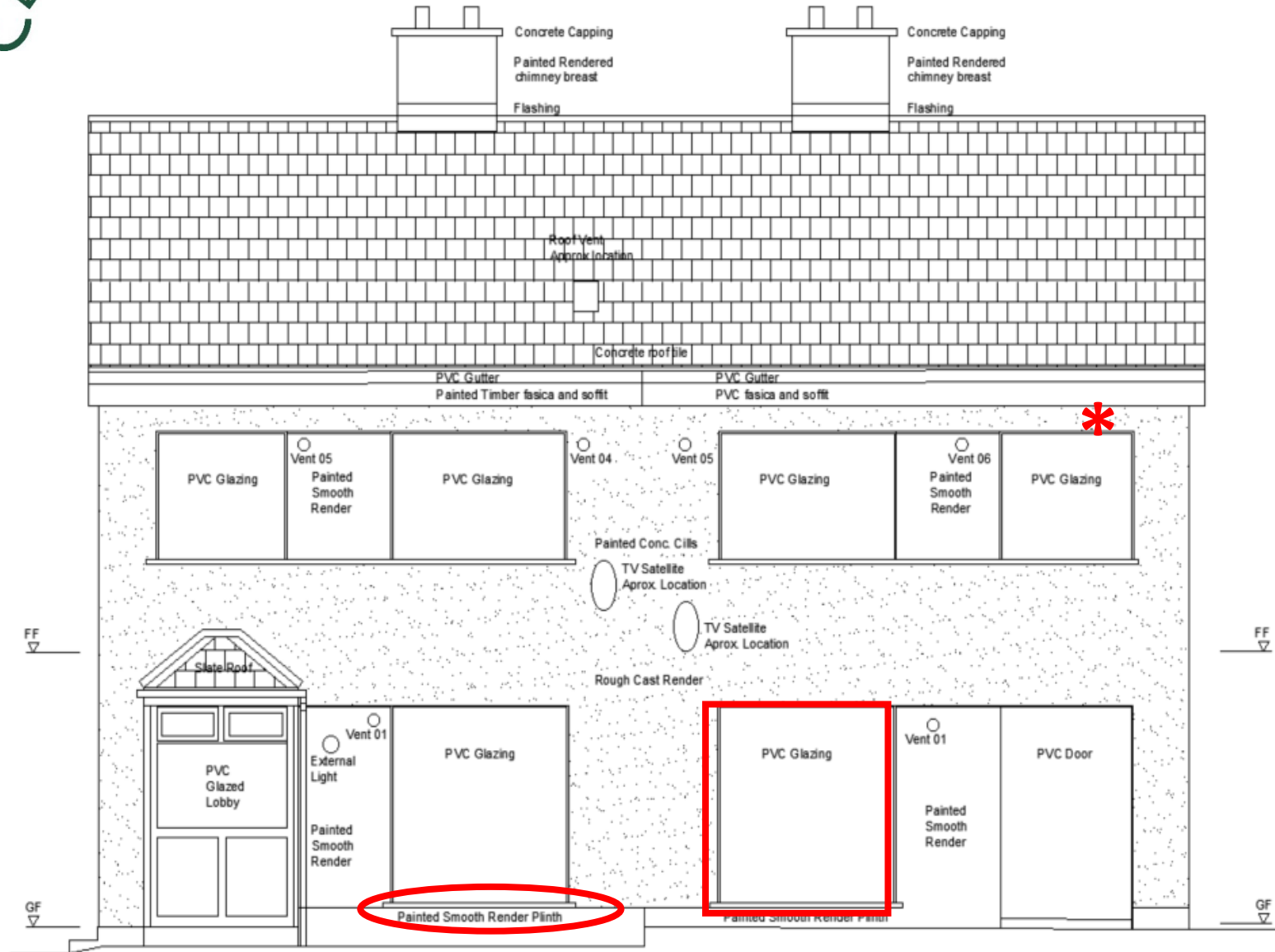

South (Front) Elevation

Lessons Learnt - Data and Survey

Different Types of Survey

Different Data Forms

Different Software File Types

Different Data Users

Survey Data Accuracy

Survey Data Interpretation

Survey Data Application

Co-ord and Management



Digital Data is not GOD



Digital Data is not GOD



Building Stock ?

Survey / Data Strategy Co-ordination and Planning Key Aspect

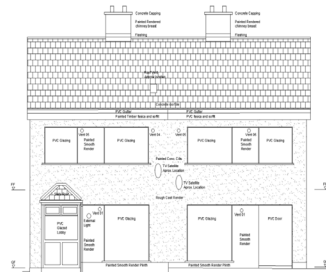

South (Front) Elevation

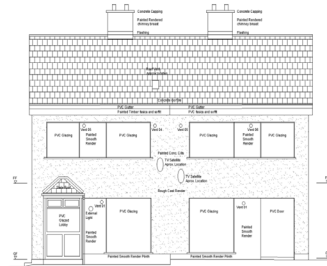

South (Front) Elevation

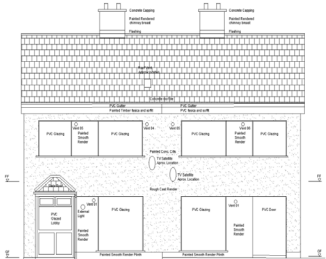

South (Front) Elevation

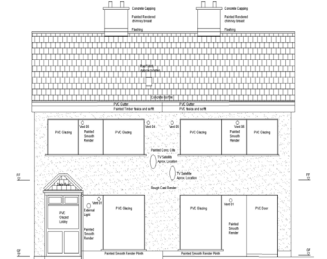

South (Front) Elevation



IRISH PROJECT PARTNERS

SABE - Academic Partner PI



Industry Partner – Design



Industry Partner - Manufacturer



IRISH PROJECT Key Stakeholders

Westmeath Co Co – Building Owner



Contractor - SISK



Specialist Contractors, Suppliers, Installers

ProAir, Aereco, Solar PV Ireland, Next Gen Heat Dist,
Munster Joinery, and others

National Advisory Board



INFO

www.drive0.eu



This project has received funding from the European Union's H2020 framework programme for research and innovation under grant agreement no 841850.

The information in this publication does not necessarily represent the view of the European Commission.

© DRIVE 0

All rights reserved. Any duplication or use of objects such as diagrams in other electronic or printed publications is not permitted without the permission of the project manager.

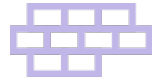

THANK YOU

PATRICK DALY

Patrick.Daly@TUDublin.ie

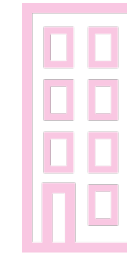

DRIVE



MMA
ARCHITECTS

MMA ARCHITECTS

DIGITAL PROCESSES FOR INSPECTING RETROFIT WORKS'

PRESENTED BY:

MEL MCGERR BSC MSC FCIAT MRIAI(IRL)

DAVID MCGOURTY BSC. PG. CERT. ACIAT

SEAI ENERGY SHOW 2024:

A LITTLE BIT ABOUT MEL....

- FOUNDED PARTNER AND COMMERCIAL DIRECTOR OF MMA ARCHITECTS
- GRADUATED IN BSc. ARCHITECTURAL TECHNOLOGY IN 2002
- MASTERS IN DESIGN MANAGEMENT
- IN 2015 - QUALITY QUALIFICATIONS IRELAND (QQI) FOR AT
- REGISTERED ARCHITECT IN 2016 & FELLOW MEMBER OF CIAT
- EXTERNAL EXAMINER AT ATU (LETTERKENNY & GALWAY CAMPUS'S), TUD AND SETU (CARLOW)
- LECTURED THE BIM COLLABORATION MODULE AT TUS (ATHLONE CAMPUS)

A LITTLE BIT ABOUT DAVID....

- JOINED MMA IN 2019
- GRADUATED IN BSc. ARCHITECTURAL TECHNOLOGY IN 2002
- PG DIP. IN DESIGN MANAGEMENT
- PG DIP. FIRE.
- RECENTLY MADE TECHNICAL DIRECTOR AT MMA ARCHITECTS





ABOUT MMA



- ESTABLISHED IN 2007
- HAVE BEEN DELIVERING PROJECTS OF ALL SCALES AND SIZES FOR OVER 17 YEARS
- ICE AWARD FOR SINGLE RESIDENTIAL DWELLING 2023 - WINNER
- CIAT AWARD FOR TECHNICAL EXCELLENCE SMALL TO MEDIUM 2023 - WINNER
- ATHLONE BUSINESS AWARDS 2023 – SME OF THE YEAR 2023



**Irish Construction
Excellence Awards 2023
Winner**

SUSTAINABLE ARCHITECTURE



- MAJOR ADAPTIVE REUSE PROJECTS – REUSE NOT DEMOLISH!



- OFFICE AND RESEARCH FACILITY – LIMERICK
- EXTENSION TO AND REPRUPOSING OF EXISTING WAREHOUSE INTO 8000 SQ. M. OFFICE AND RESEARCH FACILITY



IRISH LIFE SCIENCES GLOBAL HQ – CIAT AWARD WINNER

- PV INSTALL JAN 2022
- 88000 KWH PRODUCED TO DATE
- EQ. OF 62000 KG OF CARBON SAVED



CASE STUDY PROJECT: - TWO STOREY

TYPICAL DWELLING IN NEED OF ENERGY UPGRADE.

BRIEF: CREATE A MODERN HOME, HIGHLY ENERGY EFFICIENT WITH LOW RUNNING COSTS

THE DESIGN TEAM:

ARCHITECTS: MMA ARCHITECTS

STRUCTURAL ENGINEERS: CCONSULT ENGINEERS

BER ASSESSOR: ATECH ENERGY - MICHEÁL MONAGHAN

MAIN CONTRACTOR: TEKNABUILD (ROGER SMYTH)

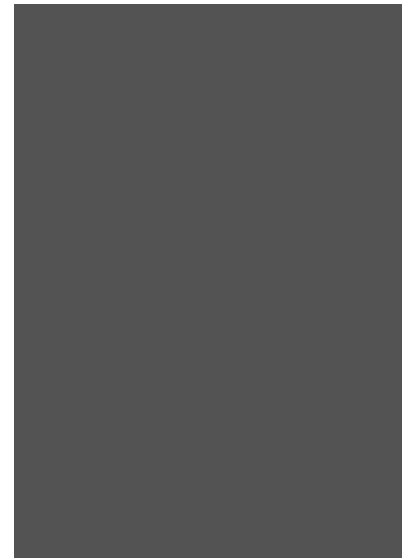

**Irish Construction
Excellence Awards 2023
Winner**

CASE STUDY PROJECT:

TWO STOREY DWELLING, TULLAMORE, CO. OFFALY

GRANTS AVAILED OFF:

- HEAT PUMP
- HEATING CONTROLS
- INTERNAL INSULATION (WALLS)
- ATTIC INSULATION
- SOLAR PV
- BER

OTHER WORKS UNDERTAKEN:

- AIRTIGHTNESS UPGRADES
- MVHR SYSTEM
- RAISED TIMBER FLOORS THROUGHOUT REPLACED (PIR INSULATION INCORPORATED)
- NEW EXTERNAL WINDOWS AND DOORS REPLACED THROUGHOUT
- AIRTIGHTNESS UPGRADE THROUGHOUT



**Irish Construction
Excellence Awards 2023**
Winner





CASE STUDY PROJECT:

TWO STOREY DWELLING,
TULLAMORE, CO. OFFALY

MMA
ARCHITECTS

DIGITAL WORKFLOWS HELPED WITH:

- AUTOMATING THE INSPECTION PROCESS
- MANAGING AND AUTOMATING RAISING AND ADDRESSING NON COMPLIANCE ISSUES
- CONNECTING THIS TO THE CONTRACTOR
- COLLECTION OF CERTIFICATION
- HANDOVER OF DATA FOR THE CLIENT
- PREPARATION OF CERTIFICATION TO SEAI



PRE WORKS BER - E1

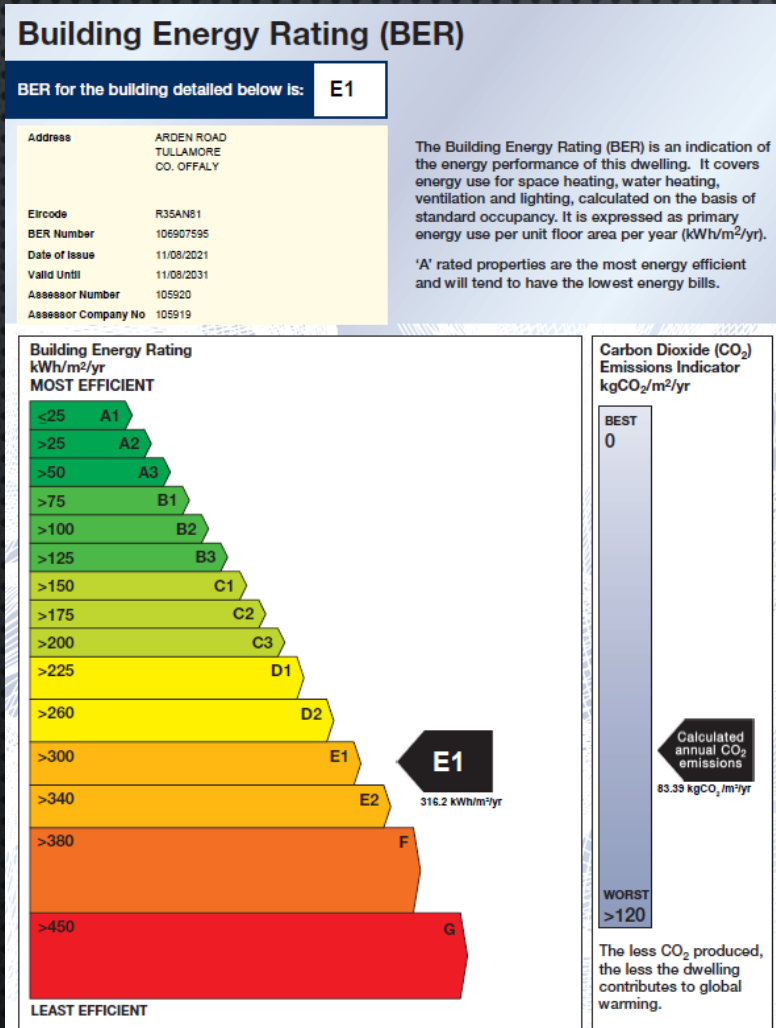

COMPLETED WORKS BER - A1

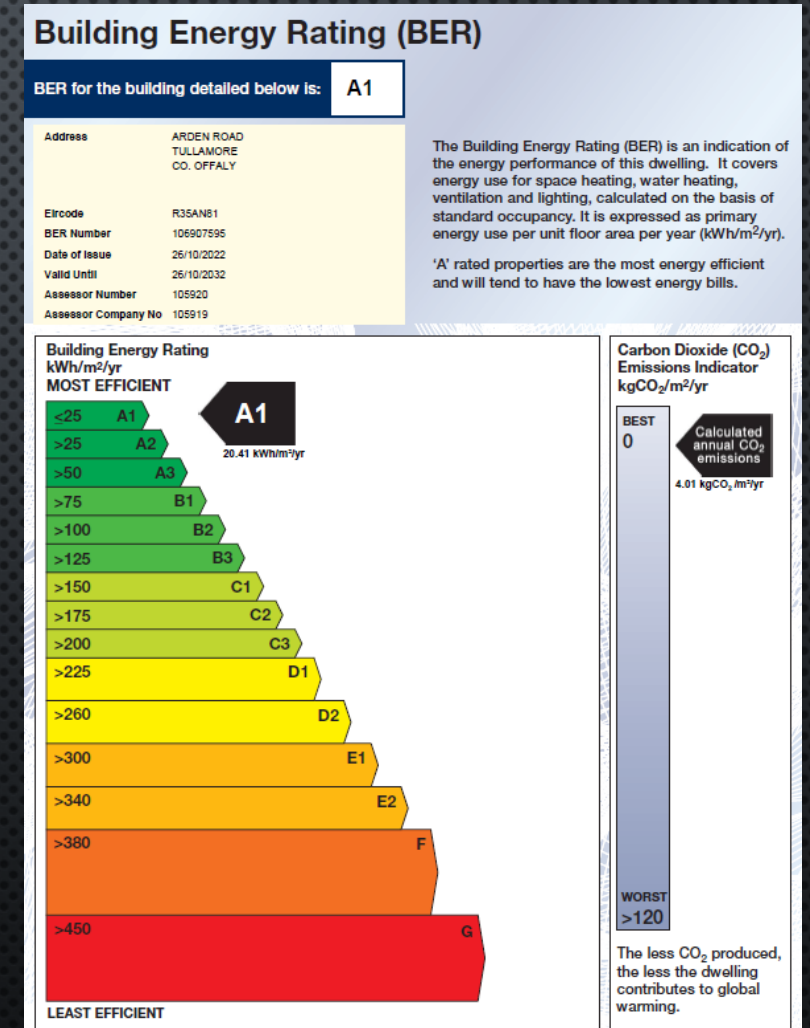

DIGITAL PROCESS

*"eliminating
waste in the
delivery process,
innovating and
learning from
experience"*
EGAN 1998

- MUCH OF WHAT WE DID TO MANAGE THIS AND OTHER RETROFIT PROJECTS, ARE ALREADY IN USE - PARTICULARLY ON LARGER SCALE PROJECTS.
- KEY ASPECT – NO PAPER. ABSOLUTELY NO PAPER!!!
- WE FOLLOW BIM WORKFLOWS, WITH A SIMPLE COMMON DATA ENVIRONMENT (CDE)
- 'BUY IN' REQUIRED FROM ALL CONTRACTORS

MMA ARCHITECTS



THERE ARE SO SOFTWARES AND DIGITAL TOOLS THAT CAN FACILITATE DIGITISING THE PROCESS.



SOME OF THESE ARE EXPENSIVE SOME AND MORE SUITED FOR LARGE SCALE PROJECTS, BUT SOME ARE EFFECTIVELY FREE.

aconex

Sharepoint

conjectPM

ASITE™

Dropbox

AUTODESK
CONSTRUCTION
CLOUD™

Google Drive

Viewpoint®

DIGITAL PROCESSES

HOWEVER, GENERALLY FOR RESIDENTIAL PROJECTS, WE RUN THEM THROUGH AN ONLINE SOFTWARE CALLED ARCTECHPRO.



DIGITAL PROCESSES



A SUCCESSFUL DIGITAL PROCESS WILL DELIVER:

- SIGNIFICANT TIME SAVINGS OVER THE PROJECT LIFE
- EASY ACCESS TO RELEVANT DATA AT ANY LOCATION THROUGH MOBILE DEVICES
- AN AUDIT TRAIL OF WHAT WAS DONE AND WHEN
- SEARCHABLE DATABASE OF INFORMATION
- AUTOMATICALLY GENERATE REPORTS, RAISE ISSUES ETC.

SIGNIFICANT TIME UP FRONT REQUIRED TO IMPLEMENT.

N/A / projects / project home

XXX - Domestic Template



Project Overview

[Share Project](#) [Gantt Chart](#) [Create Multi Unit](#) [Edit Project](#)

Client: N/A
Project Team:
Site Address:
Client Contacts:
Time Frame: No info entered
Estimated Build: €0
Anticipated Fee: €0
Planning Number:
Upcoming Dates: Planning Reference:
Project Share Code: 11194-4E1MCZ

Comments:
Lead:
Support Staff:
Stage:
Category:
Project Activity: [View recent activity](#)

Edit Project

[Show/Hide Sections](#) [Clone Project](#) [+ Staff Sanctions](#) [Save Details](#)

Project Number	XXX
Project Name	Domestic Template
Select Client	N/A
Client Names	N/A
Brief Desc (250 char max)	
Site Address Line 1	
Site Address Line 2	
Site Address Line 3	
Site Address Line 4	
Post Code	
Co-ordinates	
Planning Permission No.	
Pre Validation Ref. No.	
Commencement Notice No.	
Fire Safety Cert	
Disabled Access Cert	
Building Authority	
Estimated Build	0.00
Anticipated Fee (% Build Value)	99.99 % 0.00
Purchase Order No.	
Client Vat No.	
Start Date	
Finish Date	
Project Status	Inactive
Building Control Features	Simple
Project Level	Normal
All users can access	<input checked="" type="checkbox"/>

Project Team:		
Role	Name	Initials
		...
		...
		...
		...
		...
		...
		...
		...
		...

External Uploads Folders

- Ancillary Design Cert's
- Reports & Certifications
- Test Results
- Product Details/Datasheets
- Other

Project Type / Category: 0

Project Director: Mel McGerr

Project Leader:

Comments:

Support Staff:

Lead:

Stage:

Category at Import:

OUR DIGITAL PROCESS – INSPECTIONS

1. WE DEVELOP OUR INSPECTION PLAN (SYSTEMS DESIGNED FOR BCAR BUT WORKS EQUALLY WELL FOR ANY PROJECT) THROUGH THE ONLINE SYSTEM.
2. BASED OF PREVIOUS DEVELOPED TEMPLATE WHICH IS MODIFIED ON A PROJECT BY PROJECT BASIS

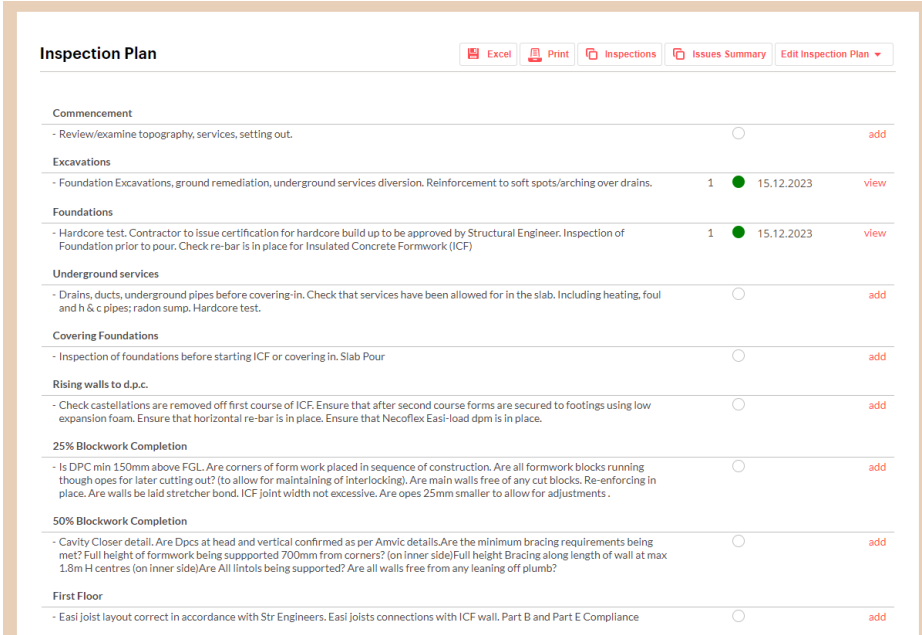

Section	Task Description	Quantity	Status	Date	Action
Commencement	- Review/examine topography, services, setting out.		<input type="radio"/>		add
Excavations	- Foundation Excavations, ground remediation, underground services diversion, Reinforcement to soft spots/arching over drains.	1	<input checked="" type="radio"/>	15.12.2023	view
Foundations	- Hardcore test. Contractor to issue certification for hardcore build up to be approved by Structural Engineer. Inspection of Foundation prior to pour. Check re-bar is in place for Insulated Concrete Formwork (ICF)	1	<input checked="" type="radio"/>	15.12.2023	view
Underground services	- Drains, ducts, underground pipes before covering-in. Check that services have been allowed for in the slab. Including heating, foul and h & c pipes: radon sump. Hardcore test.		<input type="radio"/>		add
Covering Foundations	- Inspection of foundations before starting ICF or covering in. Slab Pour		<input type="radio"/>		add
Rising walls to d.p.c.	- Check castellations are removed off first course of ICF. Ensure that after second course forms are secured to footings using low expansion foam. Ensure that horizontal re-bar is in place. Ensure that Necoflex Easi-load dpm is in place.		<input type="radio"/>		add
25% Blockwork Completion	- Is DPC min 150mm above FGL. Are corners of form work placed in sequence of construction. Are all formwork blocks running though opes for later cutting out? (to allow for maintaining of interlocking). Are main walls free of any cut blocks. Re-enforcing in place. Are walls be laid stretcher bond. ICF joint width not excessive. Are opes 25mm smaller to allow for adjustments.		<input type="radio"/>		add
50% Blockwork Completion	- Cavity Closer detail. Are Dpcs at head and vertical confirmed as per Amvic details. Are the minimum bracing requirements being met? Full height of formwork being supported 700mm from corners? (on inner side) Full height Bracing along length of wall at max 1.8m H centres (on inner side) Are All lintols being supported? Are all walls free from any leaning off plumb?		<input type="radio"/>		add
First Floor	- Easi joist layout correct in accordance with Str Engineers. Easi joists connections with ICF wall. Part B and Part E Compliance		<input type="radio"/>		add

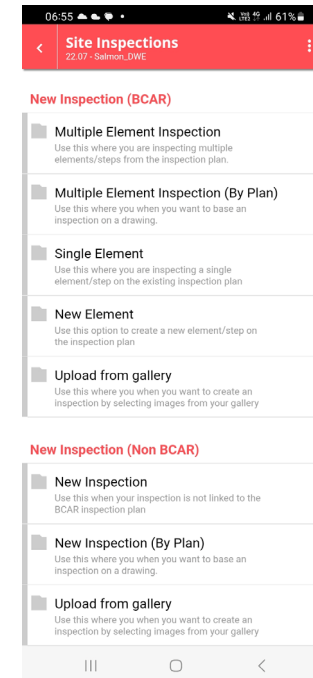

06:55 61% battery

Site Inspections
22.07 - Salmoor_DWE

New Inspection (BCAR)

- Multiple Element Inspection**
Use this where you are inspecting multiple elements/steps from the inspection plan.
- Multiple Element Inspection (By Plan)**
Use this where you when you want to base an inspection on a drawing.
- Single Element**
Use this where you are inspecting a single element/step on the existing inspection plan
- New Element**
Use this option to create a new element/step on the inspection plan
- Upload from gallery**
Use this where you when you want to create an inspection by selecting images from your gallery

New Inspection (Non BCAR)

- New Inspection**
Use this when your inspection is not linked to the BCAR inspection plan
- New Inspection (By Plan)**
Use this where you when you want to base an inspection on a drawing.
- Upload from gallery**
Use this where you when you want to create an inspection by selecting images from your gallery



OUR DIGITAL PROCESS – INSPECTIONS

1. WE DEVELOP OUR INSPECTION PLAN (SYSTEMS DESIGNED FOR BCAR BUT WORKS EQUALLY WELL FOR ANY PROJECT) THROUGH THE ONLINE SYSTEM.
2. BASED OF PREVIOUS DEVELOPED TEMPLATE WHICH IS MODIFIED ON A PROJECT BY PROJECT BASIS.
3. WHEN WE VISIT SITE, WE USE THE PHONE APP TO PHOTOGRAPH AND RECORD THE WORKS.

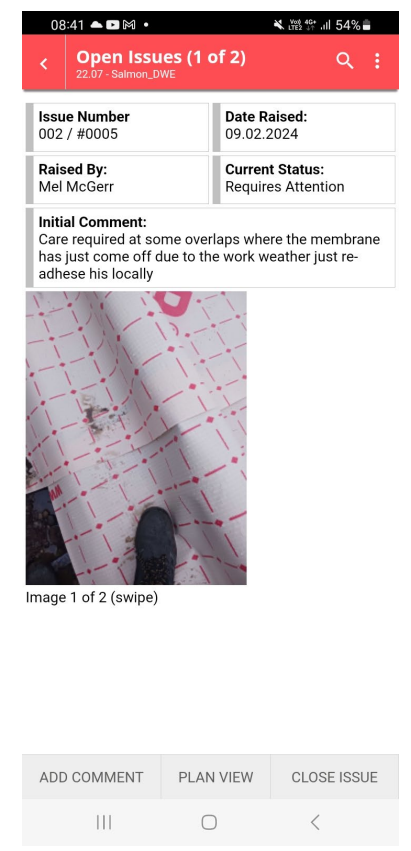
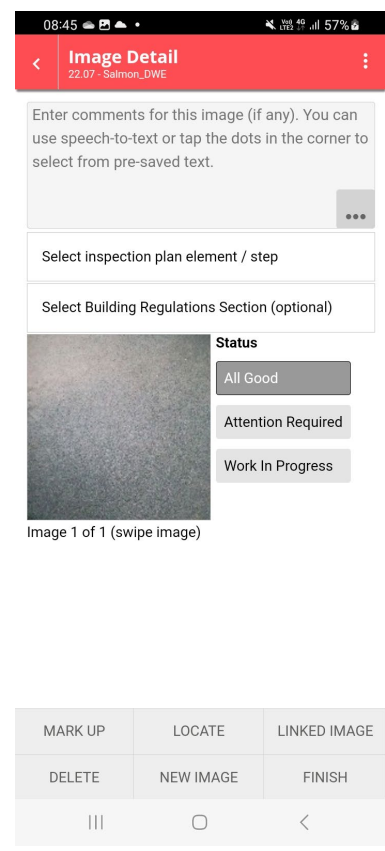
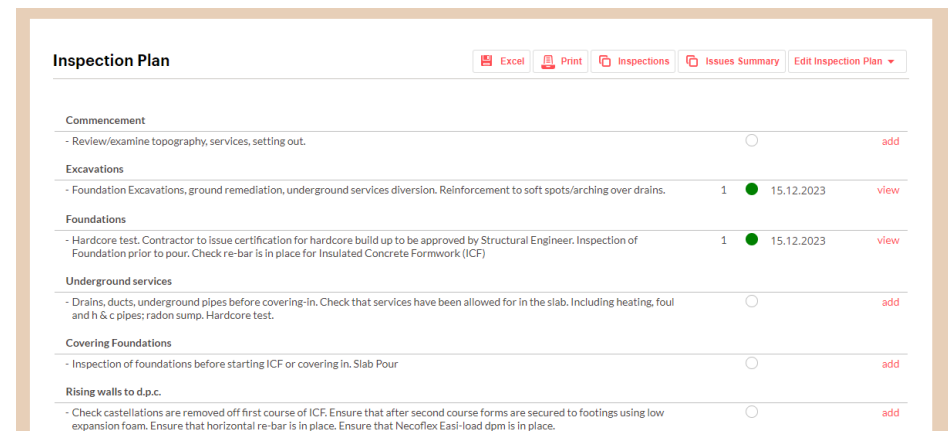
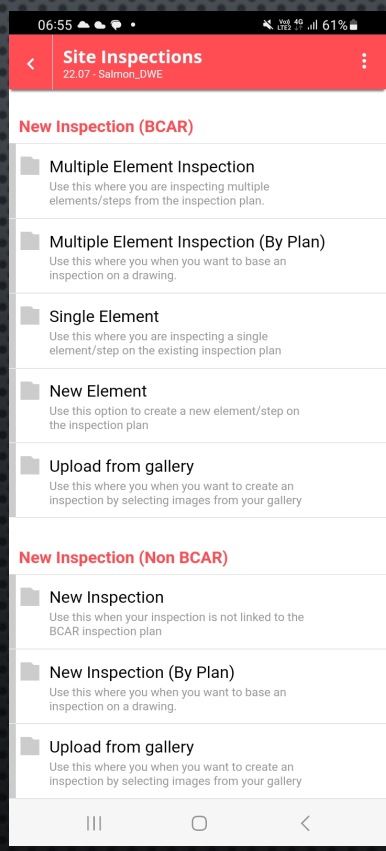

OUR DIGITAL PROCESS – INSPECTIONS

1. INSPECTION REPORT AUTOMATICALLY GENERATED.
2. CONTRACTOR CAN BE ISSUED THIS REPORT IN PDF OR WORD FORMAT.
3. THEY CAN USE THE QR CODE TO DIGITALLY ACCESS A PORTAL AND UPDATE THE ISSUES AND CLOSE THEM OUT.

Site Inspection Report

Project Name:

Client Name:
Domestic

Description
Inspection: 20.06.2023 at 12:22

Prepared By
Mel McGerr

Inspection Date & Time
20.06.2023

Inspection Number
005

Weather Conditions
Sunny and Dry

Printed
13.03.2024 08:51

Findings
31 images / 11 issues

Present During Inspection

BCAR Team

Comments

Their inspection requirements set out in this document do not in anyway relieve, replace or reduce the main contractors duty to supervise the works. It's the responsibility of those concerned with the construction of the relevant building or works (the main contractor) to ensure compliance of such with the most recent Building Regulations. This inspection report does not in anyway warrant, represent or take into account construction changes carried out or changes made to relevant buildings or works after the inspection dates, or works that were covered up at the time of the inspection. The closing out of all items raised in this report is to be based on photographic evidence provided by the Building Foreman as work progresses and based on documentation and confirmations provided by the Main Contractor.

Co Offaly

005 / 010



Comment
Is this junction acceptable?

Current Status
Requires Attention
Location / Plan

Inspection Plan Element
1st Fix Mechanical

005 / 011



Comment
Why is material different here?

Current Status
Requires Attention
Location / Plan

Inspection Plan Element
1st Fix Mechanical

005 / 012

Comment
Why is this damaged.

Issues Identified

Status of any of the issues identified in this report please click on the QR code or visit : sitepal.io and enter reference #

[w these issues in the contractor portal](#)

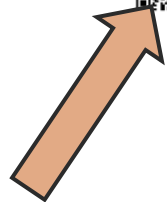

OUR DIGITAL PROCESS – INSPECTIONS

- A SUMMARY OF ISSUES CAN BE GENERATED TO TRACK HOW THERE ARE BEING PROGRESSED

Inspection Issues Summary

[Plan View](#)
[Inspections List](#)
[Excel](#)
[Print](#)

	With Contractor	Ready for Review	All Open	Closed
All Issues	1	0	1	37
By Month				
April 2019	1	0	1	10
March 2019	0	0	0	27
By Type				
BCAR	1	0	1	29
Non-BCAR	0	0	0	8
By Person				
Mel McGerr	1	0	1	37
By Assignee				
Not Assigned	1	0	1	37

The screenshot shows the MMA Architects software interface. At the top, there is a navigation bar with icons for 'Issues summary', 'PDF issues', 'Drawings with issues', 'Notify team of ready elements', 'Excel Tracker', 'Help', and 'Contact Support'. The main content area displays two issue cards. Each card includes a photo of the issue, a metadata table, and a comment section.

Issue: #003/001

Date Raised	02.03.2023
Raised By	Aine Gallagher
Current status	Requires Attention
Assigned To	<input type="text"/> Assign this issue

Issue: #003/002

Date Raised	02.03.2023
Raised By	Aine Gallagher
Current status	Requires Attention
Assigned To	<input type="text"/> Assign this issue

At the bottom of the interface, there are three buttons: 'No comments', 'Add comment', and 'Update to RFR'.

- THE ABOVE IMAGE SHOWS WHAT THE CONTRACTOR WILL SEE.
 - THEY CAN ASSIGN THE ISSUES TO RELEVANT SUBBIES
 - UPDATE AND ADD INFORMATION AND SUBMIT FOR US TO REVIEW.



OUR DIGITAL PROCESS – SUBMITTALS & CERTIFICATES

- A FULL LIST OF DOCUMENTS FOR SUBMITTAL IS SET UP FOR THE PROJECT.
- THE CONTRACTOR HAS ACCESS TO THIS LIST AND CAN UPLOAD THIS DOCUMENTATION AS A REPOSITORY OF THE DATA UNTIL REQUIRED FOR SUBMISSION.
- THIS GIVES THE CONTRACTORS A CLEAR GUIDE AS TO WHAT IS REQUIRED FROM THEM.
- SUBMISSION ARE DATED WHEN RECEIVED, COMMENTS ADDED ETC.

Requirement Description	Due From	Type	Status	History
Structure				
Structural Calculations Ed Ei Ec both for the frame and foundations	01.02.2023	Other	Signed Off	3 Edit More ▼
Fire Detection and Alarm System				
Ed Ei Ec Certs and IS 3218:2023 cert from Subcontractor	01.02.2023	Other	Uploaded	2 Edit Approve More ▼
Electrical Certs				
Electrical Installation Completion Certificate - RECI - Electrical Sub-Contractor	01.02.2023	Other	Signed Off	2 Edit More ▼
Emergency Lighting				
Emergency Lighting Design Certificate I.S. 3217:2013 M&E Consultant. Emergency Lighting Installation Certificate I.S. 3217:2013 Subcontractor. Emergency Lighting Commissioning Certificate I.S. 3217:2013 - Subcontractor. Emergency Lighting Handover Certificate I.S. 3217:2013- Sub Contractor	01.02.2023	Other	Uploaded	* 1 Edit Approve More ▼
Part L Compliance				
Sd Si and Sc ancillary certs from Energy consultant	01.02.2023	Other	Uploaded	2 Edit Approve More ▼
Ventilation				
Room Windows Passive Ventilation - Confirmation letter of Design Compliance - PMcVey	01.02.2023	Other	Signed Off	2 Edit More ▼
Heating				
Ed Ei and Ec M & E consultant	01.02.2023	Other	Uploaded	* 1 Edit Approve More ▼
Fire extinguishers				
Noting compliance with I.S. 291:2015	01.02.2023	Other	Not received	Edit More ▼
Materials				
Letter of Compliance with the Building Regulations - PMcVey Metal Stud Partitions - Fire and Structural Integrity Confirmation Letter - PMcVey Floor Finishes - Slip Resistance Confirmation - PMcVey Millwork/Furniture - Confirmation of Materials Compliance - PMcVey Sanitaryware - Confirmation of Materials Compliance - PMcVey	01.02.2023	Other	Uploaded	* 5 Edit Approve More ▼
Air tightness Report				



OUR DIGITAL PROCESS - KEY POINTS/LEARNINGS

1. FORGET PAPER
2. REQUIRES 'BUY IN' FROM ALL PARTIES – IN PARTICULAR CONTRACTORS
3. REQUIRES SIGNIFICANT 'UP FRONT' TIME TO SET UP, HOWEVER, THE TIME WILL BE RECOUPED IN MULTIPLES OVER THE COURSE OF THE PROJECT.
4. WE SHOULD ALWAYS CONSTANTLY REVIEW AND IMPROVE OUR PROCESSES/
5. USE A TEST PROJECT TO GET STARTED
6. SET UP COSTS CAN BE MINIMAL AND TOOLS SUCH AS DROPBOX ETC. CAN BE USED – HOWEVER YOU WILL LIKELY NOT BENEFIT FROM SOME OF THE AUTOMATED PROCESSES AVAILABLE FROM BESPOKE SOFTWARES.
7. MAJOR GAINS ON QUALITY CONTROL THROUGHOUT THE CONSTRUCTION STAGE.
8. INTERNET CONNECTIVITY REQUIRED ON SITE (HOT SPOT OF PHONE FOR TABLETS)

MMA
ARCHITECTS

THANKS TO THE TEAM INVOLVED



CCONSULT
ENGINEERING DESIGN

TEKNABUILD

BAYSIDE
HEATING AND
PLUMBING

MMA
ARCHITECTS

THANK YOU



mel-mcgerr-architect

WWW.MMAARCHITECTS.IE

Melmcgerr_arch



Upscale your Operations with Best-in-Class Energy Upgrades Solutions



SEAI Energy Show
Wednesday March 20th



Digital Innovations to Enable Scale in the Domestic Retrofit Market

Liam Donohoe: Senior Consultant, RetroKit



We help OSS and BER assessors that are struggling to scale up their home energy upgrade service succeed by accelerating the process from homeowner enquiry to shovel-ready projects, with reliable high-quality outcomes for all involved.

Who uses RetroKit and Why?



Rita, Sales team, One Stop Shop



Barry, Independent BER assessor



Social Housing Body engineer

Rita – Sales Team at OSS / CEG



Hard Deadlines / Client Demands

Target it to answer 200 calls a week
25% conversion rate
Works with the technical team to move these leads to HEA and finally onto retrofit projects.



Different types of projects

Extensions
Attic conversions
Derelict houses
Ordinary retrofits



Design Options

Homeowner wants an **accurately priced** retrofit plan with **detailed scope**.

Rita – Sales Team at OSS / CEG



“RetroKit empowers me to get back to customers quickly with an initial estimate and sales brochure and as a next step working with the engineering team and assessors to deliver **accurate, costed, ‘shovel ready’ Home Energy & Technical Assessments better and faster”**



OSS/CEG

Mapping Tool

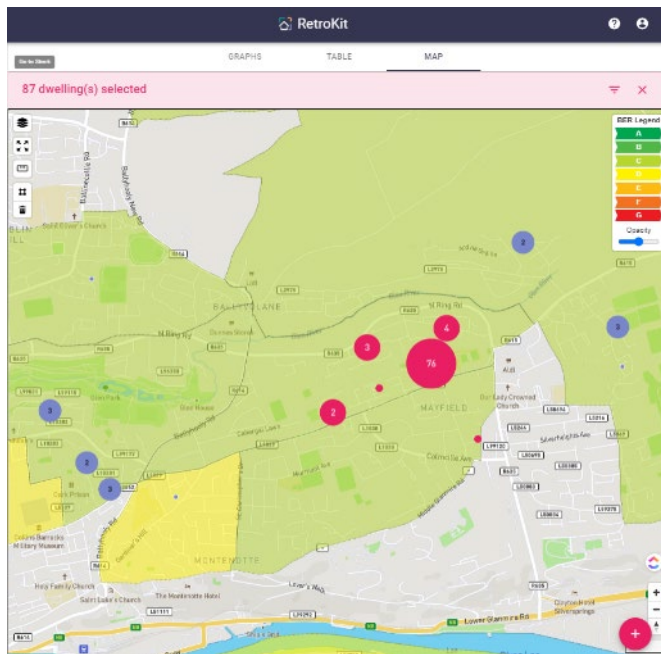

Build a Scenario Library

SCENARIOS	DWELLINGS	CREATED
2	16	16th Mar 2023

Name	Description	Measures	Type	Actions
SEAI HEA with PV	SEAI HEA with PV	11	Person	+
SEAI HEA	SEAI Best Practice HEA	11	Person	+

MPRN	Street	Area	Town/City	County	Postcode	Scenario
0	13 Corran	Granhna	Cork	Cork City		SEAI HEA with PV
1	12	Ballinsheen Court	Machain	Cork City	T12 C9C5	SEAI HEA A2
2	44	Clashduv Road	Cork	Cork City		SEAI HEA B2
3	2 Corran Ogramhna	Ballyphehane	Cork	Cork City		SEAI HEA A3
4	72	Avonmore Park	Cork	Cork City	T23 EPW1	SEAI HEA B1

Customise Measures

Name	Fixed	Variable	Multiplier	Unit	Type	Actions
Deep Draught Proofing	€357.50	€8.47	Floor area	m²	Bi	-
Fit Mechanical Demand Control Ventilation	€3602.50				Bi	-

Name	Fixed	Variable	Multiplier	Unit	Type	Actions
300mm Attic Insulation on Ceiling	€715.68	€30.66	Ceiling area	m²	Person	-
Cavity and External Wall Insulation 0.21 W/m²K		€203.50	Wall area	m²	Bi	-
Internal Insulation Upgrade to Insulated Sloping Ceiling	€715.68	€67.57	Flat roof, pitched roof and room in roof area	m²	Person	-
Replace Door		€585.75	Door area	m²	Bi	-

Barry - Independent BER Assessor



Survey to Design

My team and I want to share common designs and use / re-use them



Design to Report

SEAI-templates must show HLI and uplift criteria for energy credits and grants



Design Changes and Scope

I know what the Homeowner wants because I have been in their home talking and listening to them.

Barry - Independent BER Assessor



“RetroKit enables me to produce SEAI-approved HEA’s and Technical Assessment Forms in minutes”

“My reports look professional” and *“the wizard is working well and is easy to use”*



BER Assessor

Easy to use wizard

Technical Assessment Admin Sign Walls Roofs Floors Windows Doors Openings Sealing MV X

Admin Information and Homeowner Declaration

Homeowner

Name

Is address same as the dwelling?

Address

County

Eircode

Signature

Date DD/MM/YYYY

Dwelling

Address 12

Ballinsheen Court

Machain

County Cork City

Eircode T12 C9C5

Floor area m² 88

Year constructed 2002

BER 2

MPRN 1

Heating system Mains Gas

Efficiency % 73

Scenario: DeepT

NEXT

Pre-filled Technical Assessment

Technical Assessment Form for Better Energy Homes Heat Pump System Grants (V0.3)



Administrative Information		Homeowner Address		Dwelling Address (Only if different from HO address)	
Name*	John Doe	Address 1	13 Corran	Address 2	Gramhna
Address 1*		Town/City	Cork	County	Cork City
Address 2		County*	0	Eircode	
Town/City*		Eircode*		Dwelling address same as homeowner address?	<input type="checkbox"/> Yes <input checked="" type="checkbox"/> No
Cost of Technical Advisor Service	€* 0	Total Floor Area and Year Constructed	Floor area [m2]* 88	Year Constructed*	2002-08-31
		Dwelling Identification Numbers	BER No. * 1	MPRN No. * 0	
Technical Advisor Details					

Cost of delivering the service includes advice, Technical Assessment and, if carried out, a BER publication prior to works. Don't include cost of BER post works in this figure. SEAI do not charge a fee for

Customisable HEA

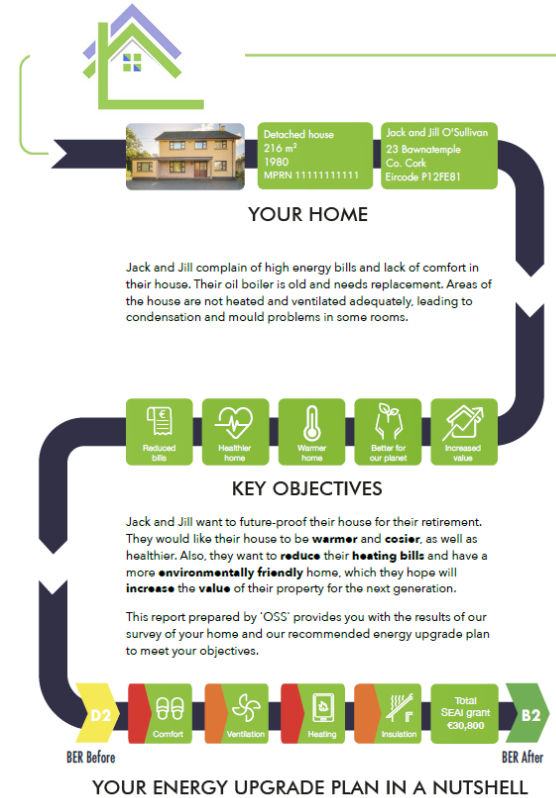

Bankable Report



Energy Upgrade Cost Estimates

Steps	Energy Upgrade Measures	Cost € incl. VAT	Grants
1	Attic insulation (300 mm above ceiling)	2,877	3,000
2	Sloping ceiling insulation	8,536	3,000
3	Cavity and external wall insulation	32,410	8,000
4	Complete upgrade of windows with double glazing	18,717	4,000
5	Replace external doors	2,885	800
6	Airtightness	2,479	1,000
7	Mechanical ventilation (demand-controlled)	4,088	1,500
8	Install air to water heat pump with new cylinder and heating controls	10,131	8,500
9	Upgrade central heating system with new radiators associated pipeworks	5,137	2,000
10	Project management	5,675	2,000
	Total	92,935	
	Total SEAI Grant		30,800
	Energy Credits from Energy Efficiency Obligation Scheme		2,569
	Total cost to the homeowner	59,566	
11	Optional - Install solar PV (2 kW)	6,592	1,800

Schedule of payments:

... % deposit on signing the contract, ...% milestone 1, ... % milestone ..., final payment on ...

Financing option:

To find out more about the green loan offered by our partner The Green Genie Bank, with a preferential low-interest rate of ... %, please contact ...

Customer-Centric

- Co-creating solutions with clients
- Integration with Customer Platforms
- Ready to go yet customisable



Volume-based **competitive pricing offer**

Dedicated Customer Success support and effective **Onboarding Plan**

SEAI 'Trusted Partner' API and keen insight into ongoing market developments



RetroKit – the Professionals' Tool of Choice

Call Xavier on + 353 86 0476124

Liam on +353 87 1953301

Visit us at Stand J14 – LIVE DEMO AT 4.30 TODAY

www.retrokit.eu

xavier@retrokit.eu

liam@retrokit.eu

LinkedIn: <https://www.linkedin.com/company/retrokit/about/>

Twitter: [@RetroKit_EU](https://twitter.com/RetroKit_EU)

BERWOW

Innovators in the **Retrofit** Market

Michael Hanratty
mhanratty@berwow.ie



BERWOW Origins

Partnership formed in 2015:

IHER Energy Services/ Gamma Labs / Fintan Smyth



IHER role in developing Irish Building Typology TABULA & EPISCOPE since 2009



Gamma Labs developed BER mapping for North Dublin on EPISCOPE project in 2015
- locational Intelligence solutions providers



Fintan – expert input to Better Energy Financing in 2013

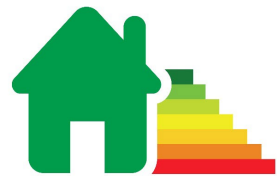

IHER Energy Services Ltd



Gamma Labs

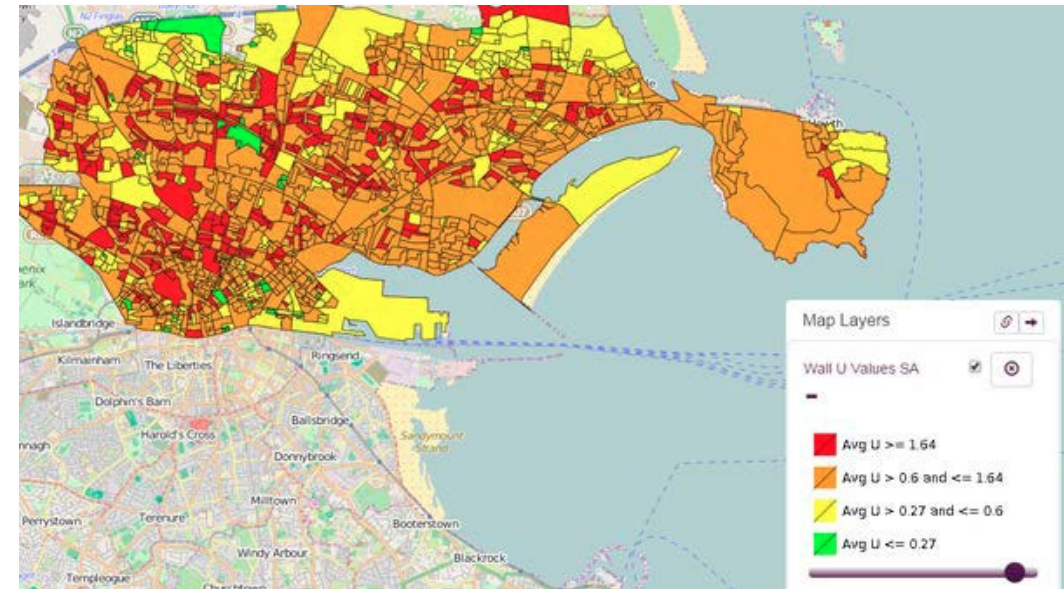

BERWOW Origins



Partnership responded to SEAI innovation research calls in 2015 & 2016 to create BERWOW



BERWOW was market ready in December 2017



Introduction of GDPR (May 2018) required clarity on BER data ownership - SI 243 27.4(c)

Final resolution by June 2021 with signing of Trusted Party Agreement to enable access to homeowners' BER data



BERWOW

How it Works – The Core Engine



At home For business SSE Reward Customer Support

Help Contact us Republic of Ireland

sse Airtricity

About Us Plans Home Upgrade Pay Now eStore Login

Generation Green Home Upgrade

Make your home cosier and more energy efficient

Home Upgrade Calculator

A 'One Stop Shop' for home upgrades

We can help you retrofit your home, improving warmth, and lowering your bills*. Wondering what it is really like to upgrade your home? Read about [Anne and Aiden's journey](#) to an A-rated home.

[Video Link](#)

Launched with SSE in August 2020

New Functionality in Pipeline





Newer BERWOW version by mid 2024 using BER data end-points to feed into OSS processes.



Developing versions for international markets.

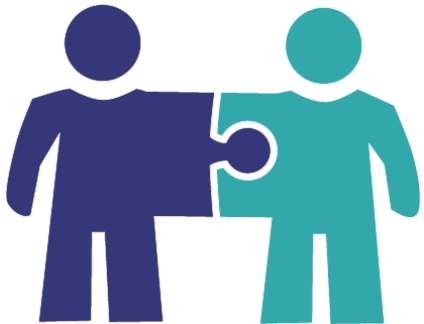

Developing Building Renovation Passport tools through the EU One Click Reno project.

BERWOW

Thank you!

Michael Hanratty
mhanratty@berwow.ie





Prime19

**Digital Innovations to
Enable Scale – The
Prime19 Products**

Challenge Area: Home Retrofits

1 Government's Targets

- ▶ Residential homes account for **24% of energy related CO2 emissions** and 10.2% of total GHG Emissions with
- ▶ Irish homes 60% higher than EU average GHG emissions
- ▶ Ireland's Long-Term Renovation Strategy seeks **500,000 homes to be retrofitted to a BER of B2 by 2030**
- ▶ Only approximately 7,000 retrofits to B2 were completed in 2022

2 Barriers to Retrofitting

- ▶ Homeowners **don't know where to start**, struggle to find any helpful guidance and find the **process very complicated**
- ▶ **Availability of contractors** to complete the work required
- ▶ Significant upfront investment required with historic lack of finance options
- ▶ Consumers **not fully aware of the benefits of retrofitting** including energy savings

3 The Opportunity

- ▶ The **SEAI BER Database contains a wealth of information on c.1m homes** in the country
- ▶ Prime19's skillset of **analytics, data and technology**, means we are perfectly positioned to maximise this potential
- ▶ Through **cutting edge use of data analytics** and bringing the full retrofit ecosystem together in one place, **the retrofit process can be demystified**

1

Our Solution: www.YourRetrofit.ie

What we have developed as an SEAI trusted partner – to date ...

The screenshot displays the 'YourRetrofit.ie' website interface. At the top, there is a green navigation bar with the logo and tagline 'YOUR HOME, YOUR BUDGET, YOUR WAY' on the left, and links for 'Home', 'Retrofit Journey', 'About Us', 'My Portfolio', and 'Logout' on the right. Below the navigation bar, there are three numbered steps: '1 Home Overview', '2 Upgrade Options', and '3 Next Steps'. The main content area is divided into several sections:

- Your home details:** Includes a map of Ireland with a location marker, an address (13 Ellesmere, Brewery Road, Stillorgan, Dublin), and property details (Type: Semi-detached, Size: 109m², Stores: 2, Built: 1988, BER Date: October 2014). Energy details show 'Rating: Mains Gas' and a 'C2' energy label.
- Energy performance of your home:** A bar chart shows energy performance levels from G to A1. The current performance is at C2, and the potential is at A2. Below the chart are progress bars for different home components: Roof, Walls, Windows, Floor, and Space Heating.
- Benefits of moving from BER C2 to BER A2:** A grid of service recommendations from Chadwicks, electric Ireland, and FBD Insurance, highlighting benefits like free consultations, energy savings, and home insurance.

A green button at the bottom center says 'See your tailored upgrade options'. The bottom left of the screenshot shows a URL: 'https://www.yourretrofit.ie C2'.

1

Our Solution: www.YourRetrofit.ie

What we have developed as an SEAI trusted partner – to date ...

The screenshot displays the 'Specify your budget' section of the YourRetrofit.ie website. At the top, a green navigation bar includes the logo and the tagline 'YOUR HOME, YOUR BUDGET, YOUR WAY', along with menu items: Home, Retrofit Journey, About Us, My Portfolio, and Logout. Below the navigation, a progress indicator shows three steps: 1 Home Overview, 2 Upgrade Options (active), and 3 Next Steps. The main content area features a 'Specify your budget' slider set to €42,000. Three package options are presented:

- Budget Optimal Package (€36,050):** BER C2 To BER A3. Benefits include €11,300 in SEAI grants available, saving €1,525 per annum on mortgage, €575 per annum on energy bills, and €75 per annum on home insurance. It follows the Individual Measures Route.
- B2 Package (€11,400):** BER C2 To BER B2. Benefits include €4,800 in SEAI grants available, saving €1,525 per annum on mortgage, €350 per annum on energy bills, and €75 per annum on home insurance. It follows the Individual Measures Route.
- Quick & Simple Package (€3,100):** BER C2 To BER B3. Benefits include €2,000 in SEAI grants available, saving €1,525 per annum on mortgage, €225 per annum on energy bills, and €75 per annum on home insurance. It follows the Individual Measures Route.

Each package has a 'Select package' button and a 'View Details' link. A 'CHADWICKS LET'S GET IT DONE' logo is visible in the bottom right corner of the interface, with a 'Free consultation Book now' button.

1

Our Solution: www.YourRetrofit.ie

Overview of the Functionality

- ▶ A fundamental building block of our Consumer Platform is that it is to be an **entirely free to use service for the homeowner and publicly available to all**
- ▶ The Platform has been designed to **demystify and guide consumers through their home retrofit journey**. To enable this, the layout and functionality have been designed to provide a service which is tailored to everyone's home
- ▶ The functionality is **designed to cater for all consumer types including prospective homeowners or renters and homeowners who don't have a BER**
- ▶ Within the platform consumers will be taken through the following steps:
 1. **Overview:** An overview of their specific home's current and potential energy rating, including the main areas in their home which are contributing to its energy loss
 2. **Upgrade Options:** Tailored upgrade packages with options ranging from quick and simple upgrades to deep retrofits. These packages include details on costs and available grants
 3. **Costs & Benefits:** A detailed breakdown of the upgrades selected, along with the grants available to you and estimated cost. Expected benefits such as discounted mortgage rates, materials, insurance and energy bills
 4. **Next Steps:** Appointment booking to visit a branch of our building supplier to receive guidance and support to work through the home specifics, provide direct link to our financing partners regarding mortgage or loan products, connection to the network of contractors available to undertake work

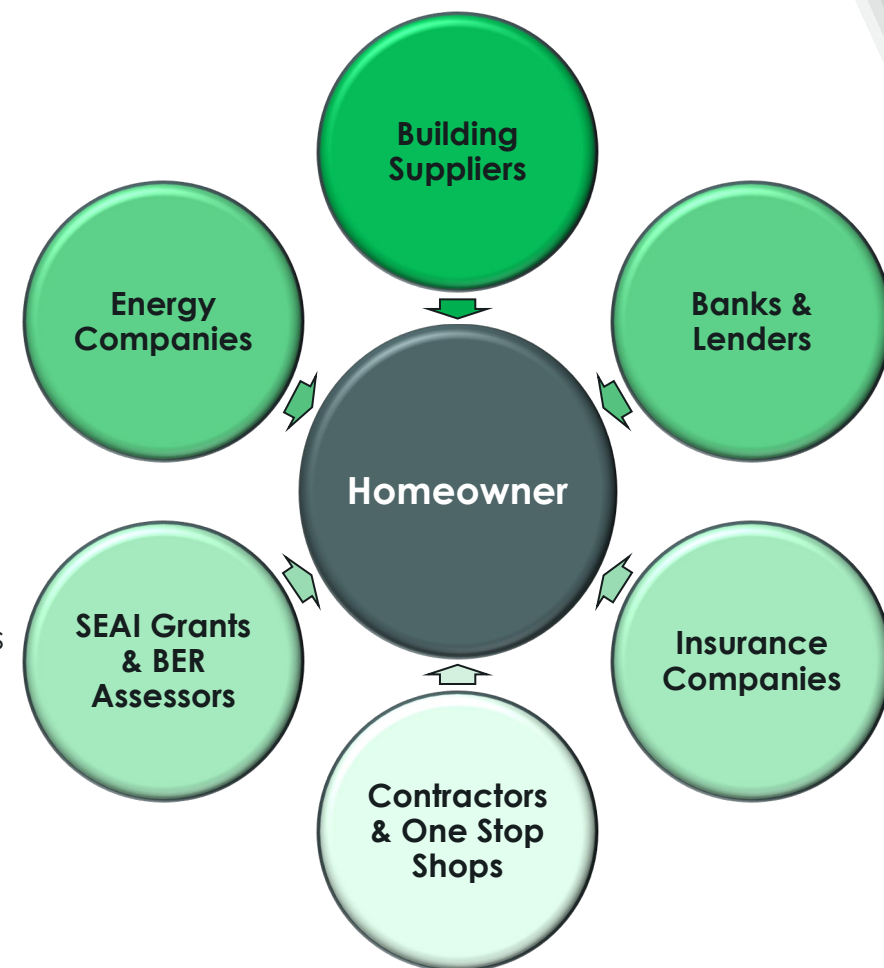

2

Our Solution: Industry Expert Platform

What we have developed as an SEAI trusted partner – to date ...



Address

34 Priory Avenue
Stillorgan
Dublin
A94CP21

Property details

Type: Semi-detached
Size: 113m²
Stories: 2
Built: 1951

Select a property...

MPRN	Customer Name	Eircode	Date Submitted
10001805576	Test Property5	D06A378	Nov. 7, 2023
10003723035	Sample Property 4	D13R867	Nov. 7, 2023
10005467858	Sample Property 6	A94YV70	Nov. 7, 2023
10005074997	Sample Property 3	A94YV70	Nov. 3, 2023

Overview of energy rating

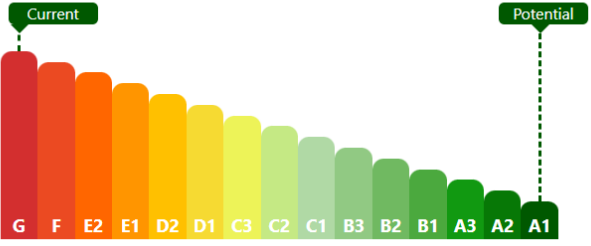

Walls

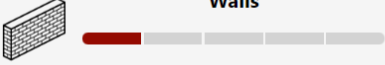

Total area: 146.91 m² U-Value: 0.18 - 2.10
Types: Unknown & Cavity - Filled

Roof

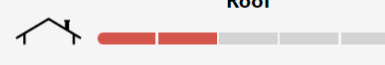

Total area: 63.70 m² U-Value: 0.40 - 2.30
Types: Pitch - Ceiling Insulated & Flat

Floor



Total area: 63.61 m² U-Value: 0.65
Types: Suspended Floor

Windows

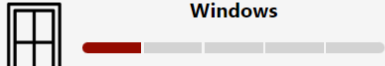

Total area: 21.24 m² U-Value: 3.10 - 3.70
Types: Double Glazed

Door

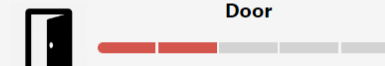

Total area: 5.33 m² U-Value: 3.03 - 3.06

Space Heating

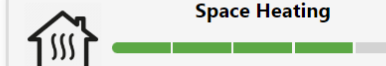

Primary System: Electricity Primary Efficiency: 100%
Secondary System: Solid fuel

Water Heating

Renewables

Ventilation

2

Our Solution: Industry Expert Platform

What we have developed as an SEAI trusted partner – to date ...

Select your upgrade package

Minimum OSS (Heat Pump) €76,518

BER G To BER A3

Minimum OSS €54,428

BER G To BER B2

Comprehensive Package €110,178

BER G To BER A1

See what your package includes and select categories to customise

Roof

✓ Roof Insulation

Floor

Heating

✓ Heat Pump with Plumbing
✓ Remove Secondary Heating

Ventilation

✓ Air Tightness
✓ Ventilation system

Walls

✓ External wall insulation

Windows & Doors

✓ Exterior doors

Lighting

Renewables

Customise your upgrades

Roof	Mix - Attic floor and Flat roof insulation
Walls	
Floor	
Windows & Doors	
Heating	
Lighting	
Ventilation	
Renewables	

Mix - Attic floor and Flat roof insulation

Cost: €4,040
Grant: €1,300
Net Cost: €2,740

[Remove Upgrade](#)

Attic Floor Insulation

Unavailable for this property

Rafter Insulation

Unavailable for this property

Apply upgrades to property

Choose your upgrade route

Individual Measures

One Stop Shop

- ✓ Home built pre-2011
- ✓ Current BER of B3 or worse
- ✓ Minimum BER of B2 is achieved after your upgrades
- ✓ Reduce your energy usage by 100 kWh/m²/year

Upgrade Summary

BER G To BER A3

Estimated BER	71.94
Estimated HLI	1.95
Energy Saving	393.87 kWh/m ² /year
Labour & Material	€70,060
Project Management	€6,150
Post-Works BER	€308
Total Grants	€20,500
Net Cost	€56,018

2

Our Solution: Industry Expert Platform

Benefits of the Platform



Enhance customer service

- Using the Prime19 software significantly reduces customer waiting times for follow up at each point
- The time from initial customer enquiry to commencement of the work is reduced significantly
- Customers receive very comprehensive Home Energy Assessments in less than half the time



Create efficiencies

- Using our software frees up significant time for the Sales and Technical teams
- Paperwork is significantly reduced and information collected only once, then stored centrally
- Automation of many processes including HEAs, quotes and SEAI documentation

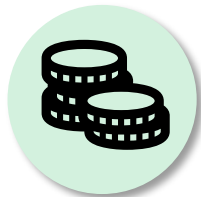

Reduce costs

- The most significant cost saving is the additional resource capacity freed up across teams
- Using our software enables the production of grant qualifying HEAs in half the time
- It also saves significant resource and outsourced partner time for iterations of HEAs etc



Enable customisation & scalability

- Our 13 in-house developers enable the creation of specific customised requirements in short order
- By delivering the significant efficiencies above we enable you to greatly scale customer numbers
- Onboarding new staff becomes much more structured, enabling them to hit the ground running

2

Our Solution: Industry Expert Platform

Impacts of the Platform

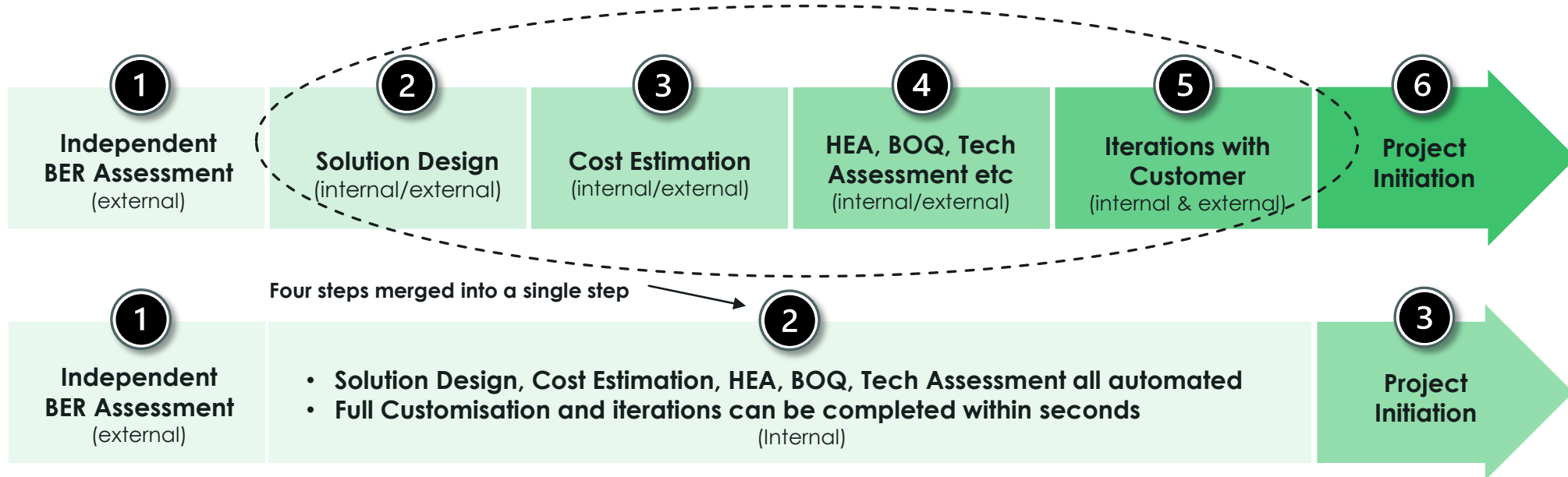

- Our Platform produces **automated documentation** and SEA1 qualifying material
- Can be **used on-site**

- Full **instant customisation** for the complex cases
- Pricing and documentation is all integrated** thus saving significant resource time

- Our clients have seen up to 70% time efficiency in the advancement of customers to the project initiation phase

- Errors and problems with **inconsistencies are removed**

Prime19 Tech Stack

Key benefits of what we have developed

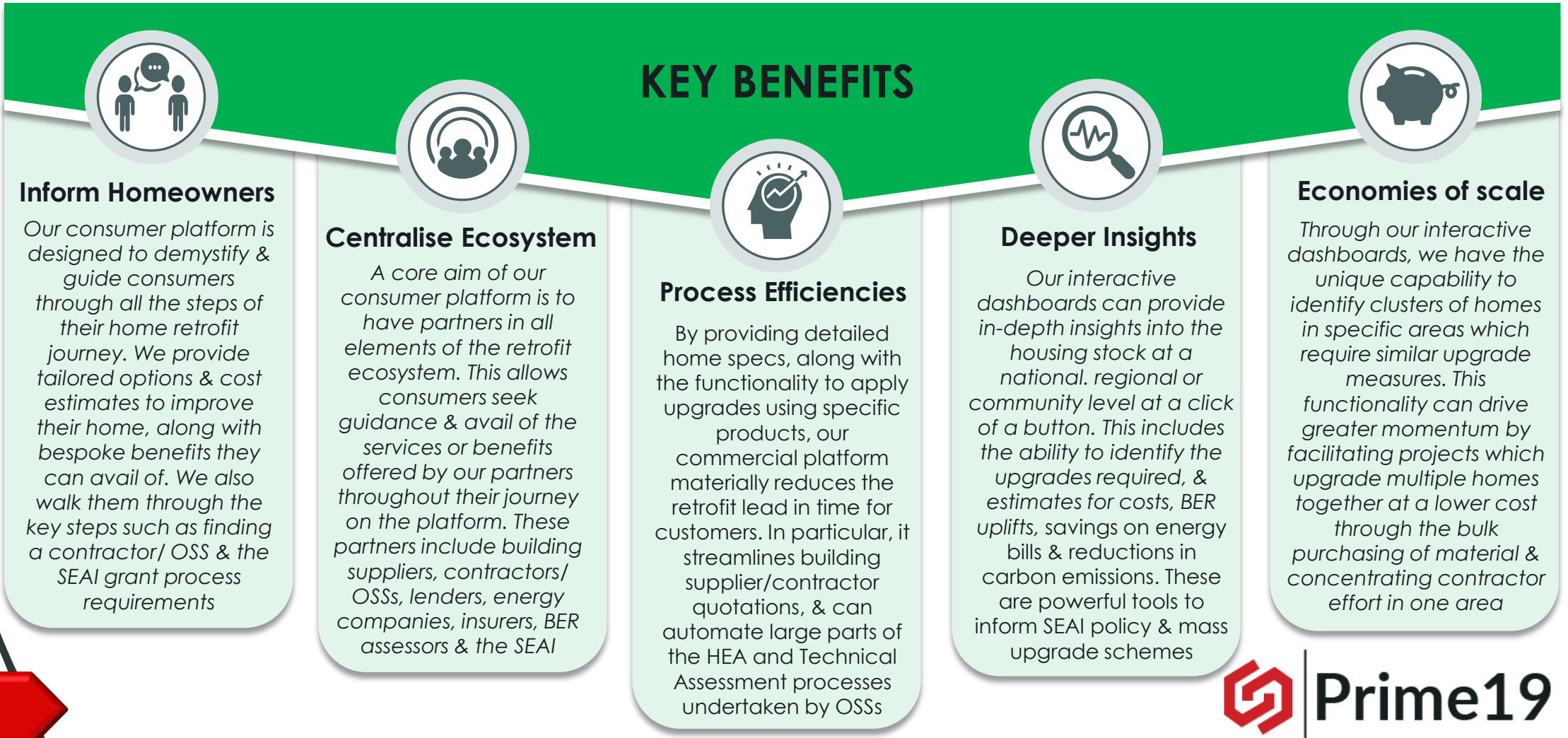

Thank You!

What's Next

We are continually developing our software capabilities to ensure that we can maximise our contribution to this invaluable work driving forward the achievement of the Government's Climate Action Plan

We would love to discuss any thoughts or requests you may have to see how we could be of help – please do get in touch



DavidShiel@Prime19.ie

087 341 7479

NAS API Data Service

Access BER Data and DEAP

Kevin Raheem, 20/03/2024

NAS Trusted Partner API Introduction

BER Search – National BER Register

seai SUSTAINABLE ENERGY AUTHORITY OF IRELAND

National BER Register

Facilitating Ireland society based on technologies and

Enter the BER number or the MPRN to review the BER Certificate for the property and then press Search.

BER/DEC Number: ? BER/DEC Number is assigned to a building when the first BER/DEC is published. It is a 9 digit number printed on the BER/DEC Certificate.

MPRN: ? Meter Point Reference Number (MPRN) is the ESB meter number for the building. It is an 11 digit number printed on your electricity bills.



BER Details - Dwelling

Contact SEAI Search Again

BER/DEC

Address: [Redacted]

Date Of Issue: 15-04-2023

Type Of Rating: Existing Dwelling

Date Valid Until: 15-04-2033

DEAP Version: 4.1.0

Building Energy Rating: C3 213.07 (kWh/m²/yr)

BER/DEC Number: 105653646

Download BER/DEC Certificate

CO2 Emissions Indicator: 53.86 (kgCO₂/m²/yr)

MPRN: [Redacted]

Download Advisory Report

Dwelling Type: Mid-terrace house

Year of Construction: 1935

Floor Area: 146.792 (m²)

Trusted Partner API

```
},  
  "dateOfIssue": "2010-1222T15:14:58.303",  
  "deapVersion": "4.1.0",  
  "berNumber": "XXXXXX119",  
  "mprn": "XXXXXXXX7426",  
  "berRating": "F",  
  "energyValue": 420.83,  
  "co2Emissions": 5824.6869305592  
  "dwellingTypeld": 7,  
  "dwellingType": "Mid-terrace house",  
  "yearOfConstruction": "1930-07-25",  
  "floorArea": 80.6  
}
```

NAS Trusted Partner API Opportunities and Benefits



Access

The API facilitates easy access to BER data, enabling service providers to offer more accurate and tailored energy efficiency advice

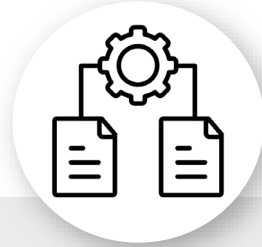

Integration

It supports the integration of technology solutions, enhancing the OSS customer Journey e.g. document generation



Trust

Trusted Partners gain credibility and trust with homeowners, as they are presenting real time SEAI BER Data

NAS Trusted Partner API Design

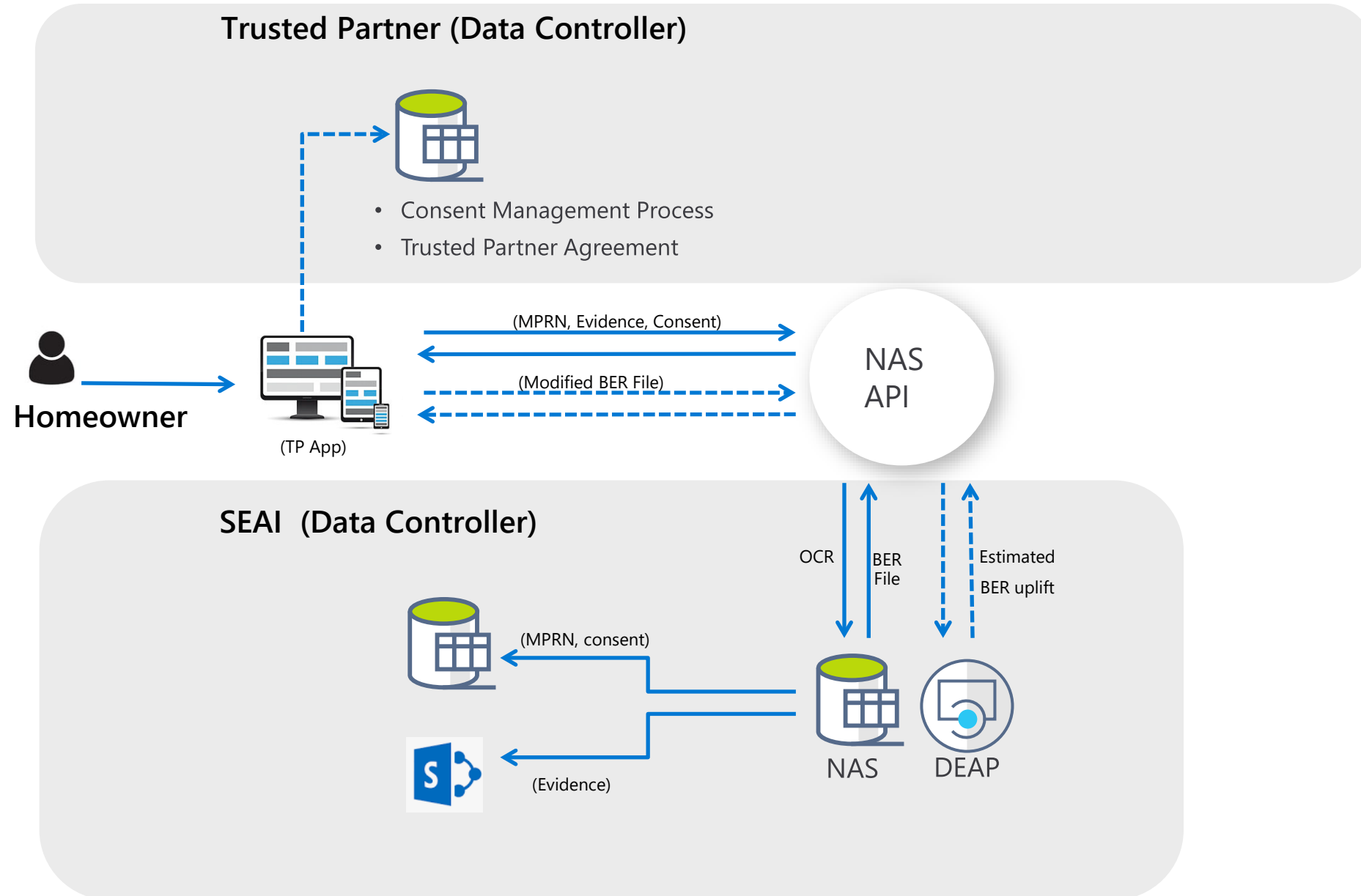

NAS Trusted Partner API Trial Analysis

Calls overtime



Calls overtime

● API Calls ● Pre-Consent API Endpoint

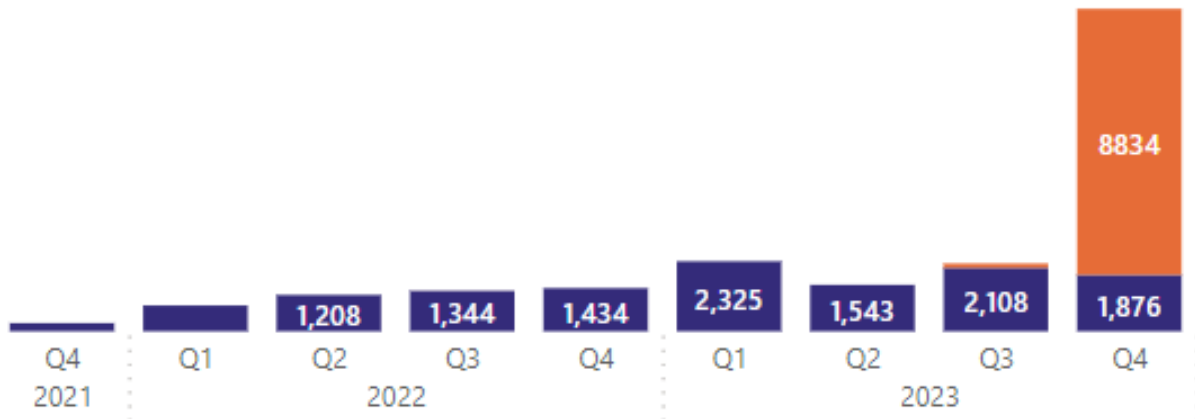

- A total usage of the service is 2,927,581 individual API Calls.

- A clear increase in the usage of BER file endpoint can be seen Year over Year from 2021 – 2023.

Primary Endpoints

EndPoint	Grand Totals
GetBerDataFile	20,367
CalculateTotals	2,878,376

Other Endpoints

EndPoint	Grand Totals
CheckMprnInDatabase	18,600
GetBerDataPreConsent	10,238

NAS Trusted Partner API Trial Analysis – GetBerDataFile

Calls overtime

● API Calls ● Distinct API Calls

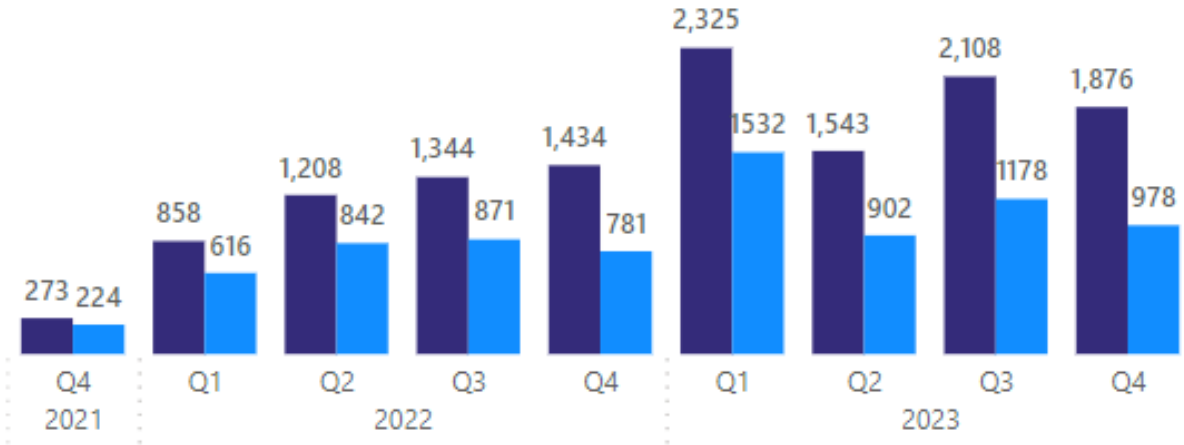

BER File API calls Q4 2021 – Q4 2023

BER File Endpoint	Grand Totals
API Calls	12969
Distinct MPRN API Calls	7933

Number of Applications

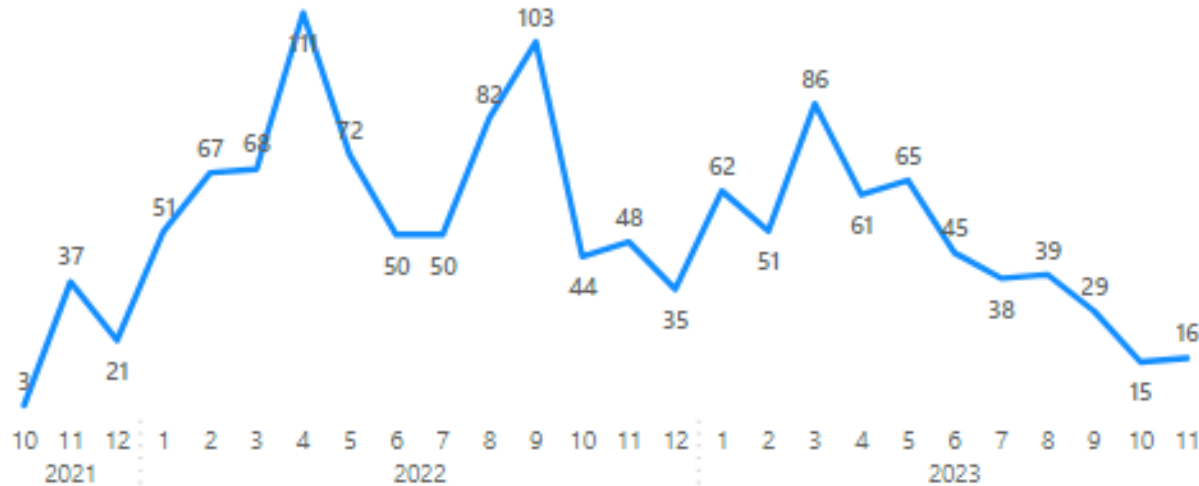

Applications from BER File API calls Q4 2021 – Q4 2023

BER File Endpoint	Grand Totals
MPRN's with Applications	1327
Average Time to Convert	177 days

NAS Trusted Partner API Trial Analysis – GetBerDataFile

Calls overtime

● API Calls ● Distinct API Calls

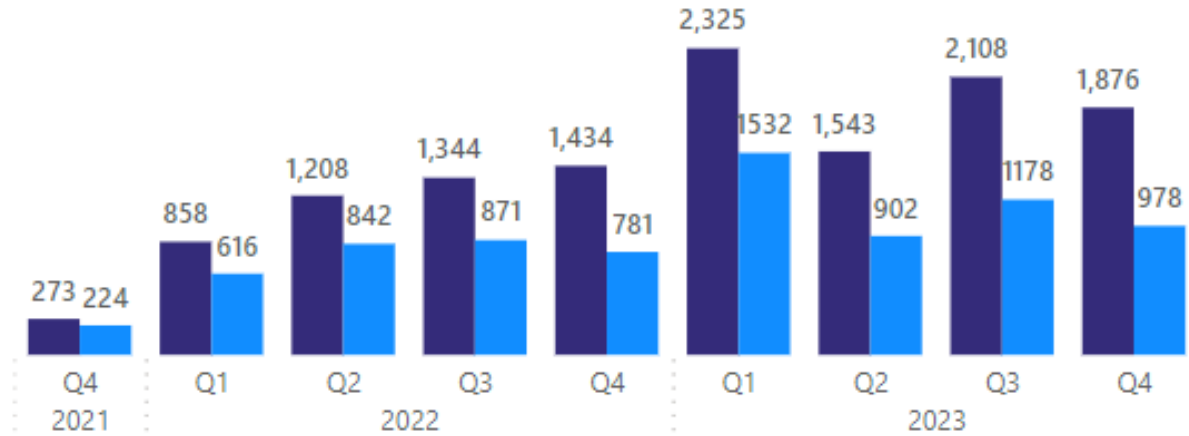

Forecast vs Actual Applications

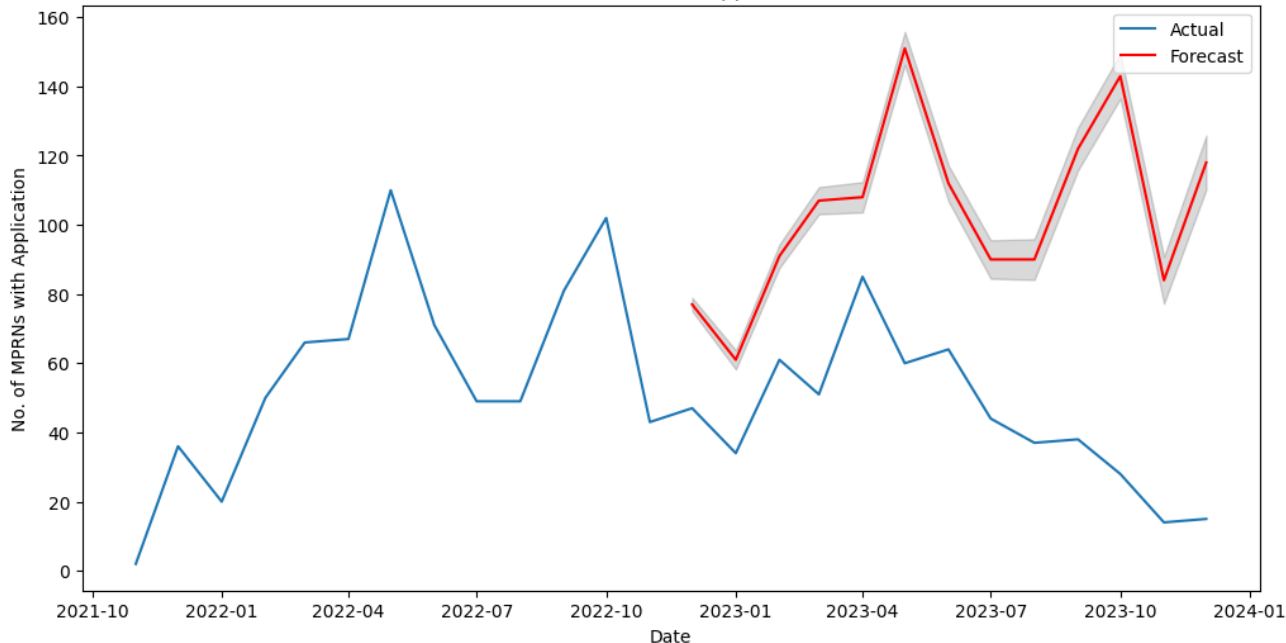

BER File API calls Q4 2021 – Q4 2023

BER File Endpoint	Grand Totals
API Calls	12969
Distinct MPRN API Calls	7933

Expected Applications from Q4 2021 – Q4 2023

BER File Endpoint	Grand Totals
MPRN with Applications (Full Trial)	1327
Expected Applications	2325

API Usage 2024 forecast (SARIMA model)

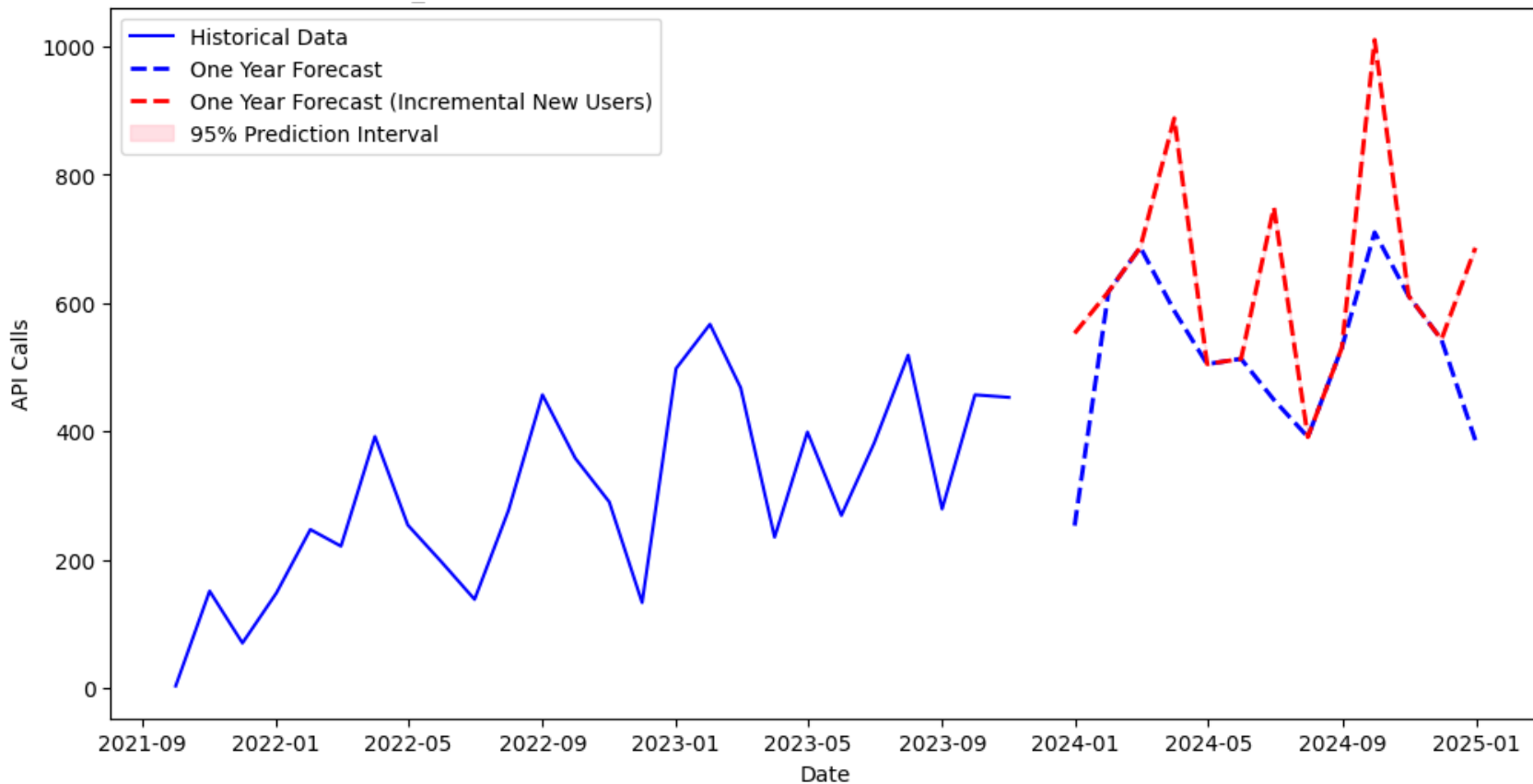

BER File API calls

Year	API Calls (Distinct MPRN)
2021	224
2022	3111
2023	4598
2024 Forecast	6532
2024 Forecast (with new TP)	8285

Projects

- Trusted Partner Full Service
- Release of IT Updates (Move to Azure)
- Tracking and co-creation of datasets

NAS Trusted Partner API

How to become a Trusted Partner

Fulfil the 5 requirements listed on the website

- <https://www.seai.ie/pilot-projects/>