



Non Domestic BER Assessors – Technical Bulletin

Issue No. 1/11

October 2011*

Contents:

1	Introduction.....	2
2	Quality Assurance programme.....	2
3	Building Energy Rating requirement	3
4	Data integrity.....	4
5	Choosing the correct property address	6
6	iSBEM software: correct data entry	7
7	Shell and Core buildings	9
8	Display windows and lighting	9
9	Use of alternate software.....	10
10	Non-domestic BER examination.....	10

The Non-domestic BER Technical Bulletins will be archived [here](#).

* The text on Shell and Core Buildings in this technical bulletin was withdrawn on October 2012. As of October 2012, Shell and Core buildings are only considered to be new-provisional ratings if the BER is published on the basis of plans/specs for a proposed construction. If a Shell and Core Building has been constructed already, a New-Final or Existing building BER applies. See October 2012 technical bulletin for updated guidance on Shell and Core Buildings.

1 Introduction

NEAP is the official procedure for the calculation of energy performance of non domestic buildings in Ireland for the purposes of producing Building Energy Ratings (BER).

The aim of this document is to address frequent queries and to provide clarifications to non-domestic Assessors in relation to the Non-domestic Energy Assessment Procedure (NEAP). Several non-domestic technical bulletins will be published annually.

SEAI published the NEAP Survey Guide and Survey Form in August 2011, giving general guidance on carrying out surveys for new-final and existing BERs. The documents can be downloaded from the following links:

- [NEAP Survey Guide](#)
- [NEAP Survey Form](#)

The survey guide should be read in conjunction with the following documents

- [SBEM User Guide](#)
- [SBEM Technical Manual](#)
- [BER Assessors Code of Practice](#)
- [Non Domestic Building Services Compliance Guide](#)

In addition to this, a number of frequently asked questions are covered under the [BER FAQ](#). Information required on Building Regulations Part L (current or previous) can generally be found under <http://www.environ.ie/en/TGD>.

2 Quality Assurance programme

The quality of service delivery by BER Assessors is central to the reputation and effectiveness of the BER scheme, both for the purposes of fulfilling legal obligations to building owners and in stimulating action to improve the energy performance of buildings. That quality of service has two key dimensions: competence and conduct.

As the Issuing Authority responsible for the BER scheme, and as part of an overall suite of provisions governing the registration and performance of BER Assessors, SEAI has in place a quality assurance system for BER Assessors, and a related disciplinary procedure. Through this system and procedure, SEAI maintains a strong focus on monitoring the technical performance and professional conduct of BER Assessors, and taking appropriate corrective action. This policy is designed to serve the interests of clients for BER services and of all reputable BER Assessors along with the integrity of the BER scheme.

The [Quality Assurance system and The Disciplinary Procedure](#), effective since the 1st May 2010, outlines the key elements and processes of the Quality Assurance System and of the Disciplinary Procedure for BER Assessors. It applies equally to BER Assessors operating in either the domestic or non-domestic buildings sector. Disciplinary sanction can arise from audits or complaints. Audits can be selected on either a random or targeted basis at SEAI's discretion.

Audit Selection:

As stated in Section 15 (Monitoring and Compliance) of the Code of Practice, SEAI shall not be required to show cause for the selection of any BER assessment or BER Assessor for audit and where a particular BER assessment or BER Assessor is selected for audit, no implication shall be drawn that SEAI has cause for concern about the accuracy of that BER assessment or of the integrity or competence of the relevant BER Assessor or principal.

Audit Process

Auditing is a key tool through which quality control of BER Assessors is implemented. The aim of the BER audit programme is to identify technical, procedural or system faults in a timely manner so that:

- Any errors identified can be corrected or other appropriate action taken in relation to published assessments;
- Such faults are avoided in future through feedback directly to the BER Assessor concerned and to other BER Assessors as appropriate through the relevant communication channels; and
- Such faults are avoided in future through disciplinary action as appropriate.

It is required that a BER Assessor responds to SEAL within 28 days from the issuing of notification of an audit request. It is important that Assessors carefully review an audit request which is sent to the Assessor registered email address as failure to respond to an audit request results in penalty points.

Audit Findings:

The primary objective of the BER Quality Assurance System is to monitor and ensure widespread operational compliance by BER Assessors with the Code of Practice and the relevant technical methodology. The system will help to assist BER Assessors in the effective discharge of their duties and to ensure the accuracy of assessments. The following are the most common findings:

Issue	Examples of errors and further guidance
No response to the audit request by the required deadline.	Each audit request will be issued along with a deadline date. Assessors must respond to the request for audit data by the deadline date.
Unacceptable information provided in support of Lighting Types.	Guidance on the lighting types can be found in the iSBEM manual. The NEAP Survey Guide provides guidance on acceptable evidence when entering non default or default data.
Unacceptable information provided in support of Efficiency of Heating System	The iSBEM manual and the Non Domestic Building Services Compliance Guide provide details of the relevant standards and details as to how the seasonal efficiency is calculated. The NEAP Survey Guide provides guidance on acceptable evidence when entering non default or default data.
No allowance for hot water storage in boiler heating systems	Typically boilers serve a hot water storage cylinder to provide hot water. The iSBEM manual gives guidance as to how to allow for hot water storage.

3 Building Energy Rating requirement

A Building Energy Rating is required under the following circumstances:

- 1) When a new or existing building is offered for sale (or let) a BER certificate must be produced by the vendor or their agent (e.g. auctioneer, estate agent or solicitor) to potential buyers or tenants.
 - 2) When a new building is offered for sale "off plans" a provisional BER certificate must be produced by the vendor to potential buyers or tenants, based on the pre-construction plans; and when the same new building is completed, a BER certificate must be supplied to the purchaser, based on a survey of the buildings as constructed (to take account of any design changes during construction).
 - 3) When a new building is built for a specific owner-occupier: A BER certificate must be procured by the person commissioning the building, prior to taking up occupation of the building.
 - ~~4) When a new or existing building is offered for lease as a Shell and Core building, a provisional BER certificate must be produced by the vendor to potential buyers or tenants, based on the pre-construction plans; and when the same new building is completed, a BER certificate must be supplied to the purchaser, based on a survey of the buildings as constructed (to take account of any design changes during construction).~~
- WITHDRAWN: OCTOBER 2012** ~~k has been completed that is specific to a tenant a final BER certificate must be provided.~~

4 Data integrity

A BER Assessor is responsible for ensuring that the data file (XML file) submitted to the Non Domestic NAS database is accurate and correct. All documentation supporting a BER must be secured prior to the publication of a rating and must be maintained on file. The documents listed in Section 1 above should be reference in ensuring compliance with both the Code of Practice and the NEAP methodology.

Assessors should note that when changes are made in an assessment, “Calculate BER” on the “Ratings” screen should be selected to update the results and XML file when using iSBEM. Please refer to the following example for further details:

Example

(i) Administration Details

Confirm that the administration details contained within the XML file match those inputted into the software. For example the following is the input in the iSBEM software:

The screenshot displays the iSBEM v3.5.b software interface. The title bar reads "iSBEM v3.5.b - General - Blogs Café". The main menu includes "General", "Project Database", "Ratings", "Building Navigation", and "About iSBEM". The "General Information" tab is selected, showing "Basic information about Project, Owner and Energy Assessor". The "Building details" sub-tab is active, containing the following fields:

Building type	Retail
Name of the project	Blogs Café
MPRN	012345678910
Building address	1 Main St
County	Dublin 1
Location Description	Café Unit
Year of Construction	2002

A checkbox labeled "Tick if the building is of special conservation status." is present and unchecked.

Which is shown under the Report Header, Property Details and Property Address in the XML file:



```

- <!-- This XML message is for the Republic of Ireland -->
<?xml version="1.0" ?>
<Report>
  <Report-Header>
    <Project-Name>Blogs Café</Project-Name>
    <Issue-Date>2011-09-14</Issue-Date>
    <Report-Type>1</Report-Type>
    <Valid-Until>2021-09-13</Valid-Until>
    <Inspection-Date>2011-09-13</Inspection-Date>
    <Registration-Date>2011-09-14</Registration-Date>
    <Status>entered</Status>
  </Report-Header>
  <Energy-Assessor>
    <Assessor-Number>123456</Assessor-Number>
    <Name>A Another</Name>
    <Telephone>01 1234567</Telephone>
    <Address>2 Main Street</Address>
    <County>Dublin</County>
    <Accreditation-Scheme-Name>SEI Interim AS</Accreditation-Scheme-Name>
    <Qualifications>NOS4</Qualifications>
    <Trading-Address>2 Main Street</Trading-Address>
    <Company-Name>A Another Ltd</Company-Name>
    <Company-Number>123457</Company-Number>
    <Status>Registered</Status>
  </Energy-Assessor>
  <Property-Details>
    <Location-Description>Café Unit</Location-Description>
    <UPRN>012345678910</UPRN>
  </Property-Details>
  <Property-Address>
    <Address-Line-1>1 Main St</Address-Line-1>
    <Address-Line-2 />
    <Address-Line-3 />
    <Address-Line-4 />
    <County>Dublin 1</County>
  </Property-Address>

```

(ii) Results

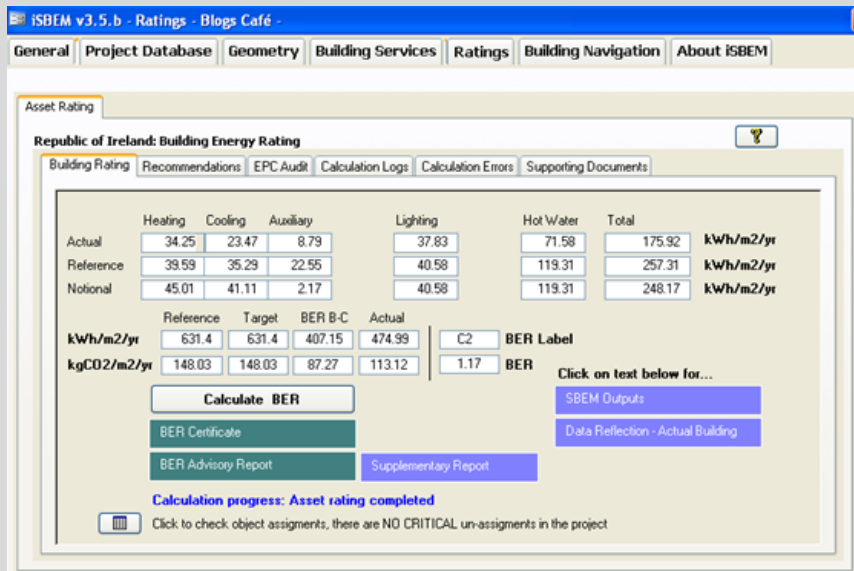
Confirm that the results in the XML file are as detailed in the software. For example the results of an assessment are as follows:



The energy details for the actual, reference and notional buildings can be verified under “Global Performance” under each building within the XML. Below shows the details for the actual building:

```

- <Global-Performance>
  <KWH-M2-Heating>34.2455</KWH-M2-Heating>
  <KWH-M2-Cooling>23.4743</KWH-M2-Cooling>
  <KWH-M2-Auxiliary>8.78843</KWH-M2-Auxiliary>
  <KWH-M2-Lighting>37.8313</KWH-M2-Lighting>
  <KWH-M2-DHW>71.5842</KWH-M2-DHW>
  <KWH-M2-Equipment>101.496</KWH-M2-Equipment>
  <KWH-M2-Natural-Gas>0</KWH-M2-Natural-Gas>
  <KWH-M2-LPG>0</KWH-M2-LPG>
  <KWH-M2-Biogas>0</KWH-M2-Biogas>
  <KWH-M2-Oil>0</KWH-M2-Oil>
  <KWH-M2-Coal>0</KWH-M2-Coal>
  <KWH-M2-Anthracite>0</KWH-M2-Anthracite>
  <KWH-M2-Smokeless>0</KWH-M2-Smokeless>
  <KWH-M2-Dual-Fuel>0</KWH-M2-Dual-Fuel>
  <KWH-M2-Biomass>0</KWH-M2-Biomass>
  <KWH-M2-Supplied>175.923</KWH-M2-Supplied>
  <KWH-M2-Waste-Heat>0</KWH-M2-Waste-Heat>
  <KWH-M2-District-Heating>0</KWH-M2-District-Heating>
  <KWH-M2-Displaced>0</KWH-M2-Displaced>
  <KWH-M2-PVS>0</KWH-M2-PVS>
  <KWH-M2-Wind>0</KWH-M2-Wind>
  <KWH-M2-CHP>0</KWH-M2-CHP>
  <KWH-M2-SES>0</KWH-M2-SES>
</Global-Performance>

```

Also the BER certificate details can be verified under “Building Energy Rating Certificate” in the XML, below shows the details for this example:

```

- <Building-Energy-Rating-Certificate>
  - <Building-Energy-Rating>
    <BER>1.17</BER>
    <BER-Grade>C2</BER-Grade>
    <Primary-Energy>474.99</Primary-Energy>
    <CO2-Indicator>1.3</CO2-Indicator>
    <CO2-Emissions>113.12</CO2-Emissions>
    <PartL-Primary-Energy-Pass>Yes</PartL-Primary-Energy-Pass>
    <PartL-CO2-Pass>Yes</PartL-CO2-Pass>
  </Building-Energy-Rating>

```

5 Choosing the correct property address

It is critical that BER Assessors ensure that they have the correct postal address for the building that is being rated and that they publish the rating under this address.

The address should allow for unique identification of the property in so far as possible, and in such a way that prospective purchasers or renters (or their agents) can content themselves that the rating before them in fact relates to the property in question. Any ambiguity in addresses should be eliminated or Assessors run the risk that a rating will be revoked and will thereafter need to be republished with a satisfactory address.

Assessors should confirm the postal address with the building owner. In addition there are a number of tools available to assist Assessors in verifying the postal address, as outlined below.

1. Meter Point Reference Number (MPRN)

The Meter Point Reference Number (MPRN) is a unique reference allocated to the building by the utility supplier and can be found on the electricity bill. The NDNAS enables assessors to confirm the correct building address through the utility supplier’s database of MPRNs. Occasionally there may be an issue with the address stored in the MPRN database. For example, in the case of new developments the address given to the utility supplier may be the address used during the construction phase and may be out of date. The assessor must publish the rating under the most accurate address.

2. Other Utility Bills

Other utility bills, such as gas bills, can be another useful reference point.

3. An Post: <http://address.anpost.ie/precisionaddressanpost/precisionaddresspost.aspx>

An Post provide an address verification service. The maximum number of searches allowed is 10 per day or 80 per month. If you require more searches per month then you need to contact info@dataireland.ie. The address is verified by checking the details you provide against Ireland’s official address database, the Irish GeoDirectory.

4. GeoDirectory: <http://www.geodirectory.ie/GeodirectoryMap.aspx>

The GeoDirectory is a database (a joint An Post and Ordnance Survey initiative) that contains the address and map coordinates of over 1.7 Million addresses, every building in the Republic of Ireland. The database is updated by An Post postal workers, with official updates released on a quarterly basis. GeoDirectory offer services such as GeoAddress Locator which could be used to confirm building addresses.

5. Bizmaps: <http://www.bizmaps.ie/>

Bizmaps offer a service called Address Link which is an address matching software tool that matches addresses to the GeoDirectory.

6 iSBEM software: correct data entry

iSBEM is a free user interface for the Simplified Building Energy Model (SBEM) , the default software for the “Non Domestic Energy Assessment Procedure”. BER Assessors are responsible for ensuring that the data inputted is an accurate representation of all characteristics relevant to the energy performance of the building. It is not possible for the software to highlight all potential errors or omissions. The following are examples of typical errors:

Example

(i) The efficiency of the heating and cooling should be inputted as a fraction and not a percentage. A boiler with a heating seasonal efficiency of 85% should be entered as 0.85:



The screenshot shows the 'Heating system' tab in the iSBEM software. The 'Heat source' is set to 'LTHW boiler' and 'Fuel type' is 'Natural Gas'. The 'Do you know the effective heat generating seasonal efficiency?' section has 'Yes, seasonal efficiency is' selected with a value of 0.85 entered in the text box. A red checkmark is placed to the left of this section.



The screenshot shows the same 'Heating system' tab in the iSBEM software. In the 'Do you know the effective heat generating seasonal efficiency?' section, 'Yes, seasonal efficiency is' is selected with a value of 85 entered in the text box. A red X is placed to the left of this section.

(ii) Default Efficiency for Hot Water Heaters served by Grid Electricity.

When “Stand Alone Water Heater” or “Instantaneous Hot Water Only” are selected for the hot water heater the defaults are 0.7 and 0.65 respectively for non-electric fuel supplies. When electricity is selected as the fuel type the efficiency should be entered as 1:

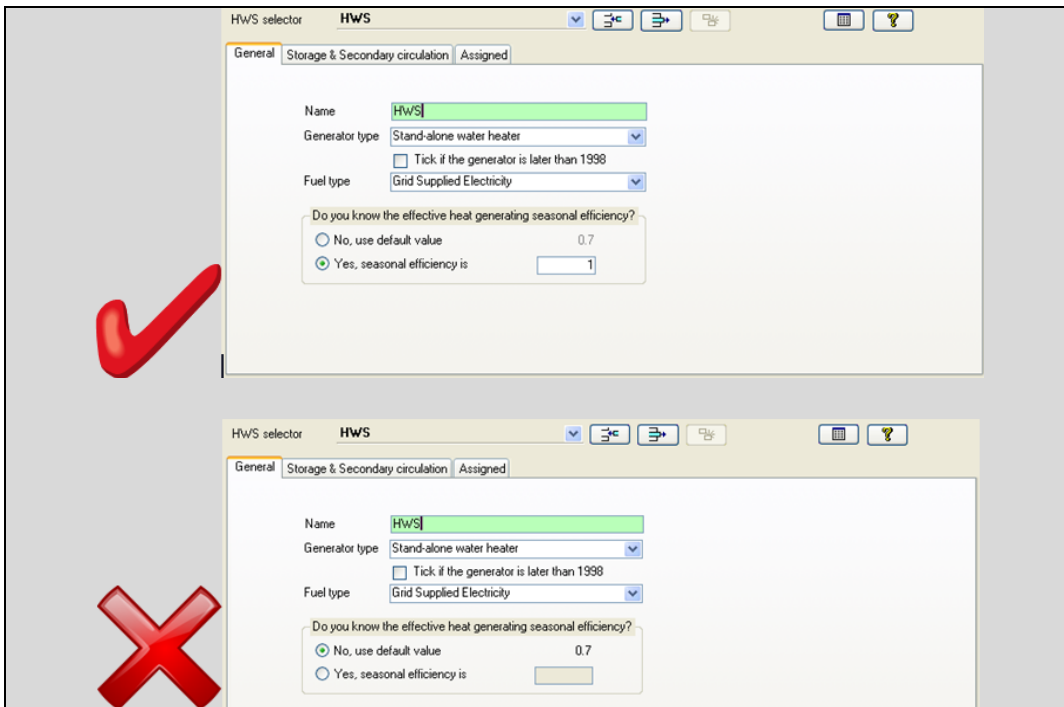

(iii) Project Database

When a new construction is created, a U-value and K_m value are automatically applied based on the data selected in the iSBEM library. When assessors select “Introduce my own values” these values are automatically applied. It is the responsibility of the assessor to ensure that the values used under “Introduce my own values” are accurate and correct and that documentary evidence is available to support entries.

Example of new wall construction being created, U-value and K_m value automatically applied:

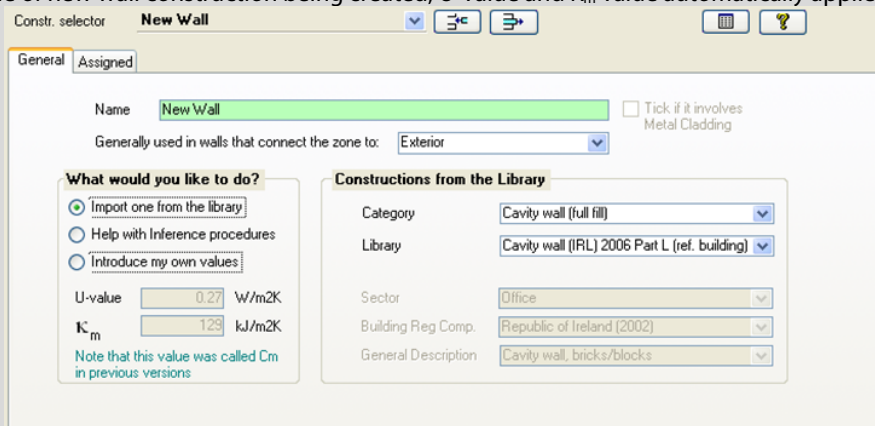

Example showing selection of “Introduce my own values” which automatically applies the previously selected defaults but requires proof of the non-default values subsequently entered.

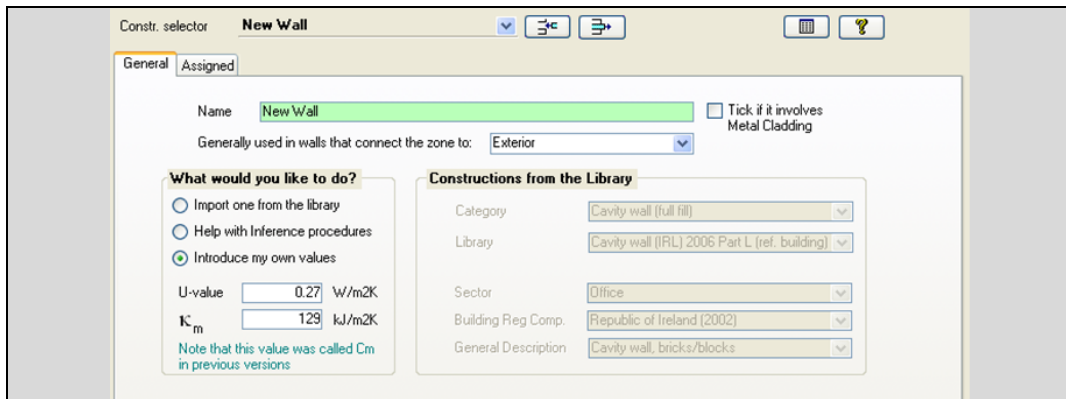

7 Shell and Core buildings

For shell and core buildings, services will be provided (especially mechanical ventilation and cooling) at the time the building is let. Buildings of this type that are let or sold as bare structures, or as services, will not require a National Building Energy Rating (BER) as the expectation is that the building will be used to maintain the indoor climate. For further details, refer to NEA's guidance.

For new buildings, the first fit-out is a New Final BER and must be produced in compliance with the Building Regulations.

For all buildings, if there is any material in the building fabric, services for heating, hot water, ventilation and cooling, then the BER certificate is no longer valid and a BER certificate is provided under the circumstances outlined in Section three of the Regulations.

If a building owner leases a shell and core building and the tenant arranges for the fit-out of the building, the BER upon the lease was made is to be valid. However there is no requirement for the tenant to produce a new BER on the fit-out as the building is not being put for sale or re-let.

If a building owner arranges a fit-out of a building prior to commencement of a lease, then the building owner is responsible for producing a new BER based on the building fit-out.

8 Display windows and lighting

Display windows and lighting may be found in the following building types:

1. Shops: Including retail-warehouse, undertakers, showrooms, post offices, hairdressers, shops for sale of food for consumption off premises;
2. Financial and professional services: banks, building societies, estate and employment agencies, betting offices;
3. Food and drink: restaurants, pubs, wine bars;
4. Assembly and Leisure; cinemas, concert halls, sports and leisure uses.

The definition for each is as follows:

Display Window:

This is an area of glazing intended for the display of products or services on offer within the building, positioned:

- At external perimeter of the building; and
- At an access level and immediately adjacent to a pedestrian thoroughfare.

There should be no permanent workspace within one glazing height of the perimeter. Glazing more than 3m above such an access level should not be considered part of the display window except:

- Where the products on display require a greater height of glazing;
- In cases of building work involving changes to the façade and glazing requiring planning consent, where planners should have discretion to require a greater height of glazing; eg to fit in with surrounding buildings or to match the character of the existing façade.

Display Lighting:

This is the lighting intended to highlight displays of exhibits or merchandise, or lighting used in spaces for public leisure and entertainment such as dance halls, auditoria, conference halls, restaurants and cinemas.

9 Use of alternate software

The NEAP procedure allows for the use of approved software packages as an alternate to the default, Simplified Building Energy Model.

Currently there are a number of approved software packages that provide a Front-end Interface for the Simplified Building Energy Model. A list of approved software can be found here: [Approved Software](#).

Assessors who have been accredited to use alternate software should note the following:

1. Non defaults should be used where possible, however where these cannot be substantiated default values must be used. The default values to be used are as outlined in the iSBEM User Guide, iSBEM software and the NEAP survey guide. It is the responsibility of the assessor to ensure that any defaults used in alternate software comply with the iSBEM software and aforementioned documents. Third party software does not necessarily use or provide the same defaults as iSBEM.
2. In all cases, the methodology outlined in the iSBEM user guide, and NEAP Survey Guide takes precedence over guidance from third party software.

10 Non-domestic BER examination

The non-domestic BER examination is scheduled for introduction in November 2011. All registered BER Assessors will be required to pass the non-domestic BER examination. Further details will be published on www.seai.ie/ber.



Non Domestic BER Assessors – Technical Bulletin

Issue No. 1/12

January 2012

Contents:

1	Building Services – HWS – Multi Tenant Premises.....	2
2	General - Building Type.....	3
3	Geometry - Zone Heights – Measurement Convention.....	6
4	Geometry – Zone Heights – Default Slab Thickness.....	7
5	Geometry – Global Zone Height	8
6	Building Services – Zones - Lighting	9
7	Data Integrity for a Provisional BER	9
8	iSBEM software: Updating Project Files	10
9	Quality Assurance – Quality of Photographic Evidence.....	12

The Non-domestic BER Technical Bulletins are archived [here](#).

This technical bulletin will address a number of queries recently encountered by the BER audit team and Helpdesk, including:

- Hot Water Systems in Multi Tenant Premises
- Building Type classification;
- Clarification of Zone Heights;
- Clarification of Zone Lighting Characteristics;
- Data Integrity for Provisional BERs.
- Updates in iSBEM software
- Photographic evidence for BERs

1 Building Services – HWS – Multi Tenant Premises

When assessing a property of a tenant or occupant in a multi-tenant premises, Assessors should consider the following guidance on treatment of hot water services.

HWS Supplied by Landlord or from a Central Water Heating System

Where the hot water services are supplied to each tenant by a central water heating system (e.g. from the landlord to the tenant's premises) the efficiency and storage volume should be based on the details of that central system. Where this information is not available default data should be used.

Example

Below shows an example of a building where a BER assessor is carrying out a BER assessment for Tenant 3.

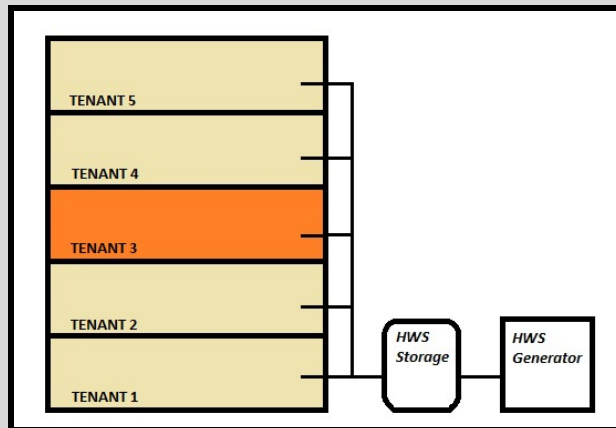

(i) Tenant 3 has the same Building Activities as the remainder of the tenants:

The HWS storage for Tenant 3 BER assessment should be based on the following:

$$\text{Total Central HWS Storage} \times \frac{\text{Floor Area of Tenant 3}}{\Sigma \text{Floor Area of Tenants 1,2,3,4,5}}$$

The efficiency of the HWS generator for Tenant 3 BER assessment should be based on the central HWS generator.

(ii) Tenant 3 has different Building Activities to the remainder of the tenants:

The HWS storage for Tenant 3 BER assessment should be apportioned based on recognised methodologies such as CIBSE guidelines for Hot Water Storage.

The efficiency of the HWS generator for Tenant 3 BER assessment should be based on the landlord HWS generator.

HWS Supplied by Tenant

Where the hot water services are part of the tenant’s system the efficiency and storage volume should be based on the details of the tenants services. Where this information is not available default data should be used.

Example

Below shows an example of a building where a BER assessor is carrying out a BER assessment for Tenant 3.

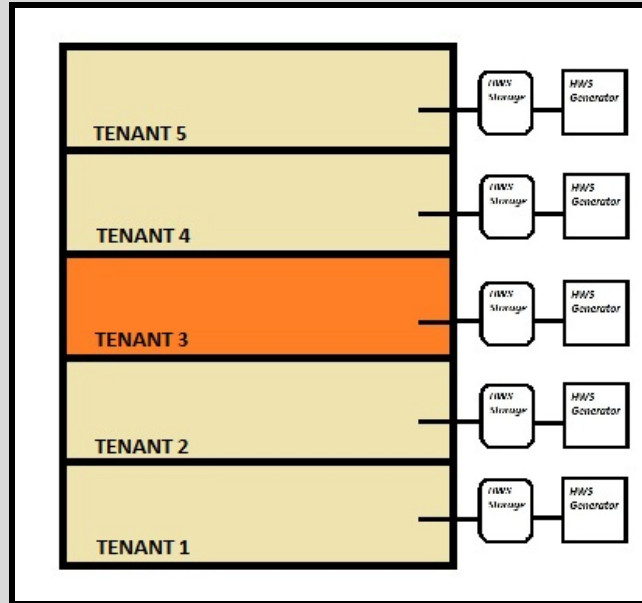

The HWS storage for Tenant 3 BER assessment is based on the actual storage volume.
 The HWS Generator Efficiency for Tenant 3 BER assessment is based on the efficiency of the HWS Generator.

2 General - Building Type

We have found in some recent audits that BER assessors have not correctly identified the building type, particularly in reference to “retail” buildings. An example would be an audit where an assessor was carrying out a BER assessment for an Estate Agent, and selected “Office” as the building type, however as detailed below the correct building type would be “Retail”.

A BER assessor is responsible for ensuring that the correct Building Type is selected for the assessment.

The Building Type sets the activities that may be assigned to the zones. Assessors should refer to Appendix F of the SBEM User Guide for a list of activities associated with the building types.

The Building Type selected under General Information – Building Details is the building type that defines the majority of the building and this will be displayed on the BER certificate.

Here is the list of Building Types available in the NEAP software. This list closely aligns with the UK Town and Country Planning Use Classes.

	Building Type	Description
1	Airport Terminals	Airport Terminal
2	Bus Station/ Train Station/ Seaport Terminal	Bus/ Train and Seaport Terminal
3	Community/ Day Centre	Creches, day nurseries and day centres

Non Domestic BER Assessors –Technical Bulletin January 2012

4	Crown and County Courts	Law Courts
5	Dwelling	Residential spaces within Non Domestic buildings not designed or altered for use as a separate dwelling.
6	Emergency Services	Emergency Services includes Fire Stations.
7	Further Education Universities	Universities
8	Hospital	Hospitals
9	Hotel	Hotels, boarding and guest houses where no significant element of care is provided.
10	Industrial Process Building	Use for carrying on an industrial process, it excludes light industry appropriate in a residential area.
11	Laundrette	Laundrette
12	Libraries/ Museums/ Galleries	Art Galleries, museums and libraries
13	Miscellaneous 24hr activities	Miscellaneous 24hr activities.
14	Nursing Residential Homes and Hostels	Residential care homes and nursing homes
15	Office	Office
16	Primary Health Care Buildings	Non residential clinics and health centres
17	Primary School	Primary School.
18	Prisons	Secure residential accommodation, including use as a prison, young offenders institution, detention centre, short term holding centre and secure hospital.
19	Restaurant/ Public House	For the sale of food and drink for consumption on the premises – restaurants, snack bars, cafes, public houses and wine bars
20	Retail	Shops, hairdressers, undertakers, travel and ticket agencies, post offices, pet shops, sandwich bars, showrooms, domestic hire shops, dry cleaners, funeral directors, banks, building societies, estate and employment agencies. Also professional and financial services and betting offices where the services are provided principally to visiting members of the public.
21	Retail Warehouse	Retail Warehouse.
22	Secondary School	Secondary School
23	Social Clubs	Bingo and Dance Halls
24	Sports Centre/ Leisure Centre	Swimming pools, skating rinks, gymnasiums.
25	Sports Ground Arena	Sports Arena
26	Telephone Exchanges	Telephone Exchange.
27	Theatres/ Cinemas/ Music Halls and Auditoria	Cinemas, music and concert halls, night clubs and theatres.
28	Warehouse and Storage	Use as a storage or distribution centre
29	Workshops/ Maintenance Depot	Research and Development of products, light industry appropriate to being a use which can be carried out in any residential area without detriment to the amenity of that area by reason of noise, vibration, smell, fumes, soot, ash, dust or grit.

The following shows an example of how to treat a mixed use building;

Mixed Use Building Type	
<p>This example shows a new building with speculative office space on levels 1 to 4 totalling an area of 4000m², and speculative retail space contained on the ground floor totalling 1000m².</p>	
<p>In this case the Main Building Type is "Office" as it defines the majority of the building. The BER certificate shall show the building type as "Office".</p>	
<p>For the office zones, Z1/01, Z2/01, Z3/01 and Z4/01 the building type remains as "Office" and the activity is selected based on activities associated with that building type. In this zone the activity chosen is "Speculative Office Space".</p>	
<p>For the retail zones, Z0/01 and Z0/02 the activities associated with building type "Office" are not appropriate. Therefore the building type for these zones is changed to "Retail" and appropriate activity selected. In this space the activity chosen is "Speculative Retail Space".</p>	

3 Geometry - Zone Heights – Measurement Convention

BER Assessors have asked the Helpdesk for guidance on deriving zone heights. This article describes a number of different cases. The following is the measurement convention for determining zone heights:

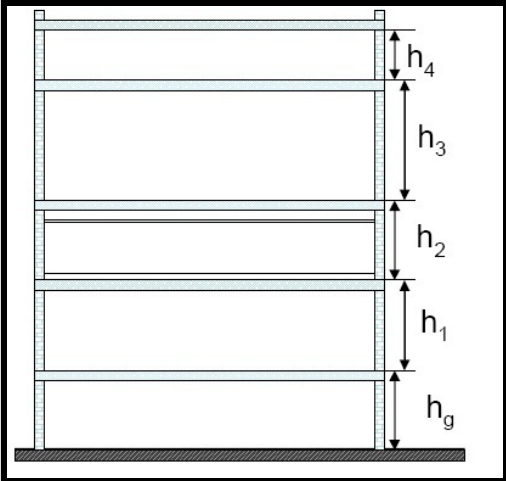
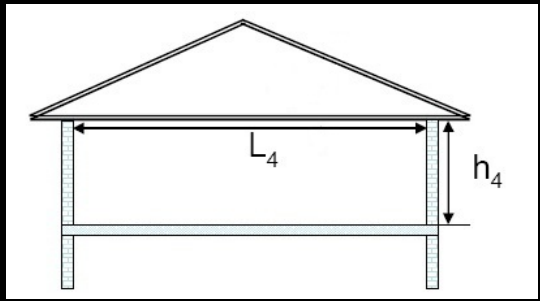
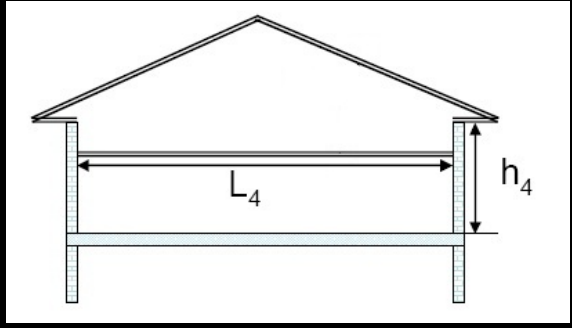
Zone Height and Element Areas	
<ul style="list-style-type: none"> • For ground and intermediate floors the zone height is from top of floor slab to top of floor slab. • For top floor the zone height is from top of floor slab to soffit/underside of roof slab • For the purpose of zone height and surrounding wall areas, suspended ceilings and raised floors are ignored. 	 <p>The diagram shows a cross-section of a building with five floors above ground. The ground level is indicated by a hatched area at the bottom. Vertical dimension lines on the right side of the building indicate the heights of different zones: h_g is the height from the ground to the top of the first floor slab; h_1 is the height from the top of the first floor slab to the top of the second floor slab; h_2 is the height from the top of the second floor slab to the top of the third floor slab; h_3 is the height from the top of the third floor slab to the top of the fourth floor slab; and h_4 is the height from the top of the fourth floor slab to the top of the fifth floor slab.</p>
<p>For top floors with pitched roof but flat ceiling:</p> <ul style="list-style-type: none"> • Zone height is top of floor to underside of soffit/eaves level - h_4 • Area of gable wall is that below soffit/eaves level i.e. $L_4 \times h_4$ 	 <p>The diagram shows a cross-section of a building with a pitched roof. The top floor has a flat ceiling. The zone height h_4 is measured from the top of the floor slab to the underside of the soffit/eaves level. The length of the gable wall below the soffit/eaves level is labeled L_4.</p>
<p>For top floors with pitched roof and dropped ceiling (with or without insulation at ceiling level):</p> <ul style="list-style-type: none"> • Zone height is top of floor to underside of soffit/eaves level - h_4 • Area of gable wall is that below soffit/eaves level i.e. $L_4 \times h_4$ 	 <p>The diagram shows a cross-section of a building with a pitched roof and a dropped ceiling. The zone height h_4 is measured from the top of the floor slab to the underside of the soffit/eaves level. The length of the gable wall below the soffit/eaves level is labeled L_4.</p>

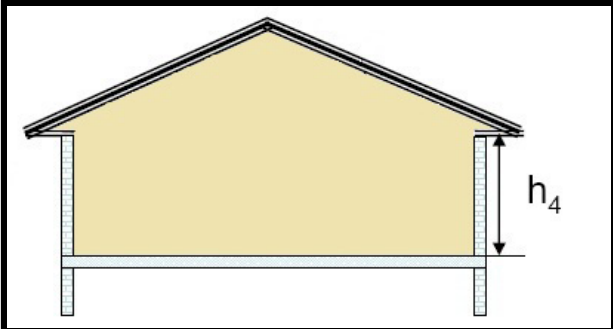
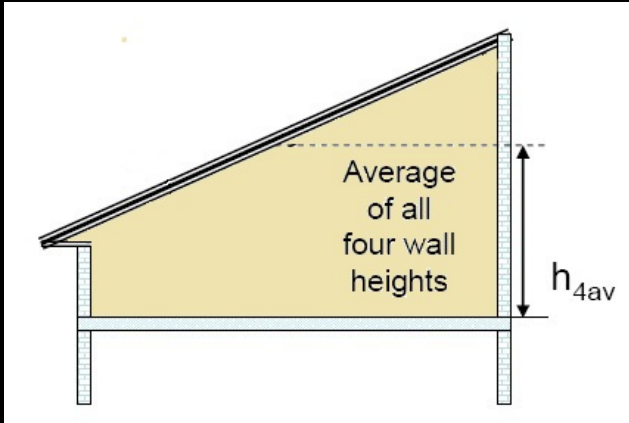
<p>For top floors with pitched ceiling:</p> <ul style="list-style-type: none"> • Zone height is top of floor to underside of soffit/eaves level - h_4 (not average room height) • Area of gable wall is whole wall up to roof apex (shaded area) 	
<p>For top floors with mono-pitched ceiling:</p> <ul style="list-style-type: none"> • Zone height is top of floor to weighted average height of all walls - h_{4av} • Area of gable wall is whole wall (shaded area) • Note that zoning for daylight areas must be carried out manually 	

4 Geometry – Zone Heights – Default Slab Thickness

In addition to the guidance above on zone heights, the slab thickness also needs to be considered. When there is insufficient proof of the actual slab thickness (not detailed in drawings for example), a default of 250mm may be used.

Ensure that where ceiling voids and raised floors exist that these are correctly identified. The depth of the ceiling voids and raised floors should be included in the overall height of the zone. Check that documentary evidence is maintained to support entry.

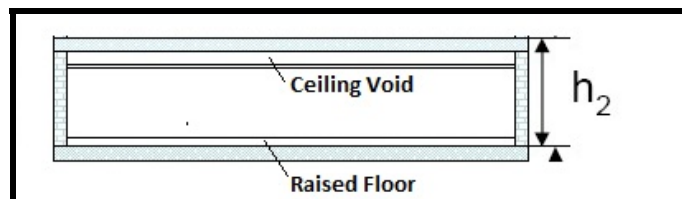

5 Geometry – Global Zone Height

As a result of feedback from audits, it was found that the global zone height was entered in error in some assessments. A global zone height can be set in iSBEM under General and Geometry, Building Details. The value entered by the Assessor will be given as the global or default zone height in each of the zones. The Assessor can alter the height or use the global height for respective zones.

Example

Below shows an example of a building.
 Z0/01, Z1/01 and Z2/01 have the same height - h_1
 Z0/02 has a different height - h_2

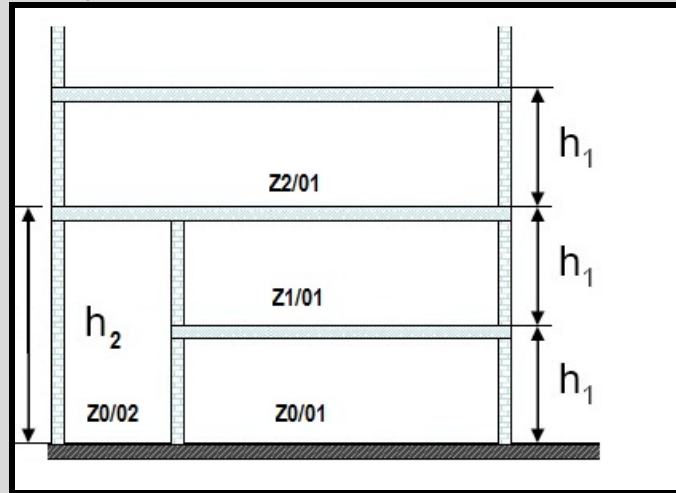

The Global zone height is set at h_1 :

General & geometry Global Thermal Bridges

Building infiltration (Global)

No, use default value 10 m³/h/m²

Yes, Air permeability at 50pa is 0 m³/h/m²

Building orientation

Building (clockwise) rotation 0 degrees

Section 6 (Scotland), Accredited Construction Details

Tick when building designed and built following Accredited Construction Details. (These details are primarily of use for domestic type construction)

Building details

Zone height (Global) m

Building area: m²

Currently total zone area is 2900 m²

Building volume

Let iSBEM calculate the volume of the building

Use my own value m³

For each of the zones the global/ default height is then h_1 , as evident in Z0/01:

General Quick Envelopes Envelope Summary

Name Multiplier

HVAC system

Building Type

Activity

Area m² Flr-to-flr height m

Where a zone height differs from the global/ default height, the BER assessor selects the global button G and enters the actual zone height. In this case Z0/02 has a different height therefore the zone is updated accordingly:

Name	<input type="text" value="z0/02"/>	Multiplier	<input type="text" value="1"/>
HVAC system	<input type="text" value="HVAC for the example building"/>		
Building Type	<input type="text" value="Office"/>		
Activity	<input type="text" value="Common room/staff room/lounge"/>		
Area	<input type="text" value="162"/> m2	Flr-to-flr height	<input type="checkbox"/> G <input type="checkbox"/> h2 m

6 Building Services – Zones - Lighting

The BER auditors have encountered assessments where BER assessors can identify a lighting type (for example the presence of fluorescent fittings) but are unable to correctly identify the specific lighting type (T12, T8 etc) within a zone. Where the specific fitting cannot be identified, take the most conservative (highest power density) option from Table 15 of the iSBEM User Guide.

For example, high bay fittings are used in a zone, the assessor can provide photographic evidence to demonstrate their presence. However the assessor is unable to determine whether the specific fitting is a High Pressure Sodium Fitting or a Metal Halide.

In this case, the assessor must obtain additional documentary evidence such as As Built drawings and specifications to identify the specific lamp type, however where these are not available the assessor should select the more conservative option; in this case the Metal Halide fitting.

7 Data Integrity for a Provisional BER

Section 5 of the BER Assessor's [Code of Practice](#), indicates that "a New Provisional BER assessment can be carried out by BER Assessors based on design drawings and specifications of an uncompleted building provided that, on completion of the building in question, a New Final BER assessment is carried out on the completed building".

The provisional BER must represent the specification and drawings of the building. The Assessor must verify each item entered in the provisional BER and in a similar manner to the final or existing BER must have documentary evidence to support all entries such as signed off specifications, U-value calculations and so on. Descriptions of acceptable documentary evidence are detailed in the non-domestic survey guide.

The specification and drawings must be provided by the client or their representatives, however where as part of their role within a project a BER Assessor has developed the specification or drawing, they must be signed off by the client confirming that the uncompleted building shall be built to the specifications and drawings produced by the Assessor.

The specification and drawings must provide adequate information to support an entry, please refer to examples below.

In exceptional cases, there may be insufficient documentary evidence to support an entry. The assessor may then use the default values. The default should be based on the relevant guidance documents and iSBEM defaults and the assessor should keep a record with the assessment detailing the reason for the default chosen.

As an example, the following provides guidance on the documentation required for a number of items.

Data Entry	Acceptable Supporting Documentation	Unacceptable Supporting Documentation
U-Value of Opaque Elements	<ul style="list-style-type: none"> - Specification/ Drawing detailing materials used in element construction and - U-Value Calculation and - Appropriate References to Thermal Conductivities used in U value calculation 	<ul style="list-style-type: none"> - Specification/ Drawing stating U value of element is X.XX
Pressure Test Results	<ul style="list-style-type: none"> - Specification/ Drawing stating Pressure Test shall achieve X m3/hm2/hr and - Drawings showing details of air barrier and addressing penetrations and junctions <p style="text-align: center;">Or</p> <p>Use expected values from ATTMA TSL2 Table under Section 2.1: Normal air permeability values (e.g. for a naturally ventilated office, assume 7.0 m3/m2/hr @50Pa)</p> <p>Permeability test must be carried out by individual with required accreditation (equivalent to NSAI air tightness testing scheme) on final building once construction is complete. This measured value is used in the final BER. If test not carried out on final building, then iSBEM defaults apply.</p>	<ul style="list-style-type: none"> - Specification/ Drawing stating Pressure Test shall achieve X m3/h/m2 with no other supporting data.
Thermal Bridging Factor	<ul style="list-style-type: none"> - Specification/ Drawing stating the building will conform with “Limiting Thermal Bridging and Air Infiltration - Acceptable Construction Details” and - For a provisional BER for a building that proposes to conform with “Limiting Thermal Bridging and Air Infiltration - Acceptable Construction Details” Assessor must provide the relevant drawings clearly showing the relevant details. These drawings should be signed off by the developer/builder, site engineer or architect confirming that the uncompleted building shall be built to these details. <p style="text-align: center;">Or</p> <p>Certified PSI values and associated drawings etc.</p>	<ul style="list-style-type: none"> - Specification/ Drawing stating the building will conform with “Limiting Thermal Bridging and Air Infiltration - Acceptable Construction Details” with no details provided. - Thermal bridging PSI values based on uncertified calculations
Heating System Efficiency	<ul style="list-style-type: none"> - Specification/ Drawing detailing proposed heating system and - Efficiency of Heating System based on relevant standards and - Calculation of Seasonal Efficiency based on Non Domestic Building Services Compliance Guide 	<ul style="list-style-type: none"> - Specification/ Drawing stating that the boiler efficiency shall be X%.

8 iSBEM software: Updating Project Files

BER assessors should be aware that when converting a project created in a previous version of the iSBEM software to a current version of the software, it is their responsibility to check that all input data is an accurate representation of the building.

Assessors should be aware that defaults may vary between software versions and the published assessment should be based on the defaults applicable at time of BER publication. The following provides one such example.

Example

The following shows a default wall element created in Version 3.5.a of the software:
The U value is 0.44 for the cast in-situ concrete construction from 1992.

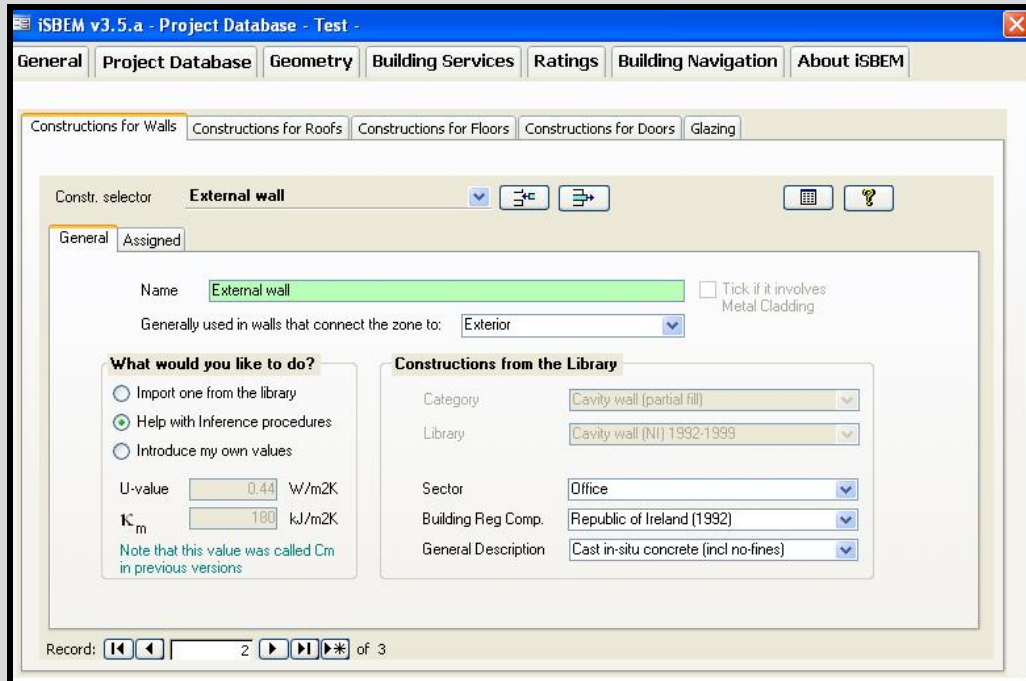

When this was converted into the current version of the software Version 3.5.b, the data is entered in "Introduce my own values" with the same U value and K_m value as the original software, as follows:

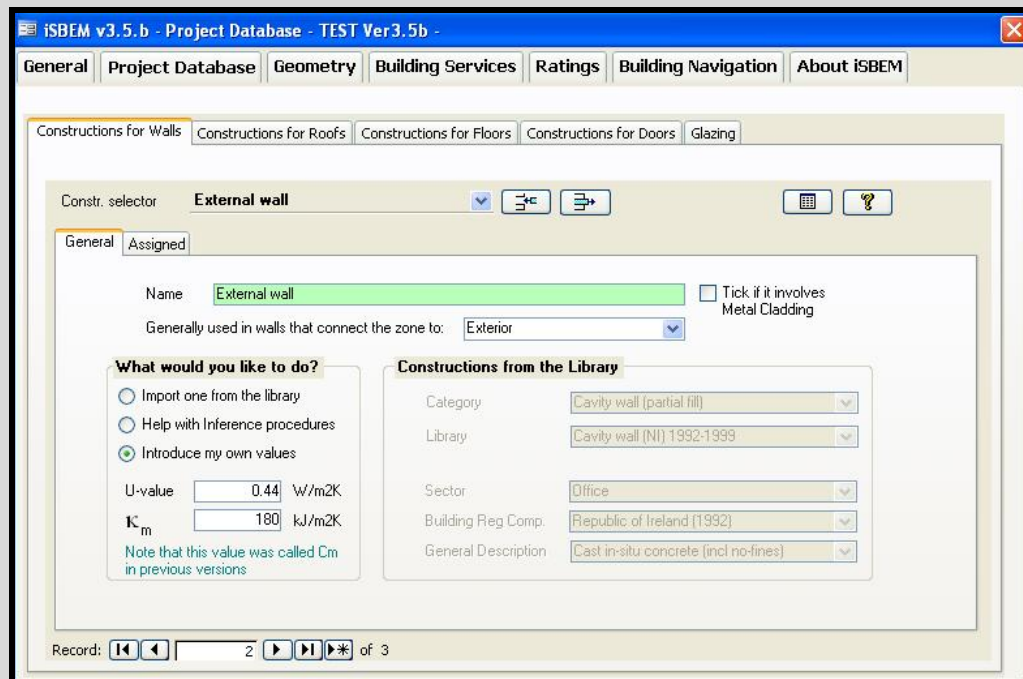

The U value and Km figures are copied to match Version 3.5.a, however when the default is selected

for this version of the software the U value changes to 0.45:

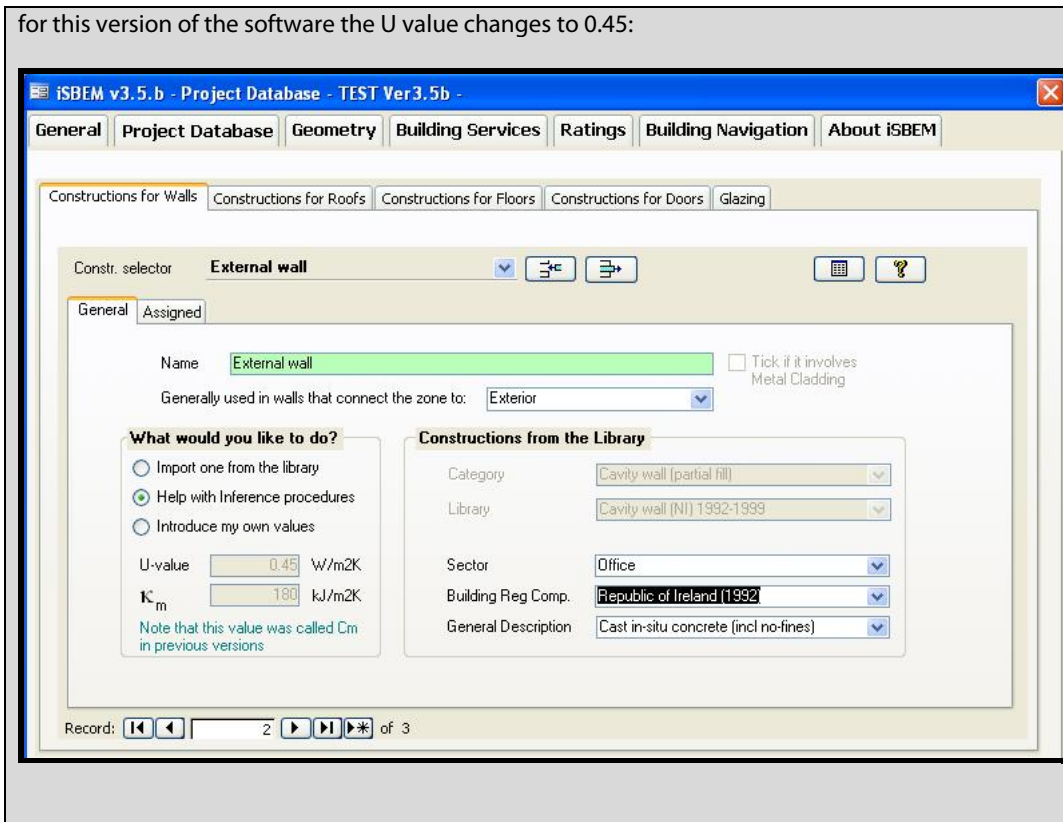

9 Quality Assurance – Quality of Photographic Evidence

BER Auditors have encountered photographic documentary evidence that has been submitted as part of a Quality Assurance check that is unacceptable.

As described in the [NEAP Survey Guide](#), “BER Assessors should endeavour to gather as much data, photographs and supporting evidence as possible to increase the likelihood of an accurate survey and assessment which will stand up to auditing by SEAI.”.

Issues have arisen during BER Audits regarding the quality of photographs taken by Assessors. Recurring problems include:

- blurred photographs – due to camera movement;
- underexposed photographs – particularly photos in poorly lit area’s such as boiler room when the flash has either not been used or used incorrectly;
- poorly focused photographs – caused by not giving the camera time to focus, not having sufficient distance between camera and object, or, misuse of the camera’s macro function.

This applies particularly to pictures of nameplates on boilers, heating systems, etc.

If an Auditor cannot make a clear appraisal of a photograph for reasons such as the issues mentioned above, or for any other reason, then the Assessor may be liable to disciplinary sanction under the BER QA scheme.

In order to minimise the likelihood of any problems occurring the Assessor is encouraged to read the camera’s manual to gain a full understanding of how the camera works, paying particular attention to the use of flash, macro and focus.

The following simple tips should also be adhered to:

- hold the camera steady;
- give the camera time to focus;
- for close-up shots, the camera’s macro function may take several seconds to gain correct focus;

- use the flash in poorly lit spaces (the camera’s auto-flash setting will do this automatically, generally with good results);
- when using the flash on a object several metres away try to ensure there are no objects in the foreground as this can affect the focus and/or over-expose the photograph;
- check the photograph and if it is not of sufficient quality **re-take** the photograph.

In responding to audit requests, all photographs must be labelled and the audit request should reference the specific photo/photographs as part of the response. In some cases, BER Assessors may wish to compress photographs to a smaller file size as smaller documents are easier to transmit by email. This is acceptable provided the photograph remains clear.

The following example demonstrates an example of a typical audit request and the photographic evidence required to show compliance.

Audit Request	Assessors Response
<p><u>Lighting - Occupancy Control</u> Please provide copies of As Built lighting specification and drawings/ Technical Data Sheets/ Photos to show compliance with Section 7.6.8 of the iSBEM User Guide Please provide details of how the following data was determined: Type of Control (Auto On-Off etc) Parasitic Power for Occupancy controls Refer to iSBEM User Guide Section 3.2 and NEAP Survey Guide for guidance on the documentary evidence required.</p>	<p>Please refer to the following attached documentation;</p> <ul style="list-style-type: none"> - Room Survey Form - Room Layout Drawings - Photographs lmg005 lmg010 lmg120

Example

- (i) A BER assessor demonstrating the lighting type and presence of lighting control in a zone should provide a photograph that clearly shows them, as shown below:



- (ii) A BER assessor demonstrating the heating generator type should ensure that any text is visible in the photo:





Non Domestic BER Assessors – Technical Bulletin

Issue No. 2/12

April 2012

Contents:

1	General - Year of Construction.....	2
2	Building Services - Building with Inadequate HVAC System	2
3	Building Services - Indirectly Conditioned Spaces	6
4	Envelope - Treatment of Adjoining Buildings.....	7
5	Envelope – Elements adjoining unheated spaces	11
6	Project Database – Windows and Rooflights	12
7	Building Services – Use of Data from ECA list	13
8	Building Services – HVAC System part of the Process Load	15

The Non-domestic BER Technical Bulletins are archived [here](#).

This technical bulletin addresses a number of queries recently encountered by the BER audit team and Helpdesk, including:

- Year of Construction
- Buildings with inadequate HVAC systems;
- Indirectly conditioned zones;
- Treatment of adjoining buildings;
- Treatment of elements adjoining unheated spaces
- Glazing performance.
- Use of data from the ECA list.
- Dealing with HVAC systems that form part of the process load

1 General - Year of Construction

The BER audit team have seen a number of assessments with an incorrect “Year of Construction”. The “Year of Construction” should be that of the original year of construction. Further information on the date of renovations and extensions can be provided in the “Location Description”.

Example

An office building was originally constructed in 1930, with a complete renovation of the building carried out in 2007 to meet the building regulations relevant in 2007.

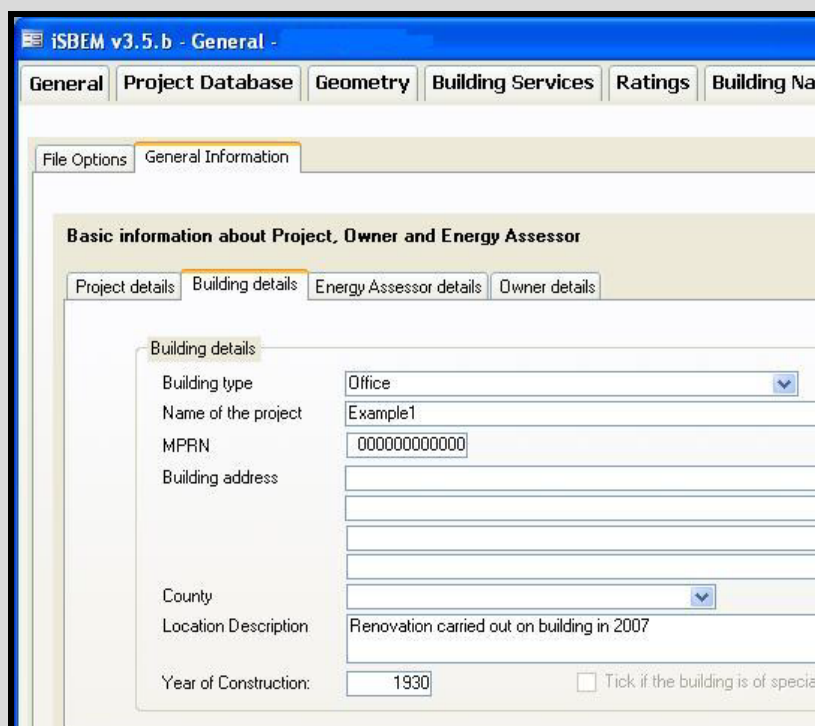

The screenshot shows the iSBEM v3.5.b software interface. The main window title is "iSBEM v3.5.b - General". The top menu bar includes "General", "Project Database", "Geometry", "Building Services", "Ratings", and "Building Nav". The "General Information" tab is selected, and the "Building details" sub-tab is active. The "Basic information about Project, Owner and Energy Assessor" section is visible, with the following fields:

Building type	Office
Name of the project	Example1
MPRN	000000000000
Building address	
County	
Location Description	Renovation carried out on building in 2007
Year of Construction:	1930

A checkbox labeled "Tick if the building is of special" is located at the bottom right of the form.

2 Building Services - Building with Inadequate HVAC System

Queries to the Helpdesk and results from audits have shown that clarity is required on treatment of zones with no HVAC system installed for various building types. This issue can have a significant impact on the BER result for the building.

Section 7.5.3 of the iSBEM user guide states “If a zone is defined as having no heating or cooling, i.e., assigned to ‘Zones without HVAC system’, but the activity type selected for the zone is one which typically requires conditioning (according to the Activity Database), a red exclamation mark “!” will appear next to this parameter as a warning to the user, in case this was done in error.”

The following gives guidance as to how the various building types should be treated:

1) Completed building with installed HVAC system

i.e. A building where construction has been completed and all HVAC systems have been installed.

For these building types a HVAC system is applied to every zone requiring conditioning based on the activity type assigned to it, as highlighted by the red exclamation mark “!”. If this type of zone has no installed HVAC system, the default HVAC system must be applied as detailed in section 7.5.3 of the iSBEM User Guide.

In general, the exception to this rule is a space with a transient/ passing occupancy such as internal toilets, changing facilities or tea making facilities which may not have heating or cooling installed. For these spaces “Zones without HVAC system” can be selected and it is acceptable for the red exclamation mark“!” to appear.

If an Assessor has an assessment where they believe that it is justified for ‘Zone without HVAC system’ to be applied to a zone which would typically require conditioning based on the activity applied to it, they should check with the BER Helpdesk prior to submitting the BER.

The following shows of how such a building is dealt with in SBEM:

Completed building with installed HVAC system

The building below is an existing office building with an installed HVAC system. The building is heated using a gas fired boiler serving a radiator system. The Assessor creates a HVAC system in SBEM called “Radiator System” to represent the installed HVAC system. Installed radiators are shown in green in the diagram.

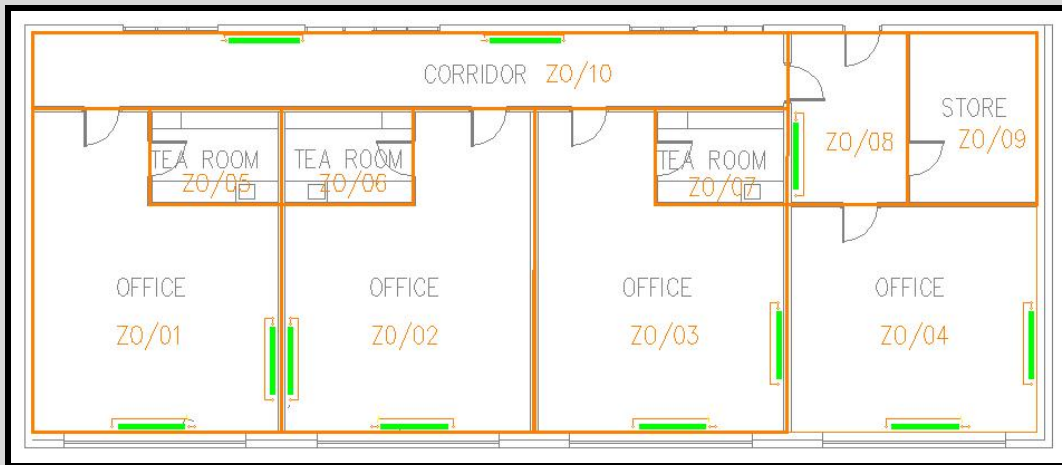

The following shows the HVAC system applied to each zone:

Zone	HVAC System applied	Reasoning
Z0/01 to Z0/04	Radiator System	Based on the installed system
Z0/05 to Z0/07	Zones without HVAC system	Although the activity applied to these zones “Tea Making Facility” would typically require conditioning, because they are internal transient spaces it is acceptable that no HVAC system is installed.
Z0/08 & Z0/10	Radiator System	Based on the installed system
Z0/09	Zones without HVAC system	Although the zone is adjacent to an external wall, the activity “Store” applied to it does not typically require conditioning:

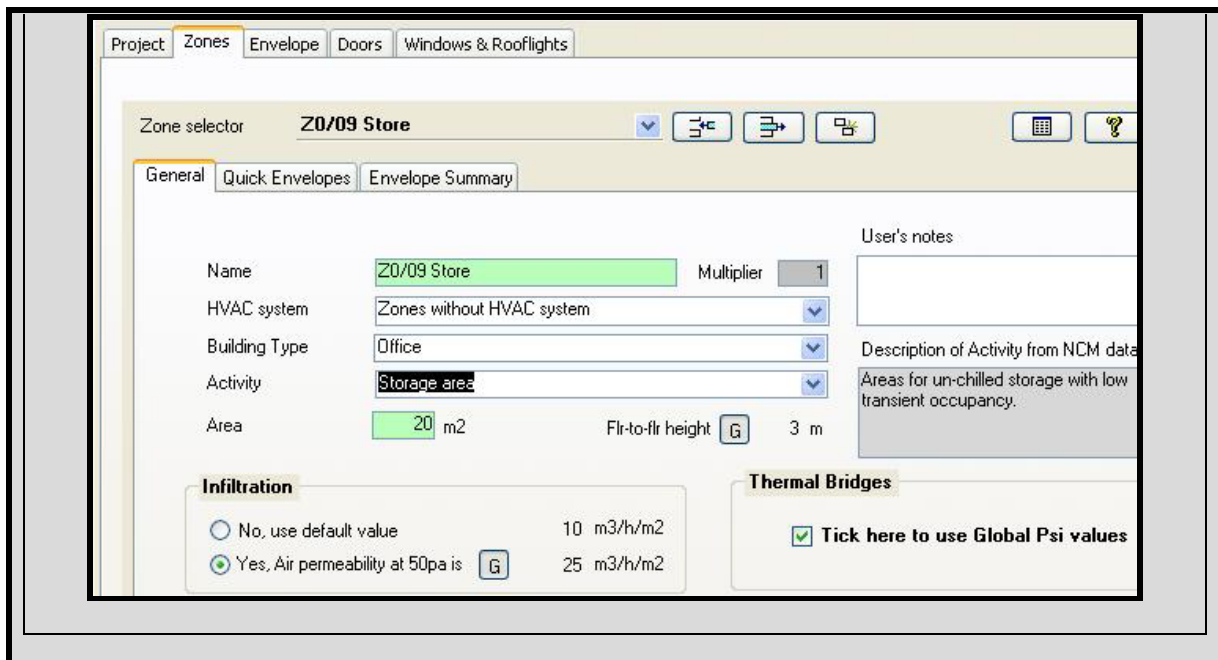

2) Completed building with partial/ no HVAC system

i.e. A building where construction has been completed, and where a HVAC system is expected but has not been completed or installed at the time of the BER assessment.

For these building types where no HVAC system has been installed or where a HVAC system has been partially installed, it is expected that a HVAC system be applied to every zone which requires conditioning based on the activity type assigned to it, as highlighted by the red exclamation mark "!".

For zones where a fixed HVAC system has been installed, select the HVAC system based on the installed system. For zones where no fixed HVAC system has been installed, the default HVAC system must be applied as detailed in section 7.5.3 of the iSBEM User Guide.

The following shows of how such a building is dealt with in SBEM.

Completed building with partial/ no HVAC system

The building below represents an existing office building where the HVAC system has been partially installed. The building is heated using a gas fired boiler which serves a radiator system. The Assessor creates a HVAC system within SBEM called "Radiator System" to represent the installed HVAC system. Installed radiators are shown in green in the diagram.

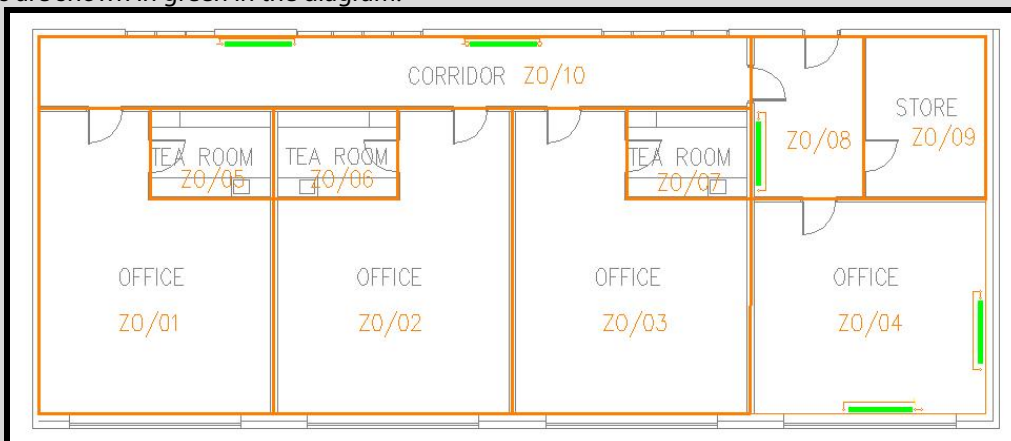

The following shows the HVAC system applied to each zone:

Zone	HVAC System applied	Reasoning
Z0/01 to Z0/03	Heating Only – Other Systems	<p>These spaces are adjacent to an external element and have the activity “Offices” applied to them. Offices would typically require conditioning and would be continually occupied; therefore a HVAC system must be applied.</p> <p>As no HVAC system has been installed, the Assessor must use a default system as per the NEAP Survey Guide A4.3. “Heating Only – Other Systems” is selected as there is a gas supply to the building and the spaces have the potential to be naturally ventilated. The following diagram shows that it is incorrect to select “Zones without HVAC system”.</p>

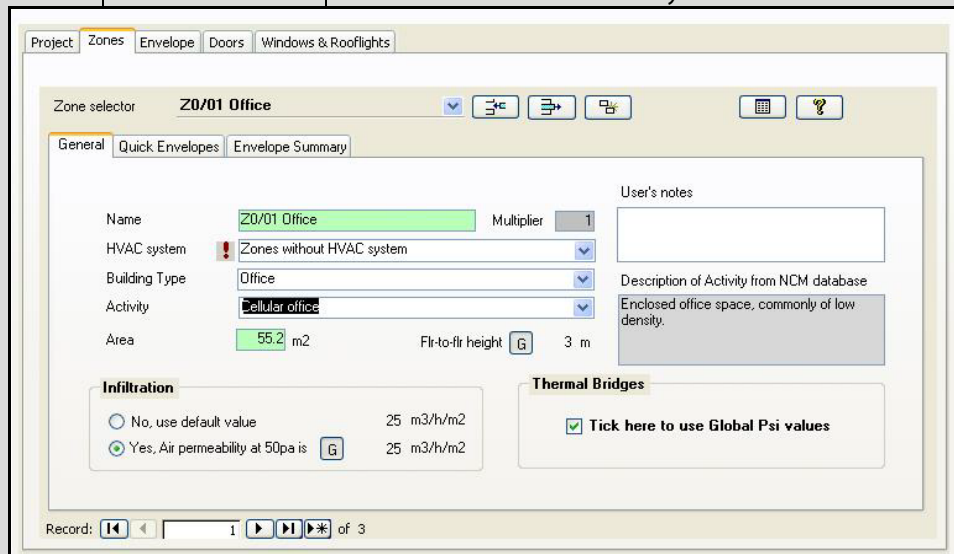

Z0/04, Z0/08 & Z0/10	Radiator System	Based on the installed system.
Z0/05 to Z0/07	Zones without HVAC system	Although the activity applied to these zones “Tea Making Facility” would typically require conditioning, because they are internal transient spaces it is acceptable that no HVAC system is installed.
Z0/09	Zones without HVAC system	Although an external zone, the activity “Store” applied to it does not typically require conditioning.

3) Completed building with no HVAC system due to high internal loads.

i.e. A building where construction has been completed, and where a HVAC system has not been installed due to the high internal loads.

For these building types, such as a Laundrette, where no heating or cooling has been installed because of the high internal load from a process within the building, Assessors must follow the guidance in the NEAP Survey Guide Section A4.9, applying the same heating system as that of the notional building. This means that the energy associated with the HVAC system does not impact on the rating as we are comparing like to like.

3 Building Services - Indirectly Conditioned Spaces

We have found in audits that Assessors are not correctly identifying indirectly conditioned spaces. Again, correct identification of a zone being conditioned, or not, can significantly impact the rating.

As outlined in section 7.6.8 of the iSBEM user guide, zones “which are not serviced by a HVAC system, i.e. have no direct supply of heating or cooling, but are likely to be indirectly conditioned by the surrounding areas due to the high level of interaction with those spaces (allowing the heated air to move freely from the directly conditioned spaces to the indirectly conditioned ones), they should be considered heated or conditioned (indirectly) by the same HVAC system that supplies the most important surrounding area”.

Note that an unconditioned enclosed zone should not be considered as “indirectly conditioned” as air cannot move freely from a directly conditioned zone to the unconditioned zone.

Take the following example:

Indirectly Conditioned Spaces

The building below represents an existing office building which is served by a radiator system. As can be seen zones Z0/01, Z0/02 and Z0/05 are directly heated by the radiator system. Zones Z0/03 and Z0/04 have no direct HVAC system. There is no partition between Z0/02 and Z0/03 so there will be movement of air from the heated offices into the corridor, therefore the corridor is indirectly heated. Zone Z0/04 is surrounded by partitions and totally enclosed. The heated air cannot move freely from the surrounding conditioned zones to Z0/04. Therefore the store is unconditioned.

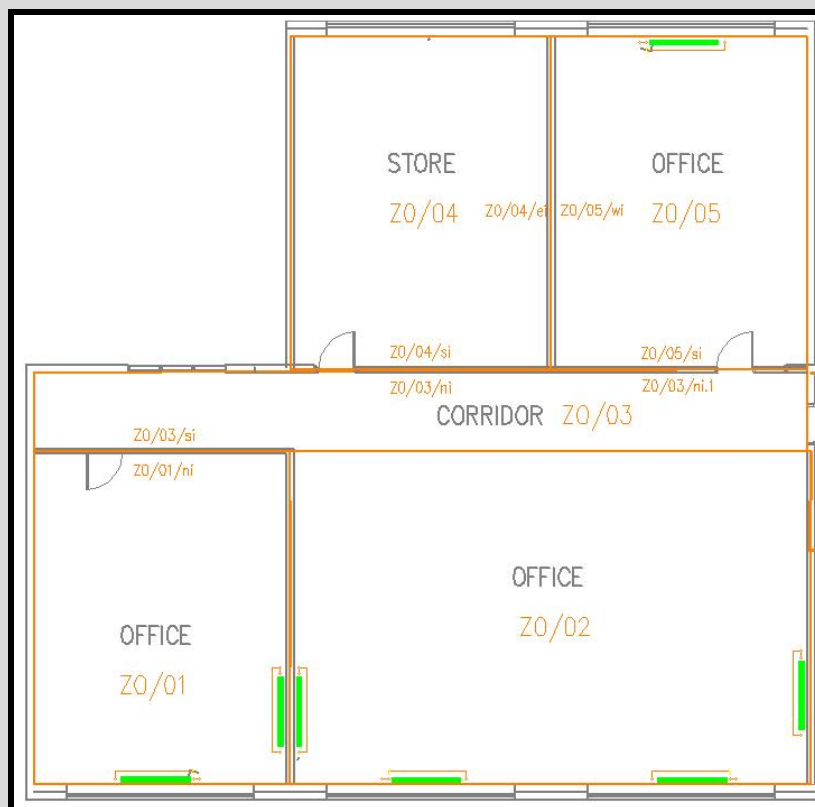

The following HVAC system should be applied to each zone:

Zone	HVAC System applied	Reasoning
Z0/01, Z0/02 & Z0/05	Radiator System	Directly heated
Z0/03	Radiator System	Indirectly heated by same system supplying surrounding zone.
Z0/04	Zones without HVAC system	Unconditioned & enclosed.

Some of the internal surface envelope conditions are as follows:

Element	Adjoining Condition	Reasoning
Z0/01/ni, Z0/04/si & Z0/05/si	Conditioned Adjoining Space	The elements are adjacent to Z0/03 which is indirectly heated.
Z0/03/si & Z0/03/ni.1	Conditioned Adjoining Space	The elements are adjacent to Z0/01 and Z0/05 respectively which are directly heated.
Z0/03/ni & Z0/05/wi	Unheated Adjoining Space	The elements are adjacent to Z0/04 which is unconditioned.

4 Envelope - Treatment of Adjoining Buildings

The Helpdesk have received a number of queries regarding treatment of elements adjoining other buildings or zones which do not form part of the BER such as neighbouring premises. If there is a heat loss through a building element, it must be correctly accounted for in the BER assessment.



Adjoining Spaces ~~which do not form part of the BER should be~~ are treated as follows in iSBEM. Further guidance is provided in the NEAP Survey Guide Appendices (Updated October 2013):

a) "Conditioned Adjoining Space" if the space adjoining the element (zx/xx/xi) has the same activity as the zone (zx/xx) or is normally heated to similar levels as the zone (i.e. heated to **at least the same a similar temperature (+/-5°C)**¹ for 90% or more of the duration of the zone being specified.)

b) "Unheated Adjoining Space" if the above condition is not met.

The heating regime should be determined as follows:

- 1) If there is access to details of the zones within the adjoining building, base the parameters for the element on the activity and installed HVAC system within that zone.
- 2) If there is no access to the zones in the adjoining building, base the parameter for the element on the building type using the following table of temperature profiles for common building types. These building types have been selected from the Activity Database for common building types which would be typically adjoining a non domestic building. The table is based on the activity database for the main activities within each of the building types.

Building Type	Weekly Temperature Profile	Annual Temperature Profile
Airport Terminal	Mon to Sun: 12°C - 0 to 24	All Year
Transport Terminal	Mon to Sun: 12°C - 0 to 24	All Year
Community/Daycare Centre	Mon to Fri: 12°C - 0 to 7	All Year

¹ Updated during NEAP Survey Guide Review October 2013.

	22°C - 7 to 18 12°C - 18 to 24 Sat to Sun: 12°C - 0 to 24	
Primary Health Care	Mon to Fri: 12°C - 0 to 6 22°C - 6 to 18 12°C - 18 to 24 Sat to Sun: 12°C - 0 to 24	All Year
Further Education University	Mon to Fri: 12°C - 0 to 7 20°C - 7 to 20 12°C - 20 to 24 Sat to Sun: 12°C - 0 to 24	Jan 1 to Jan 12: 12°C Jan 13 to Mar 20: Weekly Profile Mar 21 to Apr 3: 12°C Apr 4 to June 12: Weekly Profile June 13 to Sept 25: 12°C Sept 26 to Dec 11: Weekly Profile Dec 11 to Dec 31: 12°C
Restaurant/public house	Mon to Sun: 12°C - 0 to 6 23°C - 6 to 23 12°C - 23 to 24	All Year
Theatres/cinemas/music halls and auditoria	Mon to Sun: 12°C - 0 to 8 22°C - 8 to 22 12°C - 22 to 24	All Year
Office	Mon to Fri: 12°C - 0 to 6 22°C - 6 to 19 12°C - 19 to 24 Sat to Sun: 12°C - 0 to 24	All Year
Retail	Mon to Sat: 12°C - 0 to 7 20°C - 7 to 19 12°C - 19 to 24 Sun: 12°C - 0 to 8 20°C - 8 to 17 12°C - 17 to 24	All Year
Warehouse	Mon to Sun: 12°C - 0 to 24	All Year
Workshop/ Maintenance Depot	Mon to Sun: 12°C - 0 to 24	All Year

- 3) The Assessor can also base the heating regime in specific building types or zones by referring to the [iSBEM activity database](#) (see “NCM Databases”).

The following shows an example of how the activity database may be used.

Determine in iSBEM whether it is expected that the activity in the adjoining building requires heating. Then select “Zones without HVAC system” and the activity of the adjoining building. If the red exclamation mark appears “!”, proceed to the activity database as the space is expected to be heated. If the red exclamation mark does not appear it is assumed that the space is unheated.

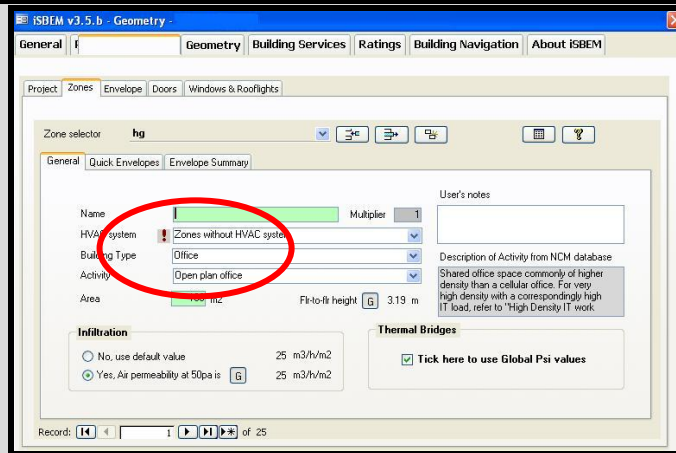

On proceeding to the activity database, determine the heating profile of the adjoining building. Then select the activity under “Object Selector” in the “Activity” tab of the database. In the same tab, identify the heating profile under “Heat”.

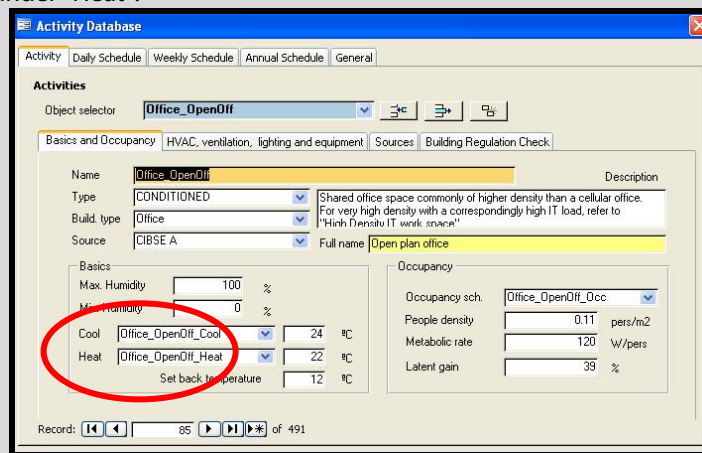

Then proceed to the “Annual Schedule” tab to determine the annual profile.

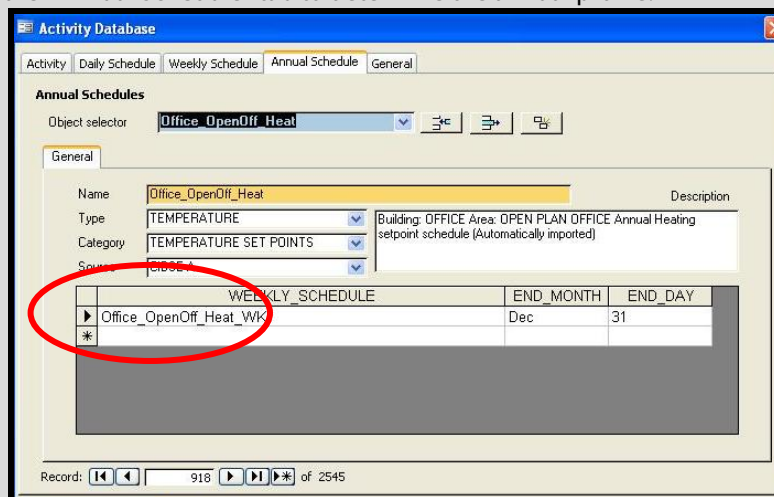

Proceed to the “Weekly Schedule” tab to determine the weekly profile.

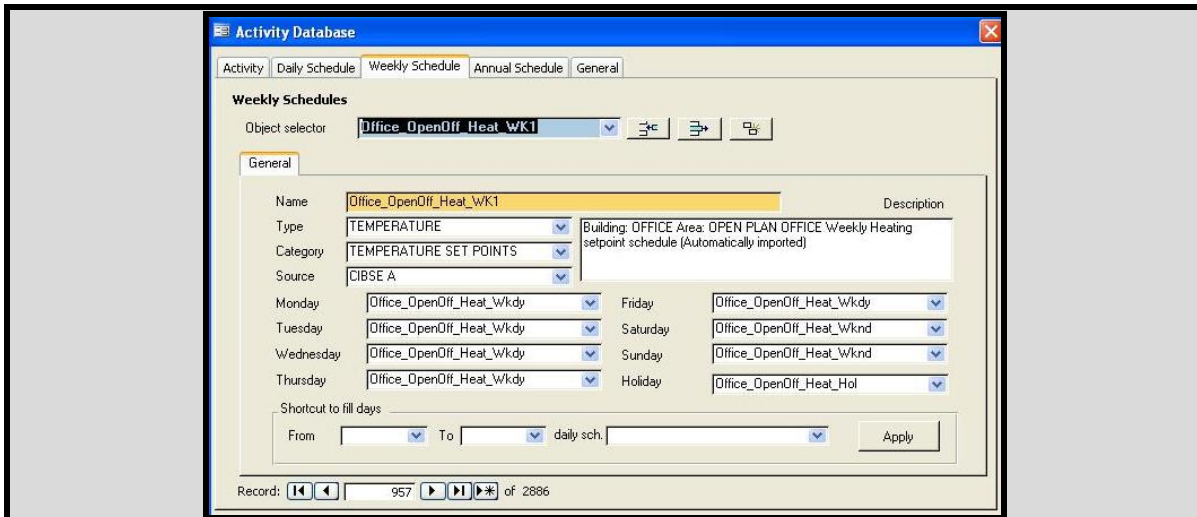

Proceed to the "Daily Schedule" tab to determine the daily profile.

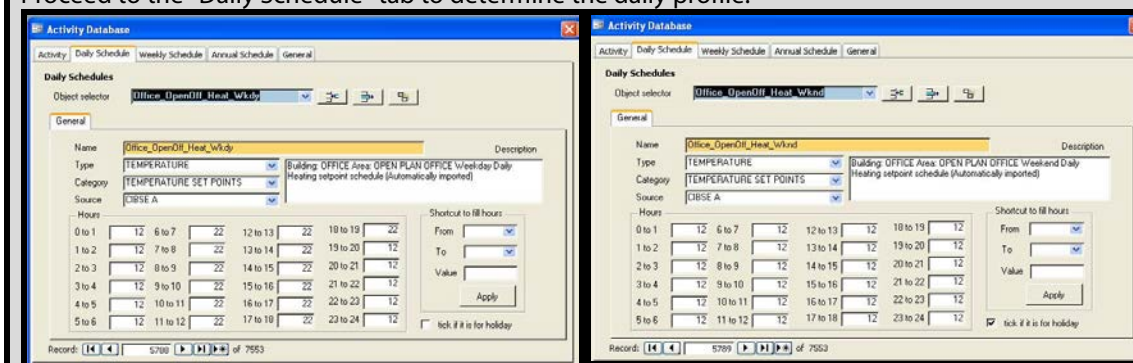

In this case the office is heated from 6am to 7pm to 22°C Monday to Friday for 52 weeks of the year with a background temperature of 12°C maintained at other times.

If unable to determine the nature of the neighbouring premises, then conservative assumptions should be made, therefore assuming that the adjoining space is unconditioned.

5 Envelope – Elements adjoining unheated spaces

The U-value of elements connecting to an “Unheated Adjoining Space” must account for the effect of the unheated space. The procedure for calculating the U value is described in the Non Domestic Building Regulations Part L Technical Guidance Document and in Appendix A of [BR 443:2006](#).

$$U = 1 / ((1/U_o) + R_u)$$

where:

- U is the resultant U-value of the element adjacent to unheated space, W/m²K;
- U_o is the U-value of the element between heated and unheated spaces calculated as if there were no unheated space adjacent to the element, W/m²K;
- R_u = effective thermal resistance of unheated space.

R_u values for typical unheated structures (garages, corridors, stairwells) are given in Building Regulations TGD L Appendix A or alternatively for other cases the R_u value can be calculated in compliance with Appendix A of BR443:2006.

$$R_u = A_i / (\sum (A_e \times U_e) + 0.33nV)$$

where:

- A_i the area of the internal element being calculated, m²;
- A_e is the area of the external elements, excluding ground floor m²;
- U_e is the U-value of the external elements
- n is the air change rate (ach) of the unheated space
- V is the volume of the unheated space m³.

SEAI have published a Frequently Asked Question and tool (October 2013) to address “Elements adjoining unheated spaces” simplifying the calculation and has introduced a tolerance where U-value adjustment in SBEM is not required if the impact of the adjustment is expected to be negligible. Please refer to www.seai.ie/berfaq and the NEAP Survey Guide Appendices for more detail.

The following example identifies and applies an R_u value:

The diagram below shows a conditioned zone Z0/01 with an adjoining unheated zone Z0/05. The element between the two zones is a 225mm solid brick wall without insulation. The unheated tearoom has no external elements and an unknown air change rate, therefore a default of n=3 is used (see Table A5, BR 443). The zones are 3m high.

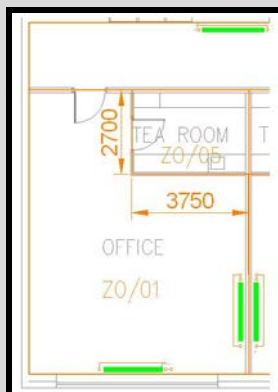

The U-value of the element between the two zones, without allowing for the fact that it is adjoining an unheated space is 2.1 W/m²K, as taken directly from the iSBEM library.

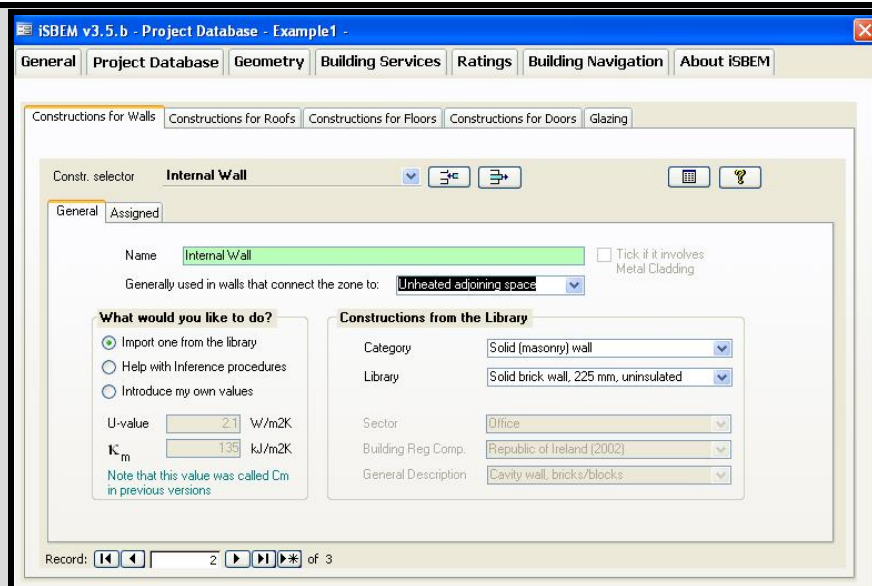

Following BR443:2006, the Ru value is calculated as follows:

$$Ru = Ai / (\Sigma (Ae \times Ue) + 0.33nV)$$

$$Ai = (2.7 + 3.75) \times 3 = 19.35m^2$$

$$\Sigma (Ae \times Ue) = 0$$

$$V = (3.75 \times 2.7 \times 3) = 30.375m^3$$

$$Ru = 19.35 / (0.33 \times 3 \times 30.375) = 0.643$$

Following BR443:2006 and TGD Part L, the U value is calculated as follows:

$$U = 1 / [(1/U_o) + R_u]$$

$$U = 1 / [(1/2.1) + 0.643]$$

$$U = 0.9$$

The user then updates the U-value in iSBEM to allow for the unheated space. The Km value is unaltered.

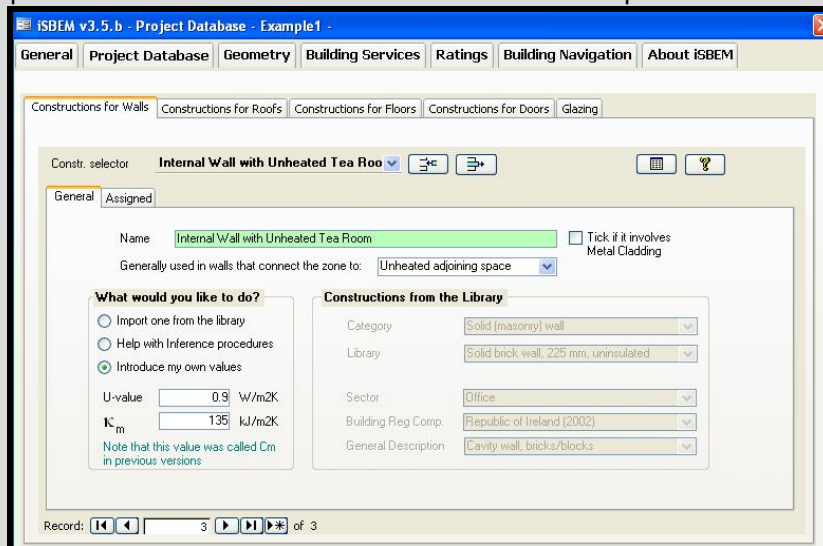

6 Project Database – Windows and Rooflights

BER Assessors regularly encounter glazing systems with a film or signage applied to the glass to advertise/ promote services or products.

BER ratings are based on an asset rating and not on operational parameters which are influenced by occupier behaviour. Therefore in the case above the promotional film that has been added is regarded as occupier behaviour and should be ignored for the purposes of the BER assessment.

7 Building Services – Use of Data from ECA list

A number of BER Assessors have asked the BER Helpdesk about using the [ECA/ ETL list](#) (Enhanced Capital Allowance Scheme/ Energy Technology List) in the UK as a source of efficiency data for Building Services products for use in non-domestic BERs.

If using data from the website, ensure that the data complies with the relevant standards in the [Non Domestic Building Services Compliance Guide](#) and ensure that the relevant methodology from the compliance guide is used to determine the seasonal efficiency.

Assessors can review compliance with the relevant standards under criteria for each product.

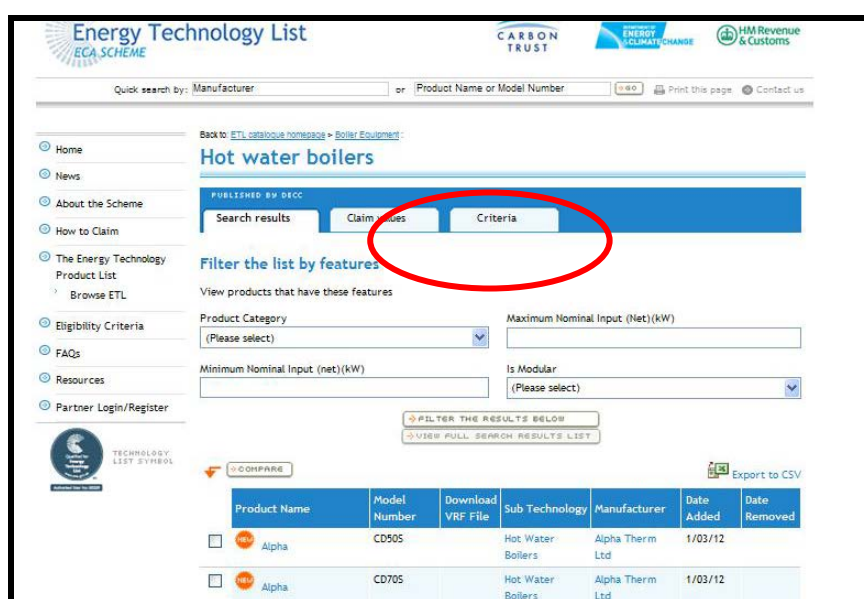

The data from the website may need to be altered to comply with the Non Domestic Building Services Compliance Guide as shown in the following example:

The following shows an example of data supplied for a particular boiler:

Back to [ETL catalogue homepage](#) > [Boiler Equipment](#) > [Hot water boilers](#) :

Product details

PUBLISHED BY THE CARBON TRUST PUBLISHED BY DECC

Manufacturers Product details

Product name	Alpha
Model number	CD505
Date added	01 Mar 2012
Date removed	n/a
Product tested	No

Product features

Name	Value
Product Category	Condensing (all kW ratings)
Maximum Nominal Input (Net)(kW)	56.4
Minimum Nominal Input (net)(kW)	11.5
Is Modular	Yes
No (of) Modules	4
Fuel Type	Gas
Burner Type	Integrated
Burner - standard	Equivalent burner
Net efficiency at full load (100%)	98.5
Net efficiency at part load (30%)(%)	106.5
Turndown ratio (e.g. 2:1)	4:1

Assessors should note that the data is given for net efficiency and not gross efficiency.

Therefore the seasonal efficiency is calculated as follows:

1) Efficiency is converted to Gross Efficiency, based on SAP or Table E4 of the DEAP manual as shown below (this follows the guidance in the Non-domestic Compliance Guide Table 1:

$$\text{Gross Efficiency at 100\% load: } 98.5\% \times 0.901 = 88.7\%$$

$$\text{Gross Efficiency at 30\% load: } 106.5\% \times 0.901 = 96.0\%$$

Table E4: Efficiency conversion factors

Fuel	Net-to-gross conversion factor
Natural gas	0.901
LPG (propane or butane)	0.921
Oil (kerosene or gas oil or other biofuels)	0.937
Wood fuels	0.91
Solid multi-fuel	0.94

2) Seasonal Efficiency is calculated, based on Section 2.4 of the Non Domestic Building Services Compliance Guide:

$$\text{Seasonal Efficiency: } 0.81 \times 96.0\% + 0.19 \times 88.7 = 94.6\%$$

Note that it is acceptable to use calculation tools downloaded from the ECA/ETL site where the calculation methodology complies with the relevant standards from the Non Domestic Building Services Compliance Guide. Assessors are responsible for any changes they make to the spreadsheet and for the data that they input. As always, obtain the relevant documentary evidence to support calculations made and keep these documents on file.

An example of such a spreadsheet is as follows:

The following shows an example of a calculation spreadsheet for a split air conditioning system:

VRF ETL Compliance Check

To check the compliance of an Air Source VRF Heat Carry out the following:

- Select Outdoor Unit Model from Drop down menu:
- Select Indoor Unit Model from Drop down menus:
- Identify number of selected IDUs

If you type in an INVALID unit not in the picklist, OR leave values in when changing ODU, OR the ODU does not have a valid list identifier, then the cell will turn red - please select a valid one/blank or edit the ODU

Outdoor Unit Model	Nom Cooling Capacity (kW)	Nom Heating Capacity (kW)	Indoor units Min	Indoor units Max	Connected Capacity Min (kW)	Connected Capacity Max (kW)	Indoor Unit Model	No. of IDU's	Nom Cooling Capacity each	Total kW	EER	COP	Qualifies for ETPL 2
RXYSQ4PV	11.2	12.5	2	6	5.6	14.56	FXAQ32M	3	3.60	10.80			
<p>Current ETPL Values From August 2009</p> <p>EER > 3.30</p> <p>CoP > 3.70</p> <p>Qualifies for ETPL? YES</p> <p>Current Selection RXYSQ4PV</p> <p>Maximum Connected Capacity - 14.56 kW</p> <p>Minimum Connected Capacity - 5.60 kW</p> <p>Actual Connected Capacity - 10.80 kW</p> <p>Connected (% of Manufacturer's capacity) - 96.0%</p> <p>Cooling Duty - 10.75 kW</p> <p>Cooling Power Input ODU + IDUs - 3.14 kW</p> <p>EER - 3.42</p> <p>Heating Duty - 12.00 kW</p> <p>Heating Power Input ODU + IDUs - 3.19 kW</p> <p>CoP - 3.76</p>													
Valid Combination					Connected (% of Capacity)		96.0%	3	Connected Total	10.80 kW	3.42	3.76	YES

When you select an Outdoor Unit Model in the green cell above, the pick list in the Indoor Unit Model column (Column J) will change to match the selection. REMEMBER to delete all existing entries out of columns I and J before changing the Outdoor Unit Model. The cell will turn red if either you type in an invalid ODU model into the cell OR you have entered more than one row in the ODU sheet for that model name OR there are data errors with that ODU - please check

The Assessor has details of the outdoor and indoor units within a building, in this case the details are as follows:

Outdoor Unit : Daikin RXYSQ4PV
Indoor Unit : Daikin 3no FXAQ32M

The tool calculates the Cooling EER as 3.42 and the Heating COP as 3.76.

8 Building Services – HVAC System part of the Process Load

A recent question to the Helpdesk asked how a HVAC system should be entered for cold rooms or chilled rooms in iSBEM. Where space conditioning is provided for goods and not the occupants, the system should be considered a part of the process load. In this case the HVAC system assigned to the zone in iSBEM should be "Zones without HVAC system".

The issue in this particular case arose where an Assessor had a cold room (i.e. temperature was below 0°C) and a chilled room (i.e. temperature was greater than 0°C). Based on the current version of the software the following activities should be applied:

- Cold Room: Storage area - cold room (<0degC)
- Chilled Room: Warehouse storage – chilled

The description given in the iSBEM software on how to deal with the HVAC system is quite clear for the cold room activity "A storage area kept at below 0degC. Cooling load is assumed to be a process load and therefore not included in the calculation."

SEAI have obtained clarification from BRE on the chilled room activity description in iSBEM: "Large (warehouse sized) storage area containing items which need to be chilled. The area itself can be conditioned." BRE have stated that, where the cooling load is part of the process load, BER Assessors should not include this in the calculation i.e. "Zones without HVAC system" is applied to the zone.



Non Domestic BER Assessors – Technical Bulletin

Issue No. 3/12

October 2012

Contents:

1	Building Services - Building with Inadequate HVAC System	2
1.1	Heating provided by process load	4
1.2	Zones that are a “Shell”	5
1.3	Unheated Zones that are not a “Shell”	6
2	Envelope – Elements adjoining unheated spaces	7
3	Building Services – Shell and Core Buildings	12
4	General – Supporting Evidence for BERs	13
4.1	Building Owners Knowledge – Building Age	13
4.2	Electricity Power Factor in New Buildings	13
4.3	“Issued for Construction” drawings	13
5	Quality Assurance System and Disciplinary Procedure (QADP)	14
6	Audit Request Compliance	14

The Non-domestic BER Technical Bulletins are archived [here](#).

1 Building Services - Building with Inadequate HVAC System

The BER Helpdesk have received a number of queries following on from April’s Technical Bulletin in relation to “Buildings with Inadequate HVAC System”. The following is a flow chart summarising how to proceed based on the conditions within the building:

Building Heating System Flow Chart

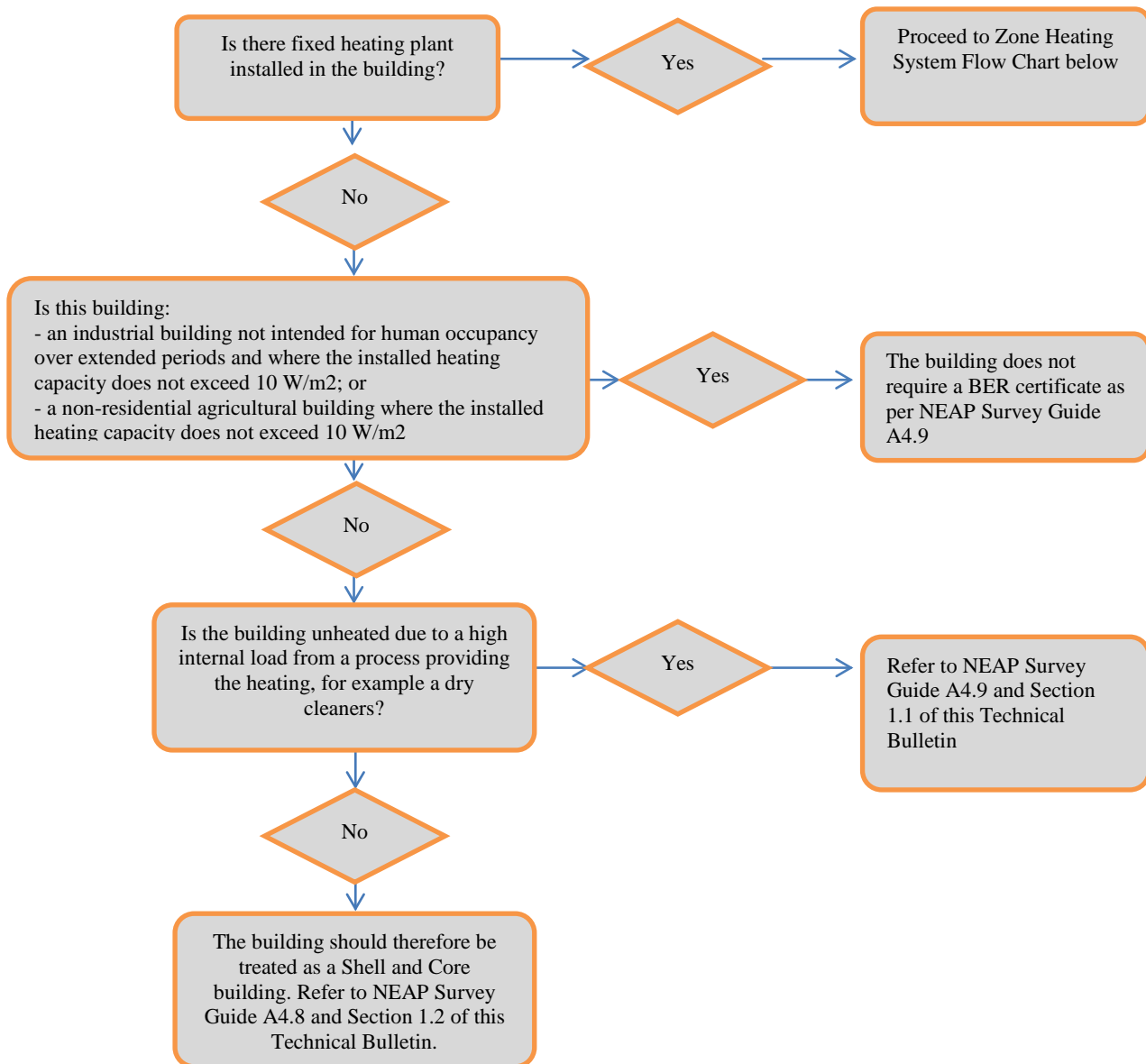

Zone Heating System Flow Chart

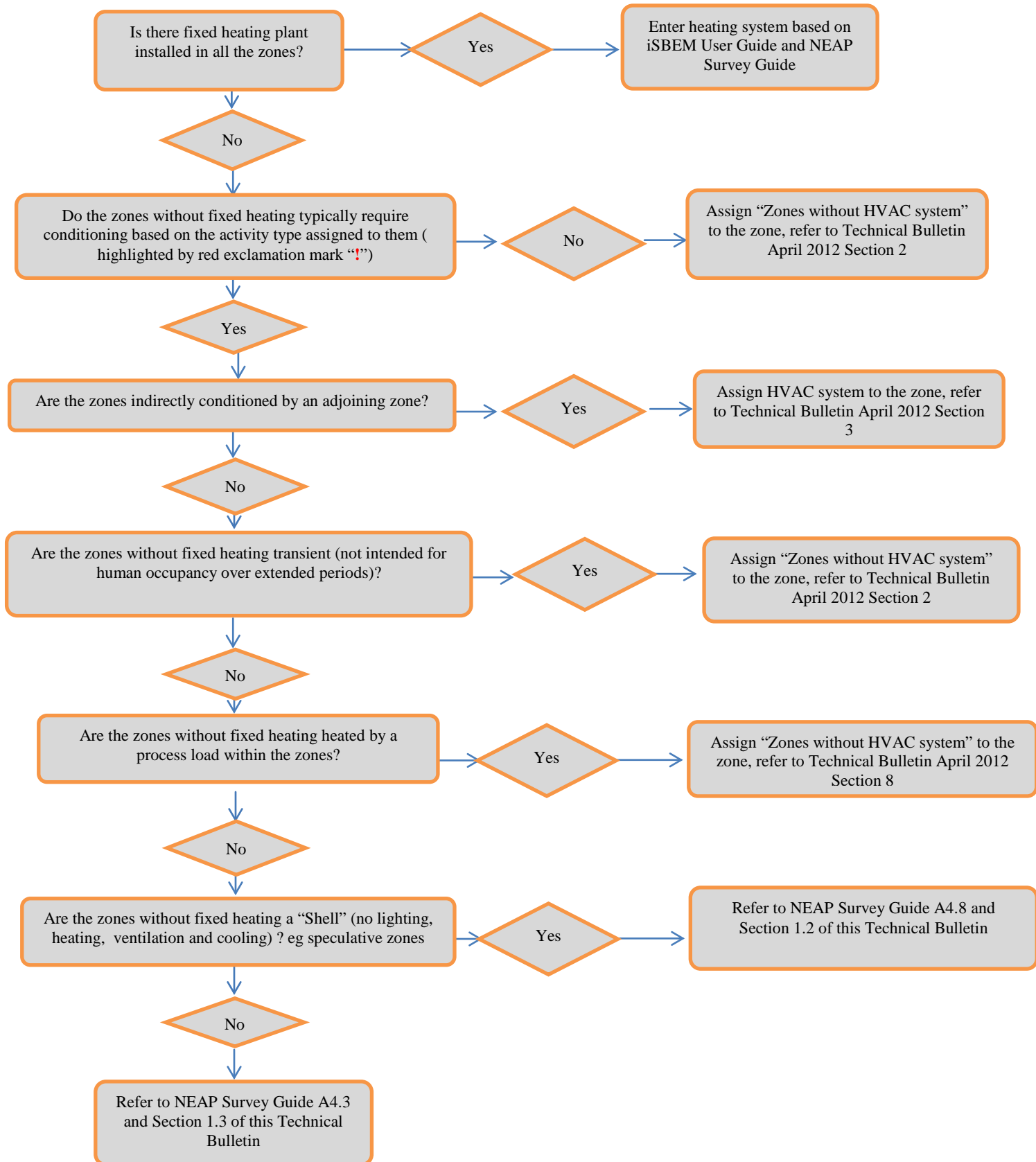

1.1 Heating provided by process load

Where a **building** is unheated due to a process or high internal load being present, follow the guidance set out in the NEAP Survey Guide A4.9. Base the heating system on the notional building's heating system and apply it to all zones.

This approach is required as SBEM will only run where a HVAC system is assigned to at least one of the zones in the building. Entering the notional building's heating system means that the BER is not benefitting or being penalised for having no heating system. If a **zone** is unheated due to a process load being present, refer to the guidance in Technical Bulletin April 2012 Section 8.

As outlined in the iSBEM User Guide Section 2.3, the notional building heating system is based on the following parameters:

- The efficiency in the notional building is identical to the reference building used for building regulation compliance.
- The space heating is always met by a gas fired system.

The following example shows a heating system with the same heating system efficiency as the notional building:

Notional building system efficiency example:

Create a Notional Heating System with the following type "Central heating using water: radiators". Assign Natural Gas to the fuel type and allow for the HVAC system to use Variable Speed pumps. Set the effective heat generating seasonal efficiency to 0.78:

Record selector: **Notional Heating System**

General Heating Cooling System Adjustment Metering Provision System Controls Zone Summary

Heating system

Heat source: LTHW boiler

Fuel type: Natural Gas

Tick if this HVAC system uses variable speed pumps

Does it qualify for UK ECAs?
ECA list (after 2001)

Was it installed in or after 1998?
 No Yes

Tick if this system also uses CHP

Do you know the effective heat generating seasonal efficiency?
 No, use default value 0.89
 Yes, seasonal efficiency is 0.78

Do you know the generator radiant efficiency?
 No, use default value 0.4
 Yes, radiant efficiency is 0.4

Allow for the HVAC system to be separately submetered with M&T alarms:

Record selector **Notional Heating System**

General Heating Cooling System Adjustment **Metering Provision** System Controls Zone Summary

Metering provision

Is this HVAC system separately sub-metered?

No or don't know
 Yes, it is

M&T with alarm for "out of range" values?

No or don't know
 Yes, it does

The HWS system assigned to the building will be based on the actual building and should not be linked to the heating system.

Check that the efficiency of the heating system matches the reference building and hence the notional building in the BRIRL - Output Document described under section 8.2.2 of the iSBEM User Guide. Refer to the HVAC system performance section of that iSBEM output:

HVAC Systems Performance									
System Type	Heat dem MJ/m2	Cool dem MJ/m2	Heat con kWh/m2	Cool con kWh/m2	Aux con kWh/m2	Heat SSEEF	Cool SSEER	Heat gen SEFF	Cool gen SEER
[ST] Central heating using water: radiators, [HS] L [HW boiler, [HFT] Natural Gas, [CF] Grid Supplied Electricity									
Actual				0	2	0.73	0	0.78	0
Reference				0	2	0.73		---	---

Note: The actual **Heat SSEEF** entry (the heating system seasonal efficiency) should equal the reference **Heat SSEEF**. If ventilation or exhaust has been added to a zone the auxiliary energy may differ. To ensure that the heating system is set up correctly, turn off all ventilation and exhausts in the iSBEM zones. Then check that the "Aux con" (auxiliary energy) for the actual building matches the "Aux con" for the reference building. Once this is confirmed turn on the ventilation and exhaust in the zones as appropriate and run the final BER.

1.2 Zones that are a "Shell"

A "Shell" would typically be a zone where only the bare structure is in place, internal fittings such as flooring and ceiling finishes, lighting, heating, cooling or ventilation have yet to be installed. For example a retail unit to be fitted out at a later date by a tenant.

In relation to the servicing of the shell, follow guidelines set out in Appendix A4.8 of the NEAP Survey Guide as follows:

Data Entry Item	Default Value ¹
Proposed Design Available	Where a proposed mechanical and electrical design is available, the HVAC and lighting system are based on the mechanical and electrical specifications, schedules and drawings for the shell and core unit.

¹ Updates as per red font to align to revised NEAP Survey Guide (October 2013). See Appendix 4 of the NEAP Survey Guide.

<p>No Design Available – Electrical Supply Only to Unit</p>	<p>HVAC System: Select default system “Heating and Mechanical Cooling” which is based on Terminal reheat (constant volume) and air cooled chiller. Where no alternate fuel is present in the building, “Natural Gas” is selected as the heating fuel. Currently electricity is not available as a heating fuel for the default system, “Natural Gas” is selected as it is the heating fuel used in the notional building.</p> <p>A HVAC system is assigned to every zone where the activity type selected for the zone is one which typically requires conditioning (according to the Activity Database), and a red exclamation mark “!” appears.</p> <p>HWS System: “Instantaneous Hot Water only” is selected with a fuel type of “Grid Supplied Electricity”.</p> <p>HWS System Storage/ Secondary Circulation Losses: Not present.</p> <p>Lighting: Lighting Parameters Not Available; Lamp Type: Don’t Know.</p> <p>Lighting Controls: Local Manual Switching.</p>
<p>No Design Available – Electrical and Alternate Fuel (oil/gas etc) Supplied to Unit</p>	<p>HVAC System: Select default system “Heating and Mechanical Cooling” which is based on “Terminal reheat (constant volume)” with fuel type as available on site for heating. Air cooled chiller used for cooling.</p> <p>A HVAC system is assigned to every zone where the activity type selected for the zone is one which typically requires conditioning (according to the Activity Database), and a red exclamation mark “!” appears.</p> <p>HWS System: “Dedicated Hot Water Boiler” is selected with a fuel type based on fuel supplied to unit</p> <p>HWS System Storage/ Secondary Circulation Losses: Not present</p> <p>Lighting: Lighting Parameters Not Available; Lamp Type: Don’t Know</p> <p>Lighting Controls: Local Manual Switching</p>

Assessors and clients should note that once the zone has been fitted out the BER certificate may no longer be valid if there is a material change in the building affecting the energy performance.

1.3 Unheated Zones that are not a “Shell”

These are zones meeting the following criteria:

- There is no fixed heating installed;
- There are floor and ceiling finishes, lighting, and ventilation as appropriate;
- The Activity Type requires conditioning;
- There is no proposal to fit out the zone with services in the future;
- Not considered transient or indirectly heated spaces.

We have had a number of examples of such zones including:

- a. Plug In Heaters (such as portable heaters) installed in a zone
- b. Heating has been removed from the zone.

In this case, a HVAC system must be assumed to be present. Follow guidelines set out in Appendix A4.3 of the NEAP Survey Guide.

iSBEM Software Tab: "HVAC"	
Data Entry Item	Default Value
No evidence of a HVAC present	<p>The default HVAC systems for buildings are as follows:</p> <ul style="list-style-type: none"> 'Heating only - Electric resistance' - Assumed to be electric central heating system with warm air distribution. If you do not know the heating method you should select electric resistance heating as your default. "Heating only - Other systems' - Assumed to be wet radiator system, heat generated by fuel combustion. 'Heating and mechanical cooling' - Assumed to be constant volume air system with terminal reheat and fixed fresh air. This is the assumed HVAC system in the absence of other information for conditioned spaces. If no HVAC system serves a zone (ie an unconditioned zone) select "Zone without HVAC system" <p>For details Refer to 7.5.3 of the iSBEM User Guide.</p>

Note: Appendix A4.3 of the NEAP Survey Guide gives Assessors the option of selecting "Zone without HVAC system". However this is only in the case where it has been justified, as per the Zone Heating System Flow Chart above, that a HVAC system is not required in the zone.

2 Envelope – Elements adjoining unheated spaces

Following the April 2012 Technical Bulletin, we have had a number of additional queries regarding how to calculate the R_u value for elements adjacent to unheated spaces. The following are examples of standard arrangements. SEAI have published a Frequently Asked Question and tool (October 2013) to address "Elements adjoining unheated spaces" simplifying the calculation and has introduced a tolerance where U-value adjustment in SBEM is not required if the impact of the adjustment is expected to be negligible. Please refer to www.seai.ie/berfaq and the NEAP Survey Guide Appendices for more detail.

Example 1: Element Adjacent to Large Unheated Volume

The following example adjusts the U-value of an office wall adjacent to an unheated warehouse.

The diagram below shows a conditioned zone Z0/02 with an adjoining unheated zone Z0/01. The element between the two zones has an unadjusted U-value of 1.7 W/m²K. As part of the BER assessment the Assessor has found the required documentary evidence to support the U-values of the building elements. The unheated warehouse has a number of large permanent ventilation openings.

Following BR443:2006 Appendix A, the R_u value is calculated as follows:

$R_u = A_i / (\sum (A_e \times U_e) + 0.33nV)$

$\sum (A_e \times U_e)$ refers to external surfaces of the unheated space and is as follows:

Element	Area (m ²)	U Value (W/m ² K)	A _e x U _e
Walls	(61.6 x 6) – (7x2.5x2) = 334.6	0.6	200.76
Doors	7x2.5x2 = 35	3	105
Roof	26 x 9.6 = 249.6	0.25	62.4
$\sum (A_e \times U_e)$			368.16

Note: As per Appendix A of BR 443: 2006 ground floor of the warehouse is omitted.

$A_i = 9.6 \times 3 = 28.8\text{m}^2$
 $\sum (A_e \times U_e) = 368.16$
 $V = (26 \times 9.6 \times 6) = 1497.6\text{m}^3$
 $n = 10$, from Table A5 of BR443:2006
 $R_u = 0.0054 \text{ m}^2\text{K/W}$

Following BR443:2006 and TGD Part L, the U value is calculated as follows:
 $U = 1 / ((1/U_o) + R_u)$

$U = 1 / ((1/1.7) + 0.0054)$
 $U = 1.68 \text{ W/m}^2\text{K}$

Example 2: Element Adjacent to Small Unheated Volume

The following example adjusts the U-value of a meeting room wall adjacent to an unheated staircore:

The diagram below shows a conditioned zone Z1/01 Meeting Room with an adjoining unheated zone Z1/02 Stairs.

The building was built in 2008 and there is insufficient evidence available to substantiate non-default U-values. Therefore default U-values are used for the building based on the NEAP Survey Guide A4.2. The External and Internal Wall U values are obtained using the inference method in iSBEM. The Window U-Values are obtained using the library database.

- External Wall U-value: 0.27 W/m²K
- Window U-value: 2.8 W/m²K
- Internal Wall U-value: 2.1 W/m²K

The building is air tight with all joints well sealed. Small openings are provided for ventilation within the stairs.

Following BR443:2006 Appendix A, the Ru value is calculated as follows:

$$R_u = A_i / (\sum (A_e \times U_e) + 0.33nV)$$

$\sum (A_e \times U_e)$ is as follows:

Element	Area (m ²)	U Value (W/m ² K)	Ae x Ue
Walls	(10.6 x 3.6) – (5.85) = 32.31	0.27	8.72
Windows	2x1.8 + 1.25x1.8 = 5.85	2.8	16.38
Roof	0	0	0
$\sum (A_e \times U_e)$			25.1

$$A_i = 7.6 \times 3.6 = 27.36\text{m}^2$$

$$\sum (A_e \times U_e) = 25.1$$

$$V = (7.6 \times 3 \times 3.6) = 82.08 \text{ m}^3$$

n = 1, from Table A5 of BR443:2006

$$R_u = 0.52 \text{ m}^2\text{K/W}$$

Following BR443:2006 and TGD Part L, the U value is calculated as follows:

$$U = 1 / ((1/U_o) + R_u)$$

$$U = 1 / ((1/2.1) + 0.52)$$

$$U = 1.00 \text{ W/m}^2\text{K}$$

Example 3: Element Adjacent to Unheated Adjoining Building

The following example adjusts the U-value for an element adjacent to an unheated adjoining building.

For adjoining buildings it may be difficult to determine the parameters required to calculate the Ru value. The following conservative guidelines represent a reasonable approach to derive these parameters where relevant information is not available on the adjoining building:

U-values:

1. If the buildings were constructed at the same time and are of similar construction, the U-values of the elements should be based on the **original** U-values as the building being assessed.
The building being assessed may have been upgraded since original construction, however unless the BER Assessor can provide documentary evidence to support that the adjoining building was upgraded, the U-values must be based on the original construction.
2. If the adjoining building was constructed at a different time to the building being assessed, the Assessor should base the U-values on default U-values for the building age using the inference method.
3. If neither of the above options apply or if in doubt, use a conservative default of 2 W/m²K for all elements of the adjoining building. This is the default value used in the BRE U-value calculator.

Measurements:

1. The Assessor should base the estimated measurements on the information available during the site survey or other available information e.g. planning files etc. The measurements should be based on the most applicable conservative value with the Assessor commenting and keeping a record of the calculations.
2. Where access is restricted to the adjoining building, base the dimensions for the adjoining building on external dimensions.

The unit being assessed below is part of a building constructed in 1950. The walls were constructed of cavity blockwork with no insulation. The roof is metal clad with no insulation.

All the units within the building consist of unheated workshops and conditioned offices.

In order to determine the U-value of the wall between the office and adjoining building, the Assessor must determine the default U-values for the building age:

As the building was constructed in 1950 with no insulation, the default U-values as based on the NEAP Survey Guide A4.2 are:

- External Wall U-value: 1.6 W/m²K
- Roof U-value: 7.14 W/m²K
- Door U-value: 3 W/m²K
- Internal Wall U-value: 1.7 W/m²K

The adjoining unit is the same height as the unit being assessed. The external dimensions of the adjoining unit are the same as the unit being assessed. Therefore it is acceptable to use the dimensions from the unit being assessed.

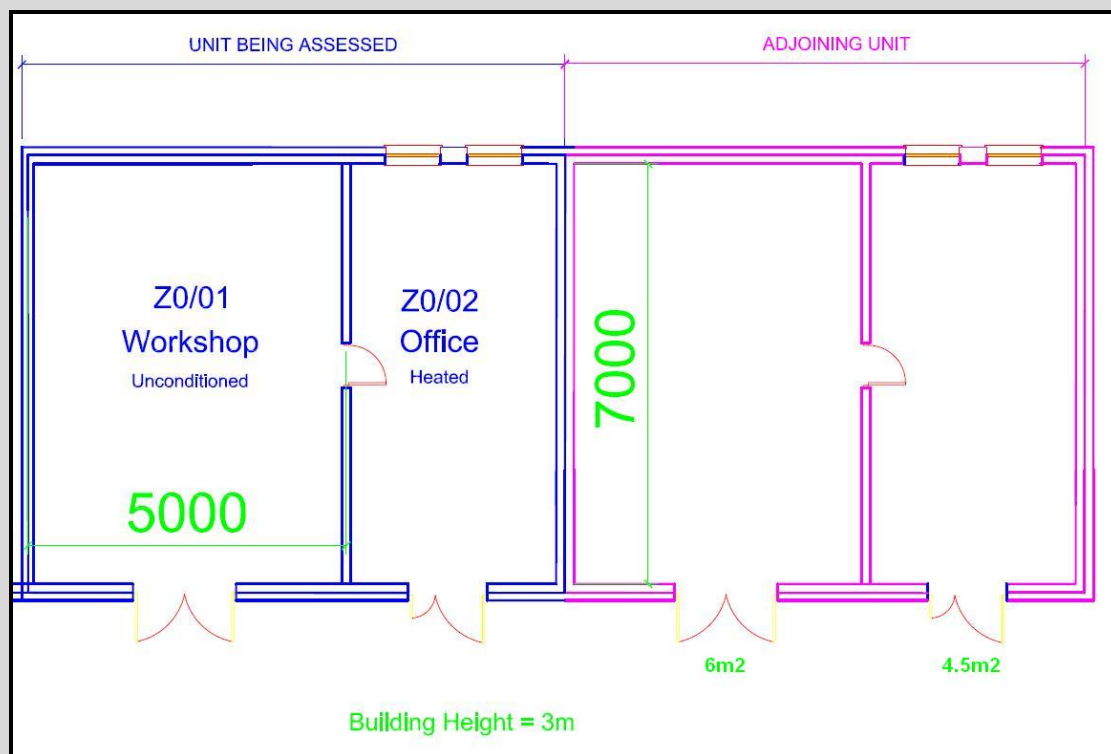

Following BR443:2006, the Ru value is calculated as follows:

$$R_u = A_i / (\sum (A_e \times U_e) + 0.33nV)$$

$\sum (A_e \times U_e)$ is as follows:

Element	Area (m ²)	U Value (W/m ² K)	Ae x Ue
Walls	$(10 \times 3) - (6) = 24$	1.6	38.4
Door	6m ²	3.0	18.0
Roof	$7 \times 5 = 35$	7.14	249.9
$\sum (A_e \times U_e)$			306.3

Note: As per Appendix A of BR 443: 2006 ground floor is omitted.

$$A_i = 7 \times 3 = 21\text{m}^2$$

$$\sum (A_e \times U_e) = 306.3$$

$$V = (5 \times 7 \times 3) = 105 \text{ m}^3$$

n = 3, default from Table A5 of BR443:2006

$$R_u = 0.0512 \text{ m}^2\text{K/W}$$

Following BR443:2006 and TGD Part L, the U value is calculated as follows:

$$U = 1 / ((1/U_0) + R_u)$$

$$U = 1 / ((1/1.7) + 0.05)$$

$$\mathbf{U = 1.56 W/m^2K}$$

3 Building Services – Shell and Core Buildings

Following a number of queries to the BER Helpdesk, here is some useful guidance on Shell and Core buildings.

Shell and Core Buildings are buildings which are assessed as bare structures without the services being installed, with the intention that the new owner or tenant will fit out the building with services appropriate for their use.

Following a recent review, guidance on the type of rating that should be published for Shell and Core Buildings has been revised from the NEAP Survey Guide A4.8 and October 2011 Technical Bulletin.

The type of rating published for Shell and Core Buildings should follow the same guidelines as any other building, namely:

- New Building – Provisional Rating: A rating published on the basis of the plans and specifications for a proposed construction.
- New Building – Final Rating : A rating published for a building where construction is complete and has not been sold or occupied previously.
- Existing Building – Final Rating: A rating published for a building where construction is complete and it has been sold or occupied previously.

For example, an office block that was constructed in 2000 and has been previously occupied should always be issued with an “Existing Building – Final” rating regardless of whether services are installed or not.

Assessors should note that this is a change to previous guidance in the October 2011 bulletin and Section A4.8 of the NEAP Survey Guide. Any certificates that were published prior to the issuing of this technical bulletin will not be penalised where previous guidance was followed. We have updated the relevant sections of the online NEAP Survey Guide and the October 2011 bulletin to reflect this change.

Zone Activity

Typically Shell & Core zones would be office or retail spaces. In these cases the Assessor should assign the appropriate activity to the zone:

Zone Type	Zone Activity
Shell & Core Office	Speculative Office
Shell & Core Retail	Speculative Retail

There may be some circumstances where these activities are not appropriate for the building type. In such cases the Assessor should select the most appropriate activity type for the building.

HVAC & Lighting System

In relation to the servicing of the building, follow guidelines set out in Appendix A4.8 of the NEAP Survey Guide.

As per the Code of Practice, BER Assessors are required to carry out a full building survey where an Existing or New Final BER certificate is being published. In the case of Shell and Core buildings this may be just verifying that no services are installed along with collecting other data such as dimensions.

If there is any material change to the data in the BER assessment such as fabric, services for heating, hot water, mechanical ventilation or air conditioning, the original BER certificate is no longer valid. This applies to all buildings – not just shell and core buildings.

4 General – Supporting Evidence for BERs

4.1 Building Owners Knowledge – Building Age

As outlined in the NEAP Survey Guide, Assessors may use the building owner's knowledge to help determine the age of the building. Recent audits have found that Assessors are obtaining verbal confirmation from the building owner and that no documentation exists to substantiate the entry.

When relying on building owners' knowledge to determine the building age, it should be retained as written confirmation from the building owner. Section 2 of the NEAP Survey Guide details other information to be requested from the building owner and provided in writing to the Assessor.

4.2 Electricity Power Factor in New Buildings

There have been a number of queries to the BER Helpdesk in relation to the use of non default power factors in new buildings. In order to substantiate the use of non default power factors in new buildings an Assessor should have one of the following:

- 1) A power factor of >0.95 can be used in a new building where an Assessor can provide adequate documentary evidence to support the installation of power factor correction equipment within the building for final certificates and the proposed installation of power factor correction equipment for provisional certificates.
- 2) A non default power factor can be used in a new building where a suitably qualified electrical engineer has produced a report detailing the proposed power factor for the building. All calculations and details in the report must correspond to the as built drawings, specifications and details for the building.

The default factor of <0.9 is used in the absence of the above information.

4.3 "Issued for Construction" drawings

Recent audits have found that Assessors are submitting "Issued for Construction" drawings to substantiate entries in New Final BER assessments.

Assessors should provide additional supporting information to confirm that the building was constructed as per the "Issued for Construction" drawings.

For example an Assessor has "Issued for Construction" drawings from the M&E consultant detailing the lighting installation. The Assessor should provide additional information to substantiate that the lighting was installed as per the "Issued for Construction" drawings. This could be for example:

- Photographs of the light fitting as installed.
- Survey Sheet detailing the light fittings as installed.

5 Quality Assurance System and Disciplinary Procedure (QADP)

SEAI have undertaken a review of the Quality Assurance System and Disciplinary Procedure (QADP) reflecting some operational changes and also feedback from BER assessors. A revised QADP has now been published at the following [link](#).

Your attention is particularly drawn to the following sections, which have been significantly amended:

2.3.3.2 Documentation and Practice Audit (With Site Inspection)

3.3.1 Audit findings and penalty points

3.3.3 Summary suspension of registration

We suggest that you take this opportunity to review the QADP and to gain a clear understanding of the obligations and implications therein. As always, we welcome any feedback you make have.

6 Audit Request Compliance

BER Assessors are required to respond to audits within 28 days from the issuing of notification of an audit request in showing compliance with the Code of Practice.

It is important to ensure that all relevant information is provided and clearly labelled when responding to an audit request. The required information should already be on file prior to the BER publication.

Assessor Name & Assessor ID

Many Assessors have submitted survey forms which did not clearly state the Assessor's name or ID in response to audit requests.

Every survey form used in a BER assessment must clearly state the Assessor's name or registration number.



Non Domestic BER Assessors – Technical Bulletin

Issue No. 1/13

May 2013

Contents:

1	Building Services – HWS Systems	2
1.1	Default instantaneous electric heaters.....	2
1.2	Identifying dedicated hot water boiler systems	2
1.3	Identifying hot water generator types	4
1.4	Assigning HWS systems to zones	5
2	Building Services – HWS Storage Systems	6
2.1	Multiple storage systems served by a single type system	6
2.2	Multiple storage systems served by a number of system types.....	7
2.3	Default insulation thickness	8
3	Building Services – HVAC Systems	10
3.1	Identifying common HVAC systems.....	10
3.2	No access to plant.....	11
3.3	Bivalent heating systems.	12
4	Building Services – Lighting	13
4.1	Identifying common lighting systems.....	13
4.2	No Lighting system present.....	14

The Non-domestic BER Technical Bulletins are archived [here](#).

This technical bulletin addresses a number of issues recently encountered by the BER audit team and Helpdesk, including:

- Defining HWS systems;
- Entering HWS Storage systems;
- Defining HVAC systems;
- Selecting the correct lighting systems.

1 Building Services – HWS Systems

Recent audits have highlighted a number of non-compliances relating to HWS systems. Here is some guidance on the methodology to be applied in each case.

1.1 Default instantaneous electric heaters

Where a **building** has no hot water system installed, follow the guidance set out in the NEAP Survey Guide A4.4:

“Where a fuel (oil/gas) is supplied to the building the HWS System:

“Dedicated Hot Water Boiler” should be selected with a fuel type based on fuel supplied to unit.

Where no fuel is supplied to the building the HWS System:

“Instantaneous Hot Water only” should be selected with a fuel type of “Grid Supplied Electricity”

HWS System Storage/ Secondary Circulation Losses: Not present”

Section 6 (example ii) of the October 2011 Technical Bulletin details how to determine the default efficiency for instantaneous electric water heaters as follows. This is based on Section 8 of the Non Domestic Building Services Compliance Guide:

When “Stand Alone Water Heater” or “Instantaneous Hot Water Only” are selected for the hot water heater the defaults are 0.7 and 0.65 respectively for non-electric fuel supplies. When electricity is selected as the fuel type the efficiency should be entered as 1:

The image displays two screenshots of the 'HWS selector' software interface. Both screenshots show the 'General' tab with the following settings: Name: HWS, Generator type: Stand-alone water heater, Fuel type: Grid Supplied Electricity, and a checkbox for 'Tick if the generator is later than 1998' which is unchecked. The question 'Do you know the effective heat generating seasonal efficiency?' is present in both. In the top screenshot, the 'Yes, seasonal efficiency is' option is selected with a value of 1, and a large red checkmark is overlaid on the left. In the bottom screenshot, the 'No, use default value' option is selected with a value of 0.7, and a large red X is overlaid on the left.

1.2 Identifying dedicated hot water boiler systems

Dedicated hot water boilers are defined in SBEM as follows: “A heat generator serving a separate hot water storage unit. It does not provide a space heating service”.

The following example demonstrates when Dedicated Hot Water Boiler should be applied in a NEAP assessment.

Dedicated Hot Water Boiler system

This schematic shows a system where **“Dedicated hot water boiler”** is the heat source for a hot water system. The boiler only serves the hot water storage system. Space heating is served by a separate boiler.

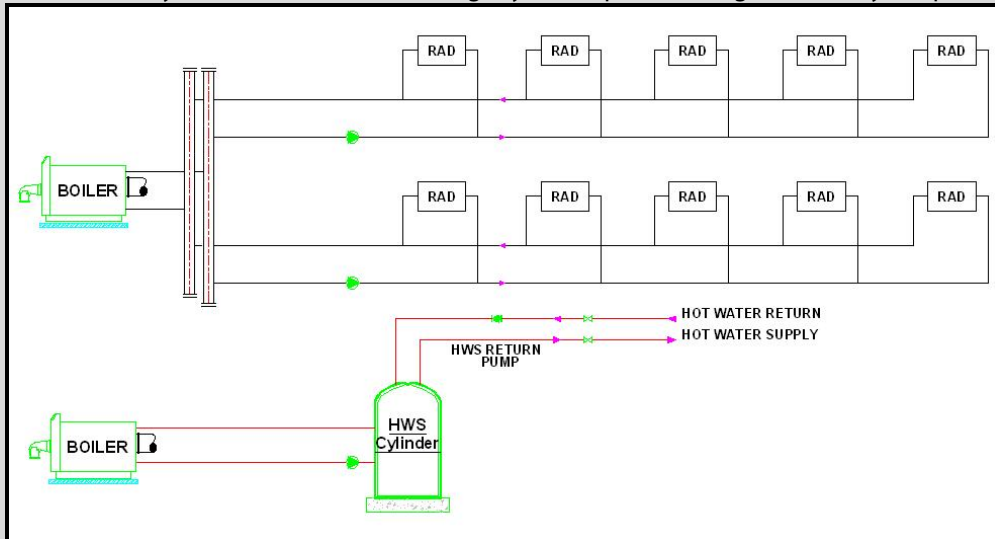

Auditors have found that Assessors are incorrectly selecting **“Dedicated hot water boiler”** when the boiler also serves the space heating system, for example the schematic below. In the case where the boiler is serving both the space heating and the hot water storage system, select **“Same as HVAC”**.

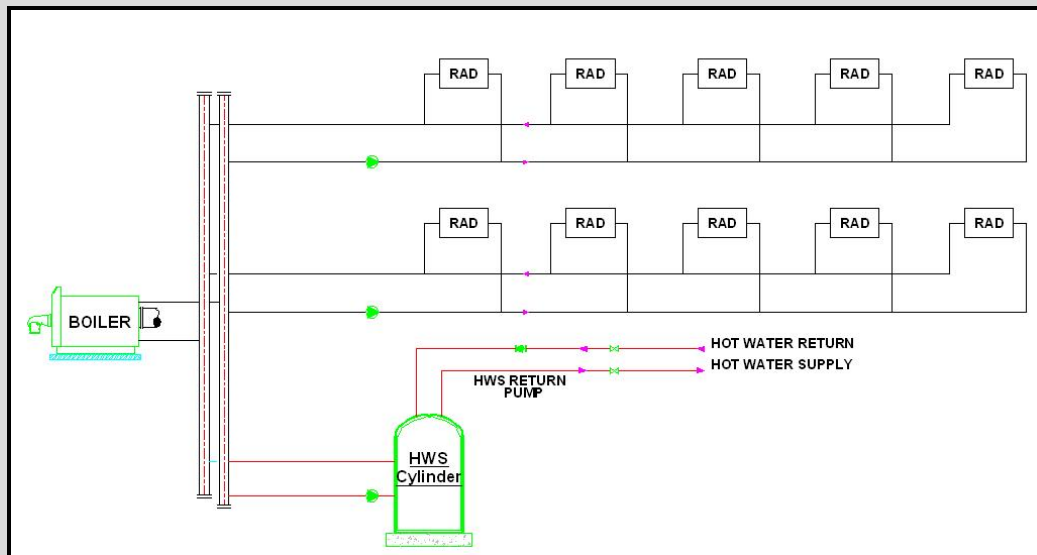

1.3 Identifying hot water generator types

The following table shows a number of generators listed on the iSBEM HWS tab:

	<p>Dedicated Hot Water Boiler: A dedicated hot water boiler as defined in SBEM as a “a heat generator serving a separate hot water storage unit. It does not provide a space heating service.”</p>
	<p>Standalone Water Heater: A standalone water heater as defined by SBEM as a “unit that combines hot water storage and a heat generator in a single unit. It does not provide a space heating service”.</p>
	<p>Instantaneous Hot Water Heater An instantaneous hot water heater as defined in SBEM is a water heater with no (or limited) storage capability. The water heater instantly heats water as it flows through the generator and does not retain water internally.</p>
	<p>Instantaneous Combi An instantaneous combi heater as defined in SBEM is a space heating boiler that also provides domestic water heating with no (or limited) storage capability.</p>

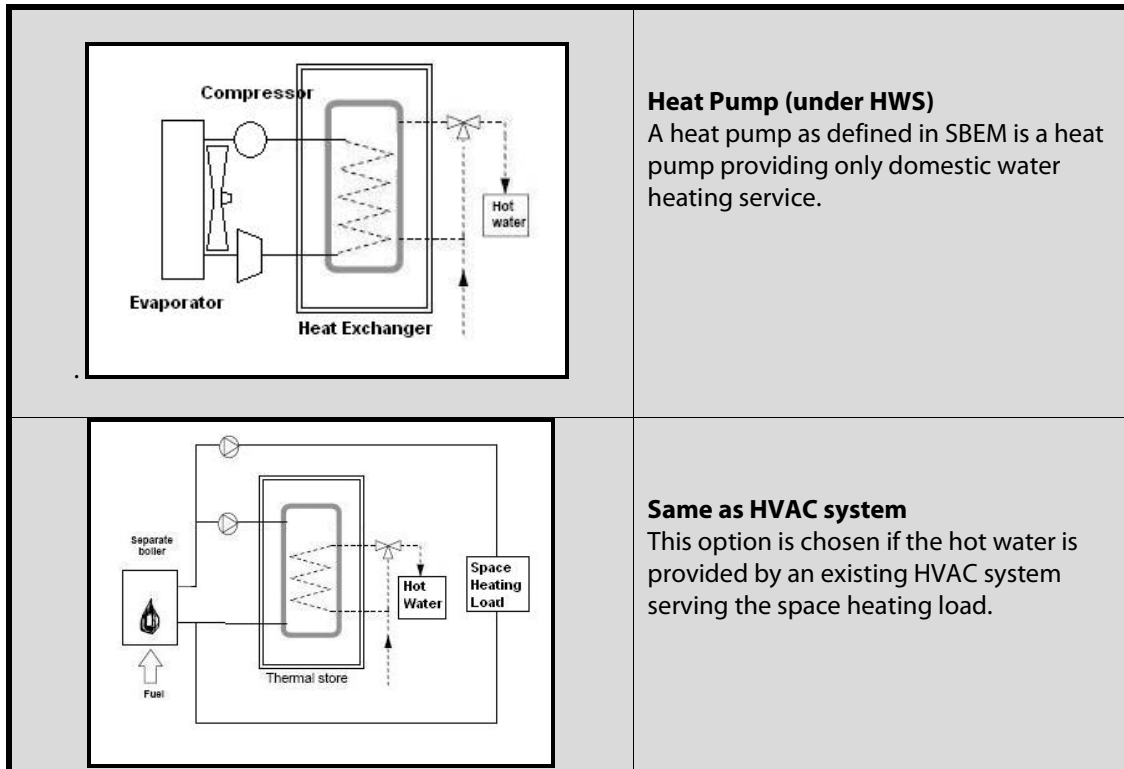

1.4 Assigning HWS systems to zones

HWS systems must be assigned correctly to zones. The iSBEM User Guide Section 7.6.8 describes when to assign a HWS to a zone. Depending on the activity, each zone will have a hot water demand. For example an office will have a hot water demand for its occupants washing hands. As stated in the iSBEM User Guide, this demand is associated with the office rather than the toilet. Therefore the office zone must be assigned with the HWS system.

The following is an example of how to correctly apply a HWS system to zones.

Assigning HWS systems to Zones

The following plan shows a HWS system supplying hot water to the toilets and tea rooms in an office unit.

The Assessor incorrectly assigned the actual HWS system (Installed HWS) to only the toilets and tea room and a default HWS (Basic HWS) to the remainder of the zones:

Zone	HWS Applied
Z0/01 Office	Basic HWS
Z0/02 Office	Basic HWS

Z0/03 Office	Basic HWS	
Z0/04 Office	Basic HWS	
Z0/05 WC	Installed HWS	
Z0/06 WC	Installed HWS	
Z0/07 WC	Installed HWS	
Z0/08 Lobby	Basic HWS	
Z0/09 Tea Room	Installed HWS	
Z0/10 Corridor	Basic HWS	

The Assessor should have assigned the actual HWS system (installed HWS) to all the zones:

Zone	HWS Applied	
Z0/01 Office	Installed HWS	
Z0/02 Office	Installed HWS	
Z0/03 Office	Installed HWS	
Z0/04 Office	Installed HWS	
Z0/05 WC	Installed HWS	
Z0/06 WC	Installed HWS	
Z0/07 WC	Installed HWS	
Z0/08 Lobby	Installed HWS	
Z0/09 Tea Room	Installed HWS	
Z0/10 Corridor	Installed HWS	

Where more than one HWS serves a building, the HWS system that is assigned to a zone is the HWS system that accounts for the majority of the HWS demand in that zone.

To identify the system that serves the majority of the HWS demand, determine what each system serves and the associated hot water demand for each system.

For example, an office zone may be served by two hot water systems, one serving an adjoining tea room and one serving the adjoining toilets and changing rooms. The specification of the units is as follows:

1) Tea Room	1.5kW Electric Instantaneous Electric Heater.
2) Toilets & Changing Rooms	30kW Gas Fired Stand Alone Water Heater with 220 litre storage.

The unit serving the toilets and changing rooms will meet the majority of the HWS demand in this instance. Therefore this system is assigned to the office zone.

2 Building Services – HWS Storage Systems

This article addresses a number of audit non compliances relating to HWS Storage systems.

2.1 Multiple storage systems served by a single type system

The following example shows how multiple storage systems should be dealt with.

The diagram below shows 4 electric water heaters (UH 1 to 4) of the same make and model with a storage capacity of 10 litres in each unit. The units were installed in 2004.

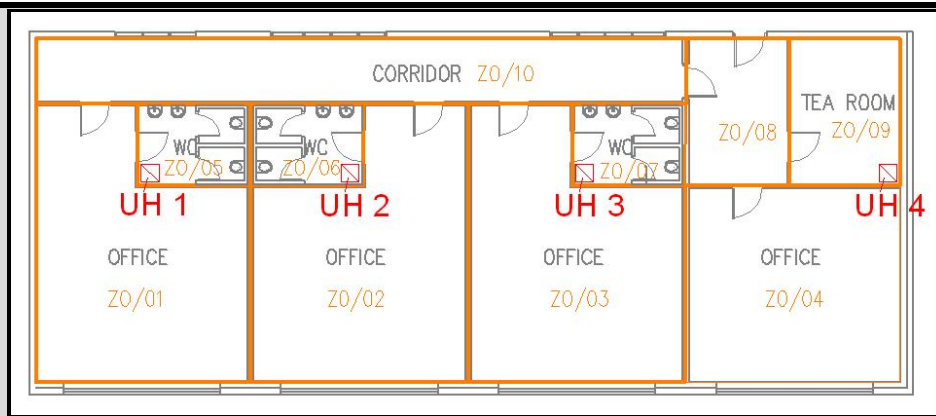

Where a combination of HWS generators act independently of each other the total storage volume should be included in SBEM. Therefore the storage volume would be entered as follows:

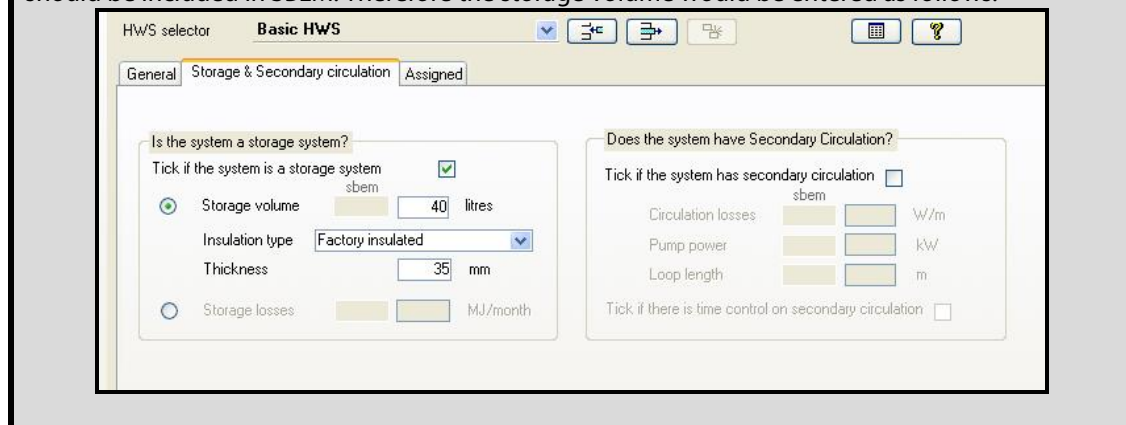

2.2 Multiple storage systems served by a number of system types

In cases where a number of HWS systems with storage capacity are present and they act simultaneously, the storage capacity should be dealt with as follows:

- 1) Where two or more HWS systems serve specific independent parts of the building, these systems should be included in SBEM and the associated storage volumes assigned to each system.

For example below shows an extension (blue) which was added to the original building (red). A new HWS system was installed to serve the extension (blue) section while the original HWS system was maintained to serve the original building (red). The two systems are entered into SBEM and assigned to the appropriate zones.

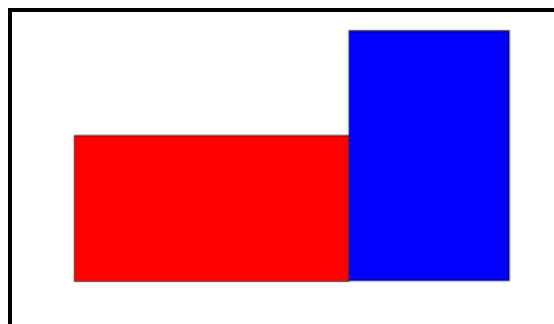

- 2) Where two or more HWS serve the same zones simultaneously, the HWS system that is assigned to the zone is the HWS system that accounts for the majority of the HWS demand in that zone. The storage capacity should account for all the storage systems. iSBEM user guide Section 7.6.3 details how to treat systems that do not work simultaneously (e.g. one of the system is installed for backup purposes).

2.3 Default insulation thickness

Assessors must follow the guidance in the survey guide regarding default storage insulation thickness. If unable to determine the actual insulation thickness on a HW storage unit, base the insulation thickness on the age of the storage unit as outlined in Section A4.4 of the NEAP Survey Guide:

Hot Water cylinder insulation if not accessible	Pre 1993: No Insulation 1994 to 1999: 25mm Factory Insulated Post 1999: 35mm Factory Insulated
---	--

If the age of the storage unit is unknown, it must be assumed that the storage unit is the same age as the building.

As an example, take a building constructed in 1950, with heating and hot water system upgraded in 2005. Where the Assessor can demonstrate the age of the hot water system using documentary evidence, they can base the insulation level on Post 1999 defaults. However, where the Assessor cannot provide documentary evidence to support the age of the hot water system, they must base the insulation on Pre-1993 levels. A sample of documentary evidence that would be acceptable includes:

- Invoices detailing the upgrade for the building
- Date on the data plate of the storage unit
- As Built Drawings dated 2005 showing the work carried out on the hot water system

Where assessors are combining the storage volume as outlined above, they must also combine the insulation thicknesses for the storage units based on a weighted volume average.

For example:

The diagram below shows 4 electric water heaters (UH 1 to 4) with a storage capacity of 10 litres in each unit. Two of the units were installed in 1990, one unit was installed in 1998 and the final unit installed in 2005. The actual insulation thicknesses cannot be identified.

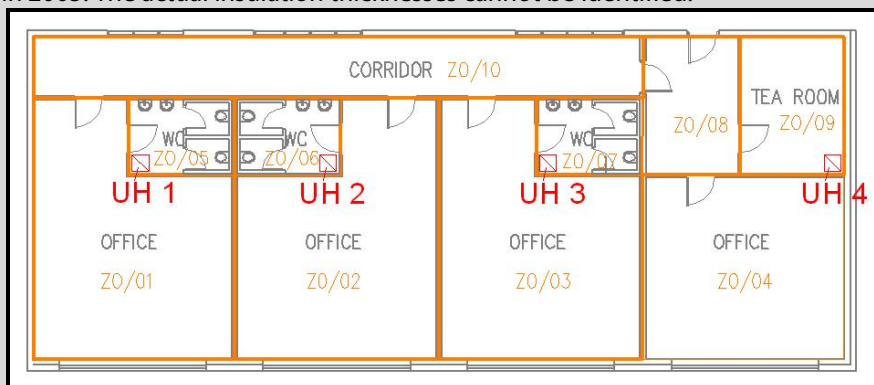

Therefore the weighted volume average is as follows:

$$\frac{20 \text{ litres} \times 0\text{mm} + 10 \text{ litres} \times 25\text{mm} + 10 \text{ litres} \times 35\text{mm}}{40 \text{ litres}} = 15\text{mm}$$

Therefore the storage volume is entered as follows:

HWS selector **Basic HWS** [dropdown] [back] [forward] [print] [calendar] [help]

General | **Storage & Secondary circulation** | Assigned

Is the system a storage system?

Tick if the system is a storage system

Storage volume: litres

Insulation type:

Thickness: mm

Storage losses: MJ/month

Does the system have Secondary Circulation?

Tick if the system has secondary circulation

Circulation losses: W/m

Pump power: kW

Loop length: m



Tick if there is time control on secondary circulation:

3 Building Services – HVAC Systems

3.1 Identifying common HVAC systems.

This article gives examples of some common HVAC systems and how they are treated in iSBEM.

	<p><i>Type:</i> Other local room heater – unfanned</p> <p><i>Heat Source:</i> Direct or storage electric heater</p> <p><i>Fuel:</i> Grid Supplied Electricity</p>
	<p><i>Type:</i> Split or Multi Split System</p> <p><i>Heat Source:</i> Heat pump (gas/oil): air source or Heat pump (electricity): air source</p> <p><i>Fuel:</i> Grid Supplied Electricity or Gas etc</p>
	<p><i>Type:</i> Central heating using water: radiators</p> <p><i>Heat Source:</i> LTHW Boiler or Heat Pump etc</p> <p><i>Fuel:</i> Grid Supplied Electricity or Gas or Oil or Biomass etc</p>

	<p><i>Type:</i> NA</p> <p><i>Heat Source:</i> NA</p> <p><i>Fuel:</i> NA</p> <p>The system is a destratification fan. It does NOT provide heating and is not entered under HVAC systems.</p> <p>However, destratification fans are included under <i>Zones/HVAC, HWS & Lighting Systems/HVAC system parameters</i> where "Are there Destratification fans in the zone?" should be ticked.</p>
	<p><i>Type:</i> Central heating using water: convectors</p> <p><i>Heat Source:</i> LTHW Boiler or Heat Pump etc</p> <p><i>Fuel:</i> Grid Supplied Electricity or Gas or Oil or Biomass etc</p>

3.2 No access to plant

Where a plant room is inaccessible on site, (for example no access to the boiler house or plant rooms containing chillers or air handling units) default data must be used. In cases where there is no plant access, it is not acceptable to confirm the plant using a letter from the client.

A couple of examples of how to select default systems are as follows:

Example 1:

An Assessor has access to the zones in a building constructed in 1960, served by radiators for heating. There is no cooling present. However, the Assessor cannot access the boiler room but has noted an oil tank outside with pipework connecting the oil tank to the boiler room. A flue is also present on the roof of the boiler room. Therefore it can be assumed that the heating system is oil fuelled.

In this case the assessor has sufficient evidence to demonstrate the system type and source of the heating, but must use the default for the efficiency of the heat source.

Type: Central heating using water: radiators
Heat Source: LTHW Boiler

Fuel Type: Oil
 Heat Generator Efficiency: 0.65 (Default for Building Age)

Example 2:

An Assessor has access to the zones in a building constructed in 1985, served by an air distribution system. The assessor cannot access the boiler room or any plant rooms. However a gas meter is present in the building. In this case the assessor is unable to determine the type of system or the sources of heating and cooling. Therefore the assessor must use a default system as outlined in the Survey Guide Section A4.3:

Type: Heating and Mechanical Cooling (HVAC System Default)
 Fuel Type: Natural Gas

Example 3:

An assessor has access to the zones in a building constructed in 1978, served by an air distribution system. The assessor cannot access the plant rooms but has determined that the air distribution system provides heating only. The assessor has found no evidence of any fuel other than electricity on site. Therefore the assessor must use a default system as outlined in the Survey Guide Section A4.3:

Type: Heating Only – Electric Resistance

3.3 Bivalent heating systems.

There have been a number of queries to the BER Helpdesk on Bivalent systems in SBEM. As per the iSBEM User Guide, a bivalent system is used where two or more types of heat sources provide heating to a zone. The efficiency of the bivalent system is based on the respective loads, efficiencies and emission factors.

The system type should be based on the predominant system. For example, the predominant system can be determined by the kW rating of each system within the zone against the running hours of each system.

If assessors are unable to determine the load profile of each system they can assume that the split between the systems is equal (for example between two systems the split is 50:50).

The following example demonstrates calculation of a bivalent system efficiency and its entry to iSBEM.

A zone is served by a central heating radiator system and air conditioning split system. The central heating system is served by a gas fired boiler with a default efficiency of 81% providing 70% of the annual heating demand. The air conditioning split system has a default COP of 2 and provides 30% of the annual heating demand.

The Bivalent system is calculated based on the following equation from the iSBEM User Guide:

$$SEff_{equivalent} = \frac{EmissionFactor_{Gas}}{\left(\frac{EmissionFactor_{Elec} \times Load_{HeatPump}}{COP_{HeatPump}} \right) + \left(\frac{EmissionFactor_{Gas} \times Load_{Boiler}}{SEff_{Boiler}} \right)}$$

The emission factors are based on Table 2 of the iSBEM User Guide (Section 2.4)

$$SEff_{equivalent} = \frac{0.203}{\left(\frac{0.643 \times 0.3}{2} \right) + \left(\frac{0.203 \times 0.7}{0.81} \right)}$$

= 0.747

The HVAC system is entered as follows:

Name	Office		
Type	Split or multi-split system		
Heating system			
Heat source	LTHW boiler		
Fuel type	Natural Gas		
Cooling system			
Pack Chiller	Default chiller		
Generator type	Heat pump (electric)		
Ventilation		Heat recovery	
		Do you know the Heat Rec. seasonal efficiency?	
		<input type="radio"/> No, use the default ratio <input checked="" type="radio"/> Yes, Heat Rec. seasonal eff. is: 0.747 ratio	
For this HVAC system, Ventilation is defined at zone level			

The Bivalent Efficiency calculated is entered under the Heating Tab “Effective Heat Generating Seasonal Efficiency” as follows:

Heating system	
Heat source	LTHW boiler
Fuel type	Natural Gas
<input type="checkbox"/> Tick if this HVAC system uses variable speed pumps	
Does it qualify for UK ECAs?	
Not in the ECA list	
Was it installed in or after 1998?	
<input type="radio"/> No <input checked="" type="radio"/> Yes	
Do you know the effective heat generating seasonal efficiency?	
<input type="radio"/> No, use default value 0.81 <input checked="" type="radio"/> Yes, seasonal efficiency is: 0.747	
Do you know the generator radiant efficiency?	
<input checked="" type="radio"/> No, use default value 0.4 <input type="radio"/> Yes, radiant efficiency is: 0.4	

4 Building Services – Lighting

4.1 Identifying common lighting systems.

Auditors have found that lighting systems are commonly entered incorrectly into SBEM.

The following gives examples of various lighting systems:



	<p>Compact Fluorescents</p>
	<p>Tubular Fluorescents</p> <p>T5: 16mm diameter T8: 26mm diameter T12: 38mm diameter</p>
	<p>Metal Halide</p>

The SEAI website provides a number of lighting guides. These are useful in identifying different lighting systems: http://www.seai.ie/Your_Business/Technology/Buildings/Lighting.html

4.2 No Lighting system present.

Where no lighting system is present or an Assessor is unable to identify the lighting system, follow the guidance within the SBEM User Guide and NEAP Survey Guide and select the following:

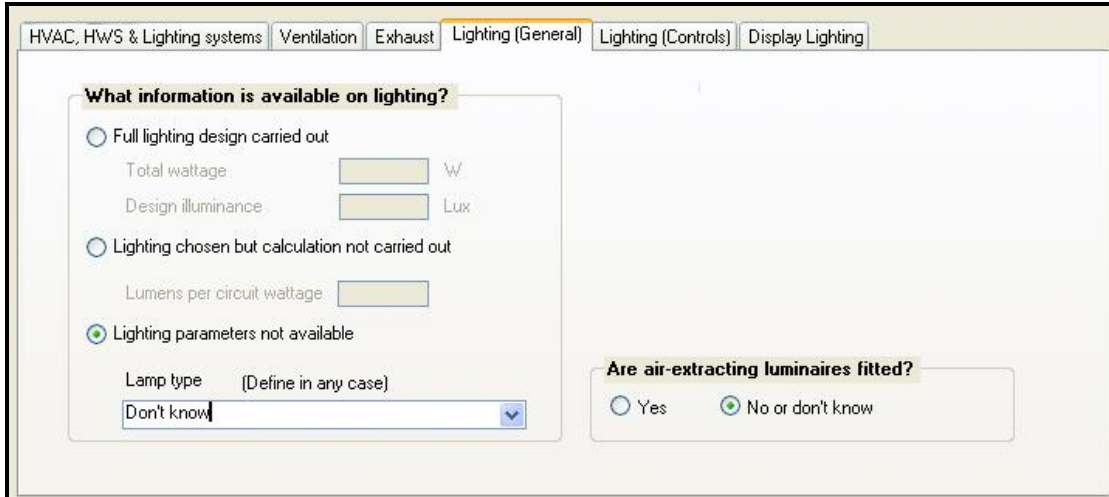

HVAC, HWS & Lighting systems | Ventilation | Exhaust | **Lighting (General)** | Lighting (Controls) | Display Lighting

What information is available on lighting?

Full lighting design carried out
 Total wattage: W
 Design illuminance: Lux

Lighting chosen but calculation not carried out
 Lumens per circuit wattage:

Lighting parameters not available
 Lamp type (Define in any case)

Are air-extracting luminaires fitted?
 Yes No or don't know



Non Domestic BER Assessors – Technical Bulletin

Issue No. 1/14

February 2014

Contents:

1	General – Updated Survey Guide.....	2
2	General – Common / Landlord Areas requiring BERs	2
3	Project Database – Further Examples of Construction Types	4
4	Domestic Accommodation Adjoining Non-Domestic BER	5
5	Geometry – Checking iSBEM Inputs	7
6	Building Services – Heating / Cooling & HWS Efficiencies.....	7
6.1	Correct entry of efficiency values	7
6.2	Correct entry SEER and EER.....	8
6.3	Correct entry of direct or storage electric heaters	11
6.4	Correct entry of boiler efficiency from test cert / ECA data.....	12
6.5	Correct entry of Hot Water Generator efficiency	12
7	Building Services – Lighting and Lighting Controls	14
7.1	Identification and proof for occupancy & photoelectric sensors.....	14
7.2	Entering a full lighting design.....	15
7.3	Identification of Metal Halide, Tungsten Lamps & CFL Lamps.....	16
7.4	Non Functioning Lighting	18

The Non-domestic BER Technical Bulletins are archived [here](#).

This technical bulletin addresses a number of issues recently encountered by the BER audit team and Helpdesk, including:

- Information on the revised Survey Guide and associated guidance
- Common / Landlord Areas requiring BERs
- Examples of Construction types in the Project Database
- Non-domestic BER adjoining domestic premises.
- Assistance in checking iSBEM geometry inputs
- Entering Heating / Cooling and HWS Efficiencies
- Identifying and entering Lighting Controls and Full Lighting design entry

1 General – Updated Survey Guide

SEAI has updated the Non-Domestic Building Energy Rating Survey Guide to Version 1.2. The update clarifies a number of items identified at audit and the BER Helpdesk. In addition the new guidance incorporates items from previous technical bulletins which will also assist assessors.

The NEAP Survey Guide is available [here](#). Page 3 of the Survey Guide (“Key Changes and Additions”) gives a detailed list of changes made since the previous published version 1.1.

We have also published a Microsoft Excel spreadsheet and associated instructional document to assist assessors in carrying out U-value adjustments for heat loss elements adjoining unheated spaces using the relevant standards and guidance [here](#). This is aligned to Appendix 8 of the NEAP Survey Guide.

We have made minor amendments to the April 2012 and October 2012 technical bulletins to maintain alignment with the NEAP Survey Guide and FAQ updates. The amendments are highlighted in red font in those bulletins [here](#).

2 General – Common / Landlord Areas requiring BERs

A number of BER Assessors have asked the BER Helpdesk for clarification on treatment of common or shared areas in larger buildings such as apartment blocks.

The BER(s) should reflect the building(s) or parts of building(s) offered for sale or rent. If there are two units with the same construction, HVAC, lighting and activities then the following options are available regardless of the number of MPRNs present:

- 1) BER to include two units and common areas,
- Or
- 2) One BER for unit one, One BER for unit two and one BER for the common areas (3 BERs).

Please see the following example showing how option 2 is addressed.

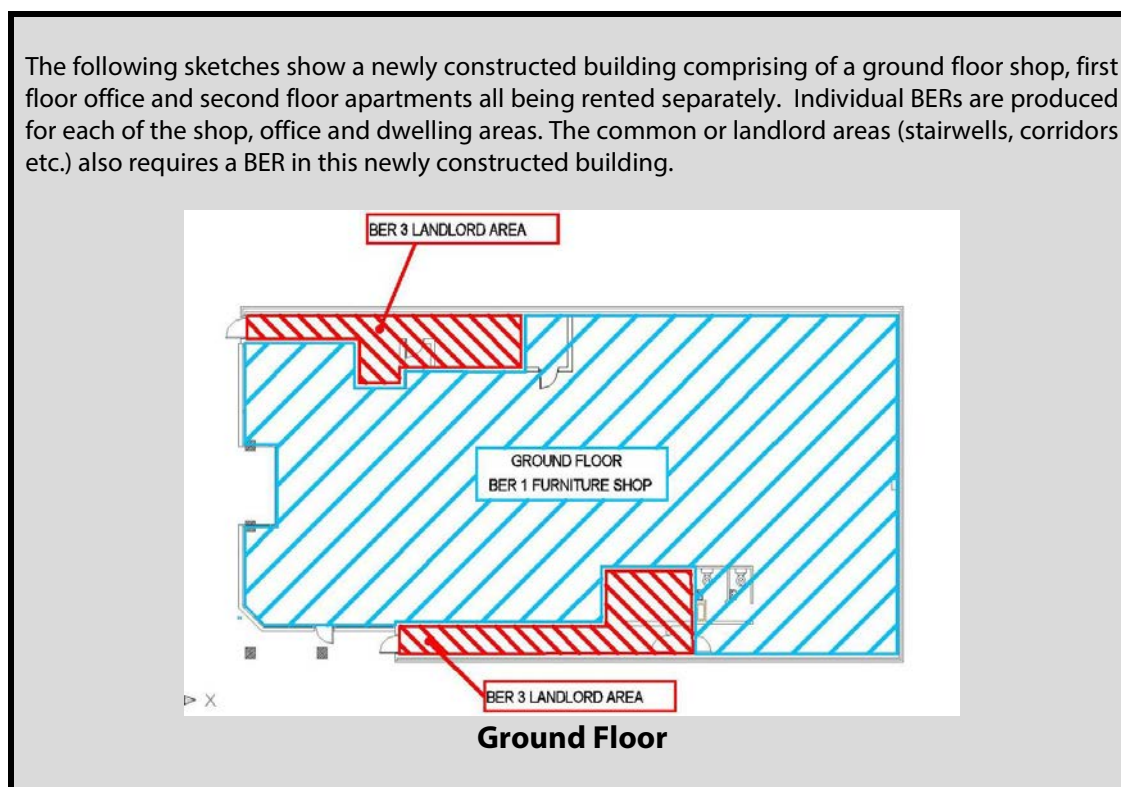

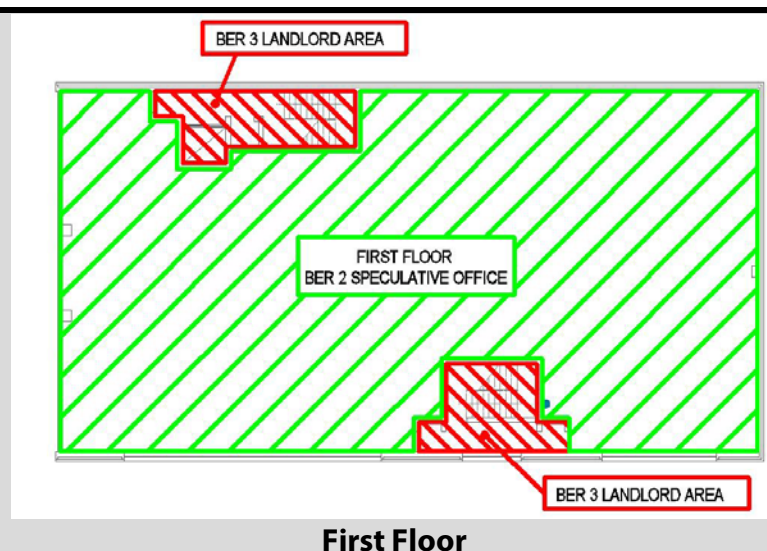
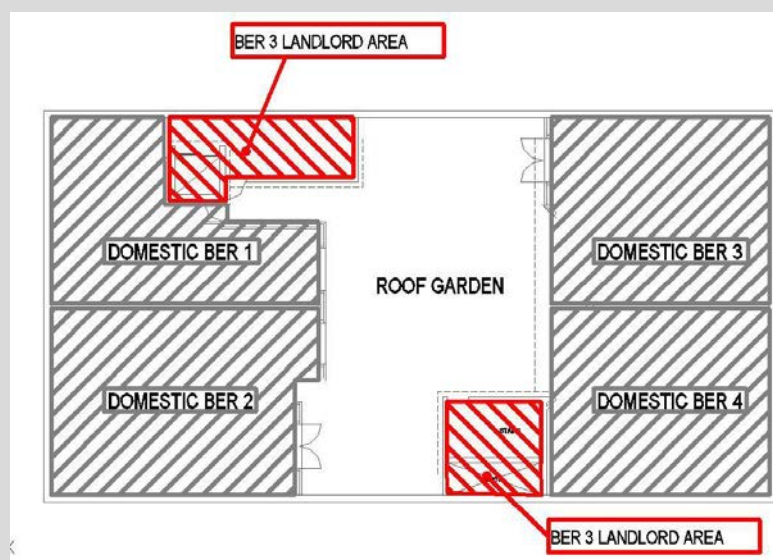
**First Floor****Second Floor**

The furniture shop and office BERs are carried out in iSBEM in the usual way. The Domestic BERs on the second floor are carried out using DEAP.

“BER 3”, covering the landlord areas, consists of unheated spaces, in this case enclosed corridors, stairways and a lift. If it happened that these particular unheated areas were part of a BER along with other heated spaces, no red ! would be displayed when “zones without HVAC” were selected and they would be left as such.

However, none of the activities under BER 3 are heated (nor are they flagged by iSBEM as requiring heating). Therefore A4.9 “Unheated Buildings” in the NEAP Survey Guide applies. As stated in NEAP survey Guide A4.9:

“A BER assessment is not required for the following unheated building types:

- an industrial building not intended for human occupancy over extended periods and where the installed heating capacity does not exceed 10 W/m²; or
- a non-residential agricultural building where the installed heating capacity does not exceed 10 W/m²

However if the building is unheated and does not comply with the above guidelines, a BER assessment is required.”

The common areas require a BER. However SBEM requires at least one HVAC system to calculate a rating and so a HVAC system will need to be applied to these zones. NEAP Survey Guide A4.9 says: “When carrying out a BER on an unheated building, base the heating system on the notional

building’s heating system and apply it to all zones within the building. For the purpose of this guide, an unheated building is defined as a building that has been fitted out with other services such as lighting, hot water, mechanical ventilation etc but has no heating system installed or specified in iSBEM.”

In this instance, the example “ Notional building system efficiency example” under Section 1.1 of the [October 2012 Technical Bulletin](#) is followed to create a heating system for the unheated premises in BER 3. Entering the notional building’s heating system means that the BER is not benefitting or being penalised for having no heating system.

Create a heating system with the type “Central heating using water: radiators”. Assign Natural Gas to the fuel type and allow for the HVAC system to use Variable Speed pumps. Set the effective heat generating seasonal efficiency to 0.78 and check the BRIRL file as per October 2012 Bulletin. This system is applied to all zones in the BER 3 for common areas (all of which are unheated in this instance).

As an aside, if one of the zones in BER 3 had heating installed, then that heating system is assigned to that zone, and the remaining corridor/stairwell are specified as unheated in iSBEM (as per NEAP Survey Guide A7.2 flowchart). A4.9 would not be followed in this instance.

Furthermore, if one of the other premises that would typically require heating (e.g. the office in BER 2) was unheated, then A4.3 in the survey guide would be followed (in BER 2) to derive a default heating system rather than A4.9.

3 Project Database – Further Examples of Construction Types

The NEAP Survey guide section A4.2 provides guidance on entering some common construction types. The following article illustrates further examples.

Example 1: External Wall constructed pre 1994

The building was constructed in 1986 with a brick wall type construction. The walls are known to be cavity walls but there are no details on insulation. External walls constructed pre 1994 are assumed to be uninsulated unless proven otherwise as detailed in NEAP Survey Guide A4.1.

Following the guidance in Section A4.2 the Assessor uses “Help with inference procedures” to select the following uninsulated wall:

U-value	<input type="text" value="1.6"/>	W/m2K	Sector	<input type="text" value="Office"/>
K _m	<input type="text" value="172"/>	kJ/m2K	Building Reg Comp.	<input type="text" value="no date, uninsulated"/>
<small>Note that this value was called Cm in previous versions</small>			General Description	<input type="text" value="Cavity wall, bricks/blocks"/>

“No date, uninsulated” is chosen. It is assumed that no insulation is present.

Example 2: External Wall constructed pre 1994

The building was constructed in 1989 with a brick wall type construction. The walls are proven to be cavity walls with insulation, although exact insulation details are not available.

U-value	<input type="text" value="1"/>	W/m2K	Sector	<input type="text" value="Office"/>
K _m	<input type="text" value="123"/>	kJ/m2K	Building Reg Comp.	<input type="text" value="Republic of Ireland (pre 1991)"/>
<small>Note that this value was called Cm in previous versions</small>			General Description	<input type="text" value="Cavity wall, bricks/blocks"/>

“Republic of Ireland pre 1991” is chosen as it is known the walls are from that era and have some insulation.

Example 3: Internal Floor connected to unheated adjoining space of a store room below.

Floor connects to unheated space rather than external ground (e.g. basement, store room etc.)

Note that using the library, the choices for internal floor are “Intermediate floor (floor side, timber)” and “Internal concrete floor (with conditioned space below)”. Select the element that best matches the construction type observed on site. Review Section 8 of the NEAP Survey Guide to evaluate the requirement for U value adjustments for heat loss elements adjoining unheated spaces.

In cases where it is not clear which default applies or there is more than one applicable option, the most conservative applicable option (resulting in higher energy usage) is chosen, unless proven otherwise.

4 Domestic Accommodation Adjoining Non-Domestic BER

The matrices in NEAP Survey Guide Appendix 8 assist assessors in selecting the correct “connect to” entry for a variety of building types. The helpdesk has received further queries regarding domestic activities adjoining commercial buildings.

Example : Comparing heating schedule of a dwelling to an office

The [April 2012 Technical Bulletin](#), Section 4, details how to access the NCM databases to compare the temperatures and occupancy hours of one building activity against another. Following the procedure in the Technical Bulletin the following can be produced for a dwelling and an office:

Hours	Temperature
0 to 1	12
1 to 2	12
2 to 3	12
3 to 4	12
4 to 5	12
5 to 6	18
6 to 7	18
7 to 8	18
8 to 9	18
9 to 10	12
10 to 11	12
11 to 12	12
12 to 13	12
13 to 14	12
14 to 15	12
15 to 16	12
16 to 17	12
17 to 18	18
18 to 19	18
19 to 20	18
20 to 21	18
21 to 22	18
22 to 23	18
23 to 24	18

The screenshot shows the 'Activity Database' window with the 'Daily Schedules' tab selected. The 'Object selector' is set to 'Office_SpecOff_Heat_Wkdy'. The 'General' tab is active, showing the following details:

- Name:** Office_SpecOff_Heat_Wkdy
- Type:** TEMPERATURE
- Category:** TEMPERATURE SET POINTS
- Source:** CIBSE A
- Description:** Building: OFFICE Area: OPEN PLAN OFFICE Weekday Daily Heating setpoint schedule (Automatically imported)

The 'Hours' section contains a table of temperature setpoints for each hour of the day:

Hours	Temperature (°C)
0 to 1	12
1 to 2	12
2 to 3	12
3 to 4	12
4 to 5	12
5 to 6	12
6 to 7	22
7 to 8	22
8 to 9	22
9 to 10	22
10 to 11	22
11 to 12	22
12 to 13	22
13 to 14	22
14 to 15	22
15 to 16	22
16 to 17	22
17 to 18	22
18 to 19	22
19 to 20	12
20 to 21	12
21 to 22	12
22 to 23	12
23 to 24	12

Additional options include a 'Shortcut to fill hours' section with 'From', 'To', and 'Value' dropdowns, an 'Apply' button, and a checkbox for 'tick if it is for holiday'.

At the bottom, the record number is 5806 of 7553, and there is a search bar.

Comparing the two screen shots, it can be seen that for Monday – Friday the domestic space is heated to 18°C between the hours of 05:00 – 09:00 and 17:00 – 24:00. The Speculative office space is heated to 22 °C between the hours of 06:00 – 19:00.

Appendix 8 of the NEAP Survey Guide details the rules whereby a space can be considered as connected to a heated or unheated space. These two zones are heated to a similar temperature (+/-5 °C) but the dwelling does not meet the requirement for this condition for 90% or more of the duration of the office’s heating periods.

Therefore the domestic space is considered to be an UNHEATED ADJOINING SPACE when assessing the speculative office space.

5 Geometry – Checking iSBEM Inputs

Some assessors have expressed concern that it is difficult to see what has been entered into iSBEM in relation to wall areas, U values and orientation. The output report produced by SBEM is useful for checking the geometry entries. The relevant file has a ".sim" extension and is located in the same folder containing the .nct and .xml files.

The file can be opened using MS Excel by changing the file extension by adding .csv. It now has the extension ".sim.csv". This report gives a range of information on the completed assessment including details of entered external areas, U-values and some other data. Towards the end of the file there is a breakdown of energy use both by fuel type and end use for both the whole project and for each HVAC system.

My Building.nct	NCT File	1,088 KB	27/11/2013 12:32
My Building_sim.ovh	OVH File	2 KB	27/11/2013 12:31
My Building_sim	SIM File	53 KB	27/11/2013 12:31
My Building_not.sim	SIM File	48 KB	27/11/2013 12:31
My Building_ref.sim	SIM File	48 KB	27/11/2013 12:31

The screenshot above lists the files that are present after running an iSBEM calculation, listed by file type.

My Building.nct	NCT File	1,088 KB
My Building_sim.ovh	OVH File	2 KB
My Building_sim.csv	SIM File	53 KB
My Building_not.sim	SIM File	48 KB
My Building_ref.sim	SIM File	48 KB

The screen shot above shows the file “My Building.sim” being changed to “My Building.sim.csv” so that it can be opened in MS Excel. The output produced is useful but not comprehensive so an assessor will still be required to check other inputs using their usual methodologies as before.

6 Building Services – Heating / Cooling & HWS Efficiencies

The following sections cover a number of key areas relating to correct identification of heating system efficiencies.

6.1 Correct entry of efficiency values

The [October 2011 Technical Bulletin](#) Section 6 (example i) discusses entry of seasonal efficiencies. When entering a non-default heat generating efficiency always enter the efficiency as a decimal 0.## rather than ##%.

In the screenshot above the right hand entry of 85 results in a boiler efficiency of 8500% instead of the intended 85% produced by the left hand entry. The right hand entry gives an incorrect appliance energy demand (1% of the correct figure) and will result in a rating being highly inaccurate. This guidance is also applicable to a number of other entries such as Air Conditioning and Hot Water System efficiencies.

In general when carrying out BER assessments it is recommended that the Assessor examines the “Ratings” tab before publishing. Errors can be identified by comparing the notional values to the actual values as well as looking at the overall rating. For example if the building is without extraordinarily good or bad insulation, heating systems etc, the different energy uses (heating, cooling, auxiliary, lighting and hot water) are likely

to be of the same order of magnitude as the notional building. Note however that the notional building has cooling regardless of the presence of a cooling system in the actual building.

In the example below, the user had incorrectly entered heating as a percentage rather than a fraction. The actual heating demand as calculated (1.68) is several orders of magnitude lower than the notional building heat demand. This suggests a significant error in the data entered by the Assessor (in this case, 8500% heating system efficiency).

	Heating	Cooling	Auxiliary	Lighting	Hot Water	Total	
Actual	1.68	0	10.73	88.4	0.72	101.53	kWh/m ² /yr
Reference	74.33	0	4.81	33.91	112.26	225.31	kWh/m ² /yr
Notional	74.33	34.66	3.34	33.91	112.26	258.52	kWh/m ² /yr

6.2 Correct entry SEER and EER

In the following examples, a split system has been identified on site and the Assessor wishes to obtain acceptable data for use in SBEM. This example presents some of the means of obtaining acceptable non default data. Sections 6.1 and 7 of the NEAP Survey Guide provide further detail on acceptable sources of data.

Using the Eurovent Website

The model is a Daikin ARXN25L / ATXN25L Split Unit



- (1) Go to the website: <http://www.eurovent-certification.com/>.
- (2) Click on certified products on the top right of the screen and select "Access by trade name".

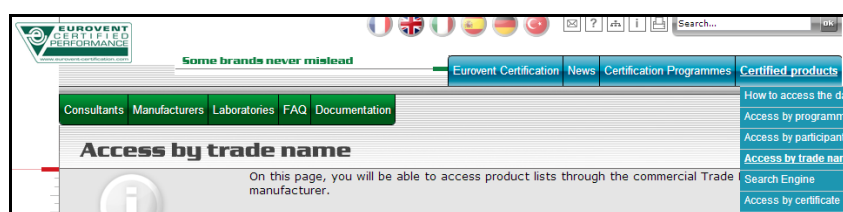

- (3) Select the manufacturer: in this case Daikin Europe N.V., then select "comfort air conditioners".
- (4) At this point there is a subcategory. Select *Comfort Air Conditioners / up to 12 kW / Air cooled / Split* as the output is 2.5kW based on the data sticker on the unit.
- (5) Select the installed appliance with the associated EER. As per the NEAP Survey Guide, Eurovent data can be used for ND assessments provided Eurovent says that that data was derived using the standards from the non-domestic compliance guide.

Range : ARXN Diploma Nr. : 94.01.087																				
Model	Cooling (-)					Heating (-)											Heating for clin			
	Pdesignic [kW]	SEER	SEER Class	Qce [kWh/y]	EER @+35	Pdesignh [kW]	SCOP	SCOP Class	Qhe [kWh/y]	Tbiv [°C]	Ph @Tbiv [kW]	COP @Tbiv	TOL [°C]	Ph @TOL [kW]	COP @TOL	Ph @+7 [kW]	COP @+7	SCOP c	SCOP Class c	Qhe c [kWh]
ARXN35L / ATXN35L	3,32	5,48	A	213	3,22	2,35	3,81	A	864	-7	2,08	2,35	-14	1,73	1,69	3,50	3,61	-	5,00	-
ARXN25L / ATXN25L	2,52	5,29	A	167	3,21	1,91	3,62	A	740	-7	1,69	2,36	-14	1,59	1,55	2,80	3,61	-	5,00	-

- (6) This appliance is categorised under “AC1: comfort units with cooling capacity up to 12 kW”.
- (7) Go to the rules for that technology on Eurovent [here](#) (follow “Certification Programmes -> Programme Descriptions”). The Performance Testing section under “Comfort Air Conditioners (AC)” shows that the data is derived using EN14511. This is the relevant standard in Section 9 of the [ND compliance guide](#). However, standard EN 14511 does not address seasonal COP or EER. The technical department of Eurovent have confirmed to SEAI that the SCOP and SEER are calculated in compliance with EN 14511 and EN 14825:2012. EN 14825:2012 deals specifically with calculating seasonal performance of air conditioners and heat pumps and was published after the Non Domestic Building Services Compliance Guide 2010. EN 14825 references EN 14511. As En14511 is the standard required in the ND Compliance Guide, EN14825 data can be used for NEAP assessments for SCOP and SEER.
- (8) Perform any adjustments as necessary to the EER using the ND Building Services Compliance Guide.
- (9) Enter the values as a fraction rather than a percentage in iSBEM. For example, a 321% efficient appliance is entered as “3.21”. The entries in SBEM are as follows:
 - EER = 3.21, in compliance with EN 14511 as referenced in the ND compliance guide.
 - SEER = 5.29, in compliance with EN 14511 as referenced in the ND compliance guide and EN 14825:2012 which references EN 14511.
 - SCOP = (Seasonal efficiency) is 3.62 in compliance with EN 14511 as referenced in the ND compliance guide and EN 14825:2012 which references EN 14511.

Using the ECA /ETL Website

The model is a Panasonic UK Ltd KIT-100PU1E5



- (1) Go to the [ECA/ETL](#) website.
- (2) Click on “The Energy Technology Product List” on the left of the screen.
- (3) Fill in the search fields. Enter the model “KIT-100PU1E5” in the model number field
- (4) Review the [Eligibility Criteria](#) on the ECA/ETL website against the standards referenced in the Non Domestic Compliance Guide. Note: The test standards referenced in calculating the seasonal performance is EN 14825:2012. EN14825 data can be used for NEAP assessments as outlined above.
- (5) Enter the values as a fraction rather than a percentage in iSBEM. The entries in SBEM are as follows:

- EER = default, as it is not provided on the ECA/ETL website for this particular product.¹
- SEER = 6.6, as it is compliant with the relevant standard (EN14825, referencing En14511).
- SCOP = 4.2 as it is compliant with the relevant standard (EN14825, referencing En14511).

Features	
Name	Value
Does it provide cooling?	Yes
Is rated cooling capacity >12kW?	No: <=12kW
Cooling capacity 100% (<=12kW) (kW)	10
Cooling capacity 100% (>12kW) (kW)	
Cooling EER (100% capacity)	
Cooling SEER (across range of connected capacities)	6.6
Heating capacity 100% (kW)	11.2
Heating CoP (100% capacity)	
Heating SCOP (across range of connected capacities) (heating season: Average)	4.2
Indoor Unit List	
Data provided	
Is product CE marked	

Entering into iSBEM

Name	Air Conditioner
Type	Split or multi-split system
Heating system	
Heat source	Heat pump (electric): air source
Fuel type	Grid Supplied Electricity
Cooling system	
Pack Chiller	Default chiller
Generator type	Heat pump (electric)
Ventilation	
Heat recovery	
Do you know the Heat Rec. seasonal efficiency?	
<input checked="" type="radio"/> No, use the default ratio <input type="radio"/> Yes, Heat Rec. seasonal eff. is: <input type="text"/> ratio	
For this HVAC system, Ventilation is defined at zone level	

Note that the EER figure has been entered as a default value as we did not obtain an EER value from ECA/ETL.

¹ Note that if an EER value is provided on the ECA/ETL website, this can be used in NEAP assessments. ECA/ETL derives EER from EN14511.

Global and Defaults HVAC systems HWS SES PVS Wind generators Zones

Record selector **Air Conditioner**

General Heating Cooling System Adjustment Metering Provision System Controls Zone Summary

Heating system

Heat source: Heat pump (electric): air source

Fuel type: Grid Supplied Electricity

Tick if this HVAC system uses variable speed pumps

Does it qualify for UK ECAs?

ECA list (uplift in 2006)

Do you know the effective heat generating seasonal efficiency?

No, use default value 2.73

Yes, seasonal efficiency is 4.2

Do you know the generator radiant efficiency?

No, use default value 0.4

Yes, radiant efficiency is 0.4

Global and Defaults HVAC systems HWS SES PVS Wind generators Zones

Record selector **Split AC Sanyo**

General Heating Cooling System Adjustment Metering Provision System Controls Zone Summary

Cooling system

Pack chiller: Default chiller

Generator type: Heat pump (electric)

Generator kW:

Fuel type: Grid Supplied Electricity

Does it qualify for UK ECAs?

Tick, if this HVAC system has mixed mode operation strategy

Do you know the generator seasonal energy efficiency ratio (SEER)?

No, use default value 2

Yes, seasonal EER is: 6.6

Do you know the generator nominal energy efficiency ratio (EER)?

No, use default value 2.5

Yes, EER is:

Record: 1 of 2 Unfiltered Search

6.3 Correct entry of direct or storage electric heaters

When direct acting or storage electric heaters are found in a building they are defined using the HVAC System tabs as shown below.

Global and Defaults HVAC systems HWS SES PVS Wind generators Zones

Record selector **Electric Heaters**

General Heating Cooling System Adjustment Metering Provision System Controls Zone Summary

Name: Electric Heaters

Type: Other local room heater - unfanned

Heating system

Heat source: Direct or storage electric heater

Fuel type: Grid Supplied Electricity

Ventilation

Heat recovery:

Do you know the Heat Rec. seasonal efficiency?

Note that the type can be chosen as “Other local room heater – unfanned” OR “Other local room heater - fanned”, depending what is on site. In addition, for Heat Source, select “Direct or storage electric heater”. **DO NOT USE** “Room Heater” for electric heating.

If entered correctly the Heating Sub tab will be as shown below. Note the efficiency is 1:

The screenshot shows a software interface for configuring an electric heater. The 'Record selector' is set to 'Electric Heaters'. Under the 'Heating system' section, the 'Heat source' is 'Direct or storage electric heater' and the 'Fuel type' is 'Grid Supplied Electricity'. There is a checkbox for 'Tick if this HVAC system uses variable speed pumps' which is unchecked. Below this, there is a question: 'Do you know the effective heat generating seasonal efficiency?'. The 'No, use default value' option is selected, and the value '1' is entered in the adjacent field. A large red checkmark is overlaid on the right side of the form, indicating that the configuration is correct.

Use of “Room Heater” in place of “Direct or storage electric heater” will produce the incorrect value of 0.7 for efficiency having a large impact on the rating.

Please refer to the Non-Domestic Building Services Compliance Guide Section 7 for details on electrical efficiency values.

Note that the default “Heating Only Electrical Resistance” must **not** be used to describe installed direct or storage electric heaters. This type of system is only used as a default system as described in Section A4.3 of the NEAP Survey Guide.

6.4 Correct entry of boiler efficiency from test cert / ECA data

The procedure for entering boiler efficiency as derived from the use of ECA listed data is detailed in Section 7 of the [April 2012 Technical Bulletin](#).

Non-default efficiency values must be calculated in as per the [Non-Domestic Building Services Compliance Guide](#). Refer to Appendix 5 of the NEAP Survey Guide for examples of how the Compliance Guide is used. Refer to the [Non-Domestic Building Services Compliance Guide](#) Table 8 to determine if credits apply to the heating efficiency of the system as installed in the building being assessed. Guidance on acceptable sources for Non-default efficiencies is provided in Section 6.1 of the NEAP Survey Guide.

6.5 Correct entry of Hot Water Generator efficiency

The topic of electric water heating efficiency is detailed in [the October 2011 Technical Bulletin](#) Section 6 (example ii) and the [May 2013 Technical Bulletin](#) Section 1.1.

For water heating using direct electricity the efficiency **must be changed** from the initial default value to a value of 1.0. This is based on Table 27 in Section 8 of the Non Domestic Building Services Compliance Guide. Incorrect use of the default will result in a 30-35% error in the water heating energy demand and can cause a significant error in the final BER grade.

When “Stand Alone Water Heater” or “Instantaneous Hot Water Only” is selected as the hot water heater the defaults are 0.7 and 0.65 respectively for non-electric fuel supplies. When electricity is selected as the fuel type for these systems, the efficiency must be entered as 1:

HWS selector HWS

General Storage & Secondary circulation Assigned

Name HWS

Generator type Stand-alone water heater

Tick if the generator is later than 1998

Fuel type Grid Supplied Electricity

Do you know the effective heat generating seasonal efficiency?

No, use default value 0.7

Yes, seasonal efficiency is 1

HWS selector HWS

General Storage & Secondary circulation Assigned

Name HWS

Generator type Stand-alone water heater

Tick if the generator is later than 1998

Fuel type Grid Supplied Electricity

Do you know the effective heat generating seasonal efficiency?

No, use default value 0.7



Yes, seasonal efficiency is

7 Building Services – Lighting and Lighting Controls

The following guidance relates to a number of queries to the helpdesk and issues noted during audit.

7.1 Identification and proof for occupancy & photoelectric sensors

The following pictures show some common types of lighting sensors.

	<p>This T-5 light fitting has an in-built sensor. This sensor can perform dimming as well as presence detection. With this particular fitting the sensor can be also configured to provide just dimming or just presence detection depending on the application. Only LED's, T-5s or high frequency T-8 lamps have the capability to dim. Of course not all LEDs, T-5s or T-8s will have dimming hardware fitted to them.</p>
	<p>While this sensor is used for presence detection, its exact function can only be determined from manufacturer's data or from the test described later in this section.</p>
	<p>This fitting contains a microwave motion sensor. It is typically visible as a shadow on the fitting. If lights are found to operate automatically but a sensor cannot be observed, it may be that it is integral to a fitting, like this one. The Assessor must identify the presence of automatic lighting controls (e.g. by tests or documentation) rather than assume a shadow on a fitting is a sensor.</p>
	<p>Some sensors designed for corner mounting look similar to intruder alarm sensors.</p>

It is usually not possible to determine lighting sensor function from a visual inspection.

In conjunction with the guidance given in Section 7 of the NEAP Survey Guide, the method below will assist in identifying sensor types.

The following surveying method is suggested to identify lighting controls:

- 1) Turn on the lights and open any blinds in the room. You might wish to leave the room for 10 minutes to allow the system to stabilise.
- 2) Re-enter the room and observe if the lights are still on or if they switch on when you re-enter. This will test for occupancy control.
- 3) Observe which lights are switched on. Then close the blinds, if there are blinds. Observe any change to the lighting levels to identify photoelectric controls
- 4) If there are no blinds, shine a torch on the light sensor and observe if the lights tend to turn down or off. Then cover the light sensor with your hand and observe any changes to lighting levels to identify photo electric controls.

At this stage you should know the type of switching / dimming and the areas that are controlled. Note that there may be some delay built into both presence detection and dimming systems to prevent the lights ramping up and down excessively. This can happen, for example, with passing clouds and persons entering the space.

The results of the above test or similar test may accompany other site survey notes, drawings, specs and O&M (Operation & Maintenance) manuals (if available) to substantiate selection of a particular automatic lighting controls.

7.2 Entering a full lighting design

When carrying out a BER with plans and specifications available for the building a more accurate rating is obtained when “Full Lighting Design” is employed instead of selecting lamp types from the drop-down menu.

In order to use this method, obtain the lighting design figures (typically from the building services engineer).

Below is an example of the typical data that can be obtained from a lighting designer:

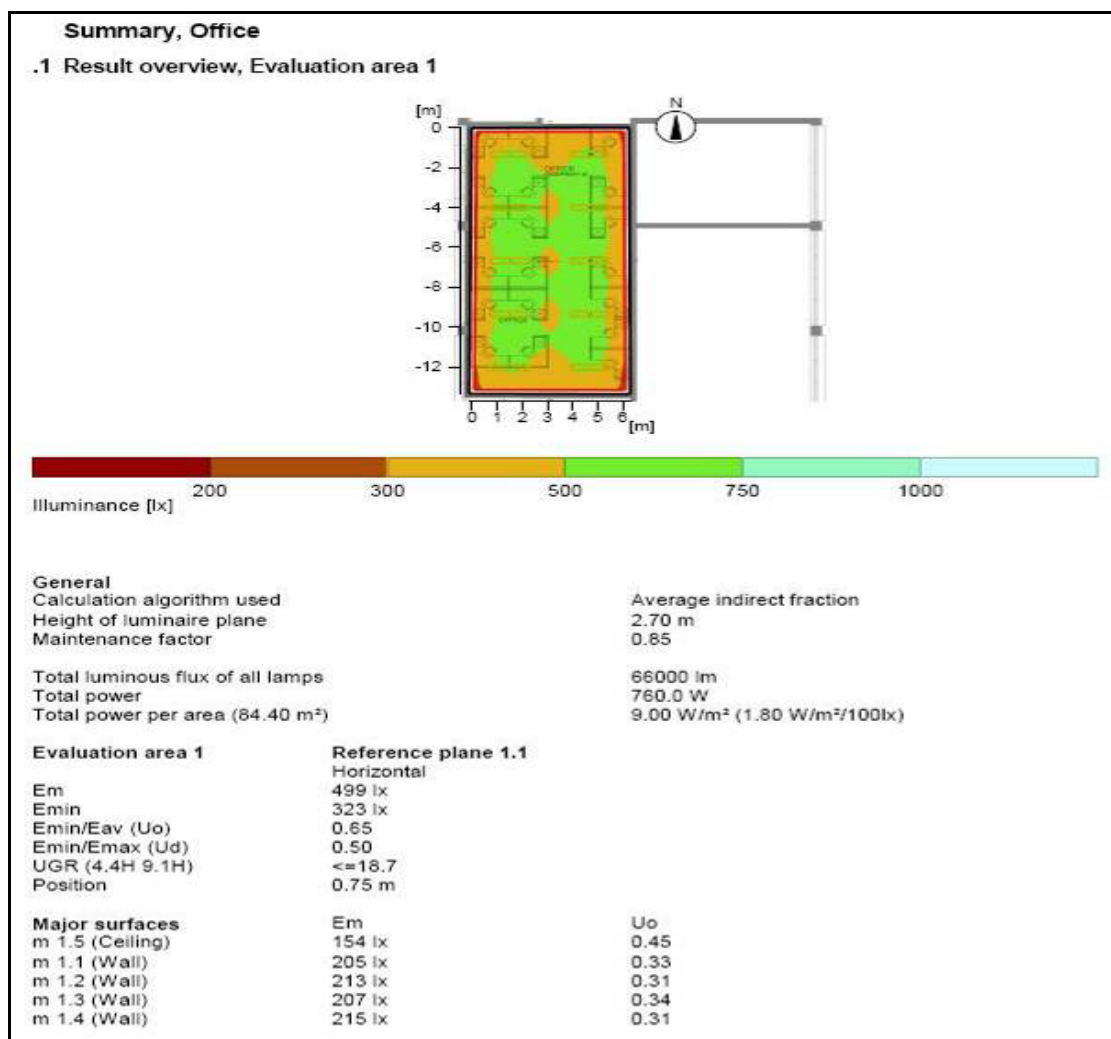

The figures used are:

The total power: = 760 Watts

The mean / average Lux (in this cases designated by Em): = 499 lx. If in doubt ask the lighting designer to clarify which figure represents the mean / average lux level.

The full lighting design data above is only for one area in a building. Relevant documentation for each zone is required if “Full lighting design carried out” is to be applied to all zones in an assessment.



The screenshot above shows the values in the lighting tab. It is important to also enter the actual lighting type even though the “Lighting parameters not available” field is not selected as the basis of the calculation. The lighting type in this case was T-5. Entering T-5 will prevent a “T-5 upgrade recommendation” being included in the Advisory Report which accompanies the BER Cert.

Documentary Evidence: In order to use the “Full lighting design carried out” entry the Assessor must have a signed statement from a partner/director of the consultants (normally the M&E (Mechanical & Electrical) engineers) responsible for the lighting design showing the installed power and design illuminance for each of the zones. Refer to Section 7 of NEAP Survey Guide for details on the required documentary evidence required.

7.3 Identification of Metal Halide, Tungsten Lamps & CFL Lamps

Recent audits have found issues with identifying the correct lamp types - in particular Tungsten Halogen with Metal Halide.

The SEAI website provides a number of lighting guides. These are useful in identifying different lighting systems: http://www.seai.ie/Your_Business/Technology/Buildings/Lighting.html and NEAP Survey Guide Appendix 11.

<p>Example 1</p> 	<p style="text-align: center;">Tungsten Halogen</p> <p>Example 1 The light source is more compact than standard tungsten filament lamps but is not regarded as low energy lighting. These lamps are entered into iSBEM as “Tungsten”. If uncertain, these lamps can be distinguished from Metal Halide by switching off and switching on again. Tungsten and tungsten halogen lamps will start instantly.</p>
<p>Example 2</p> 	<p>Example 2 This type of bulb has become more common and is a halogen replacement for a standard tungsten bulb. While this bulb is slightly more efficient than standard tungsten bulbs they still entered in iSBEM as tungsten, NOT CFL.</p>



Metal Halide

Metal Halides are a discharge type of lamp and therefore require warm-up time to allow them to reach their total luminosity.

They are not suitable for use with motion/presence sensors.

Some metal halide lamps are suitable for dimming with appropriate control gear.

If uncertain, these lamps can be distinguished from Tungsten by switching off and switching on again. They will require around a minute to restart and reach full brightness, unlike tungsten.

The bulb itself may need to be examined to be certain. If in doubt, use the higher energy option from the likely options.





Compact Fluorescent

In this example the lamp type might be expected to be Tungsten. Closer inspection reveals that the lamp types are CFL.

It is important to take a proper look at lamps when carrying out a survey.

CFLs are available in many shapes and sizes. If unable to determine whether a bulb is CFL or Tungsten, then the higher energy user (Tungsten) is specified.

7.4 Non Functioning Lighting

	<p>Some of the T-8 Fluorescent lighting in this assessment had been disconnected, as evident by cables hanging down. It is correct to include this lighting as T-8 Fluorescent rather than “don’t know” as the lighting is otherwise intact and could be reconnected by a new occupant.</p>
	<p>This light fitting is missing its bulb. Since the occupant has the choice to install Tungsten, CFL or LED the most pessimistic must be chosen for the purposes of assessment. The most pessimistic is Tungsten. “Don’t know” may also be chosen as its energy consumption equals that of tungsten.</p>
	<p>This light fitting is missing its tube. The Assessor is unlikely to know if the fitting is T-8 or T-12. The most pessimistic must be chosen for the purposes of assessment. The worst is T-12. “Fluorescent no details” may also be chosen as its energy consumption equals that of T-12</p>



Non Domestic BER Assessors – Technical Bulletin

Issue No. 2/14

December 2014

Contents:

1	General – NDBER Videos.....	2
2	General – Correctly Identifying Shell and Core.....	2
3	Building Services – Shell and Core HVAC, HWS and Lighting	3
3.1	Shell and Core HVAC and Activity	3
3.2	Shell and Core Hot Water.....	4
3.3	Shell and Core Lighting:.....	4
4	Geometry – Correct Measurement of Element Areas	6
4.1	Measurement of Wall Areas	6
4.2	Window Areas and Door Areas.....	8
4.3	Area Input Errors:.....	8
5	Geometry – Zone Heights, Additional Examples	9
6	Geometry – Merging Zones, Hotel En-suite Bathrooms	12
7	Geometry – Defining Zones, Chilled Rooms and Cold Rooms.....	14
8	Project Data Base – When Does U-Value Adjustment Apply?	16
9	Geometry – Windows, Area Ratio	17
10	Building Services – Entering HVAC Efficiency Values.....	18
11	Building Services – Finished Buildings with no HVAC.....	19

The Non-domestic BER Technical Bulletins are archived [here](#).

1 General – NDBER Videos

SEAI have completed a number of videos to assist BER Assessors with various aspects of non-domestic BERs. The first of these videos have been published on the SEAI website. Please see [here](#) for further details.

2 General – Correctly Identifying Shell and Core

A number of BER Assessors have asked the BER Helpdesk for clarification on how to identify shell and core buildings. Uncertainty can arise when a building is deliberately finished to shell standard only or has a very basic fit out such as for unconditioned storage or is unfinished due to lack of funding.

Examples:



Shell and Core, no HVAC or lighting

There are no Mechanical and Electrical services with the exception of drainage and a fire alarm. For this building, zones are speculative retail or speculative office type zones. The guidance in Appendix A4.8 of [the NEAP Survey Guide](#) is applied for Shell and Core buildings.



Completed warehouse zone, no HVAC, full lighting

This building has been completed. It is not Shell and Core. Final lighting is installed. There is no heating, nor is there a requirement for heating as it is a warehouse store. Lighting is entered as found. The heating to this zone is entered as “Zones without HVAC” in cases where there are other zones with heating in the BER assessment.

Note: If it happened that there were no other zones requiring heating or if this zone were the only zone in the assessment then, the “Notional Building” heating system as described in Section A4.9 of the NEAP Survey Guide applies.



Not completed, no HVAC, but full lighting installed

This building has been completed to the extent that it is not a Shell. Zone types can be identified. Final lighting is installed.

As there is no heating, but some zone activities require heating, assign appropriate HVAC default(s) based on NEAP Survey Guide Section A4.3.

It may not always be clear whether a building is classified as shell and core or as a completed building. As always, contact the BER Helpdesk when in doubt.

Note: Shell and Core buildings are only considered to be new-provisional ratings if the BER is published on the basis of plans/specs for a proposed construction. If a Shell and Core Building has been constructed already, a New-Final or Existing building BER applies. See the [October 2012](#) technical bulletin for further guidance on Shell and Core Buildings.

The type of rating published for Shell and Core Buildings follows the same guidelines as any other building, namely:

- New Building – Provisional Rating: A rating published on the basis of the plans and specifications for a proposed construction.
- New Building – Final Rating: A rating published for a building where construction is complete and has not been sold or occupied previously.
- Existing Building – Final Rating: A rating published for a building where construction is complete and it has been sold or occupied previously.

3 Building Services – Shell and Core HVAC, HWS and Lighting

Recent audits have identified some errors regarding the definition of the HVAC and lighting systems for shell and core systems.

NEAP Survey Guide Section A4.8 provides guidance on Shell and Core assessments. The following elaborates on the applicable guidance where there is no proposed design available.

3.1 Shell and Core HVAC and Activity

Refer to Appendix A4.8 of the NEAP Survey Guide. The following additional information applies to Shell and Core HVAC systems where there is no design detail available.

A HVAC system is assigned to every zone where the activity type selected for the zone is one typically requiring conditioning as detailed in A4.8.

If you cannot determine what activity will apply to a shell and core zone, it may be entered as a speculative zone such as “Speculative retail space”, “Speculative Industrial Space” or “Speculative office space”. There may be some circumstances where these speculative activities are not appropriate for the building type. In such cases, select the most appropriate activity type for the building.

Then apply the default system(s) from A4.8 to the zones as appropriate for zones typically requiring conditioning as outlined above.

3.2 Shell and Core Hot Water

A4.8 of the Survey Guide details the approach to HWS in Shell and Core Buildings. Where there is no design detail available:

- The system type will be “Instantaneous Hot Water only” (fuelled by electricity) or “Dedicated Hot Water Boiler” depending on the availability of electricity only or availability of other fuels.
- As there are no services installed in the Shell and Core unit, do not tick the “storage and secondary circulation” tab. Likewise, do not enter any “dead leg” lengths in the zone tab.

3.3 Shell and Core Lighting:

Refer to Appendix A4.8 of the NEAP Survey Guide. The following additional information applies to Shell and Core Lighting systems where there is no design detail available:

- Do not adjust the display lighting tab.
- If there is a possibility that an existing temporary lighting installation is extensive enough that it be considered as a permanent system, please contact the BER Helpdesk to review the details available if unsure of the approach to be taken.

Shell and Core HVAC Example:

A building has been constructed to a “Shell and Core” standard. The building is regarded as complete to the shell and core stage. There are capped floor drains, a fire alarm and a single halogen lamp for safe access with no other services installed. The only fuel on site is mains electricity.

The building requires a BER. There is no M&E design proposal at this stage.

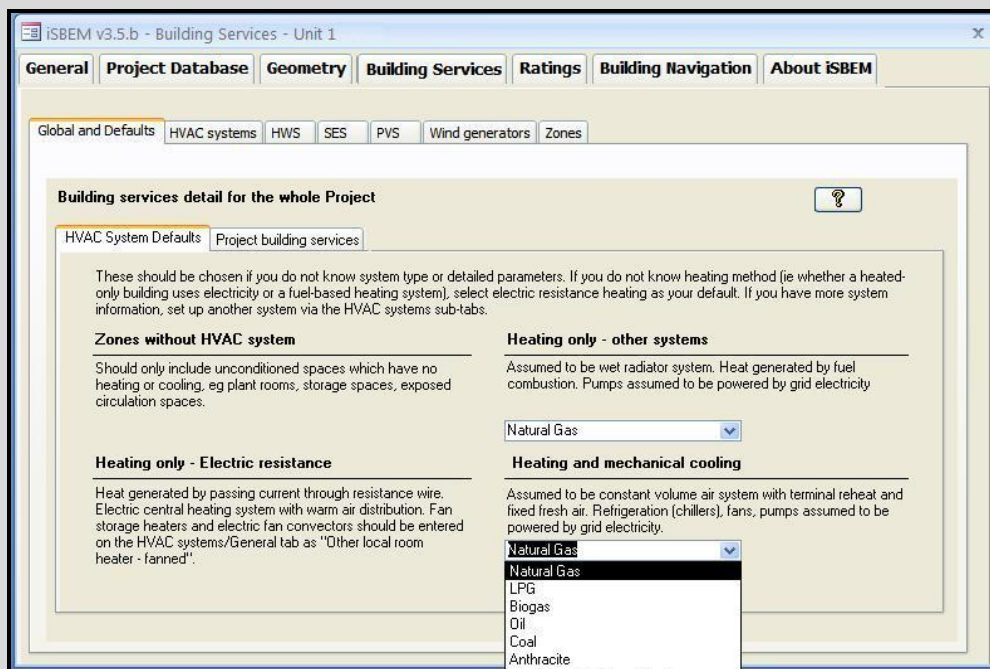

The HVAC system default used is “Heating and Mechanical Cooling”. Go to the Global and Defaults – HVAC System Defaults tab. In this example there is only electricity on site. There is no alternative fuel supply site. Natural Gas is selected as the fuel type even if there is no Natural Gas available. This is because there is no option to select electricity as the fuel type and Natural Gas is the fuel used in the Notional Building.

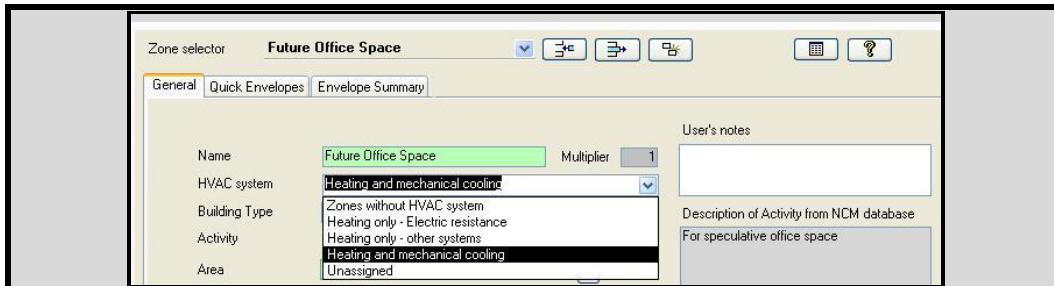

Assign Heating and Mechanical Cooling to the relevant zone or zones. “Heating and Mechanical Cooling” is a system built into iSBEM. It cannot be modified or deleted.

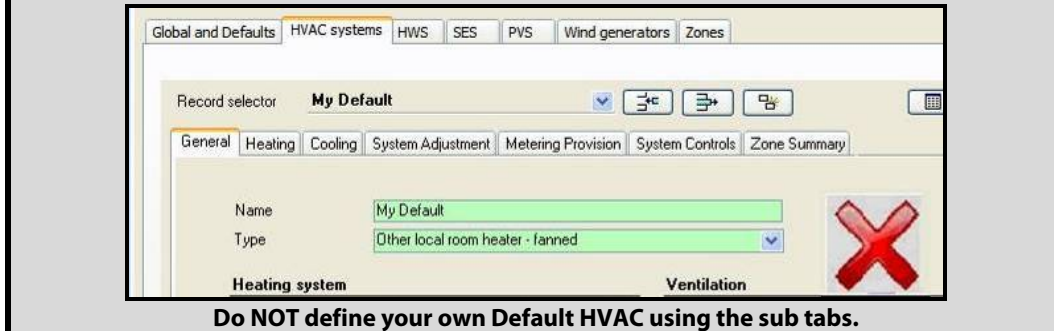

Do NOT define your own Default HVAC using the sub tabs.

Shell and Core Hot Water System Example:

For the same building as described above there are no water services in the building.

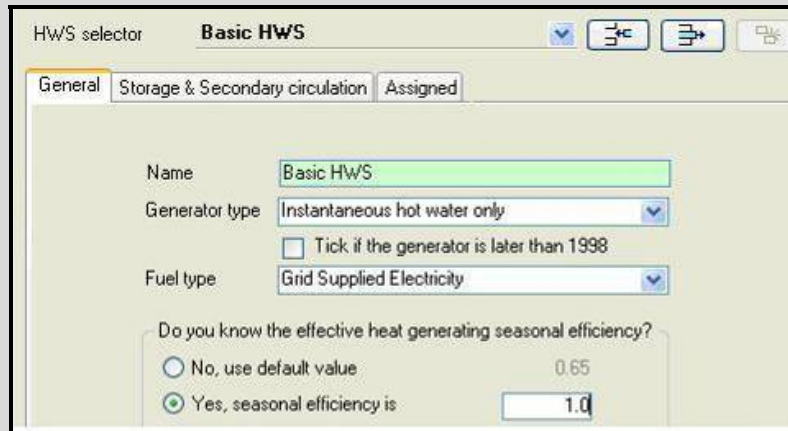

Define the hot water as “Instantaneous hot water only” with fuel type Grid Supplied Electricity as there is no other fuel available in this building. Remember to change the efficiency to 1.0 to represent the efficiency of direct electric heating. Do not enter anything in the Storage and Secondary Circulation Tabs. Assign this HWS to ALL of the zones in this shell and core assessment.

Shell and Core Lighting Example:

For the same building as described above, there is no permanent lighting, although the lighting to the unit next door is T-5 and it is expected that when this building will be fitted out it will be very similar to the building next door.

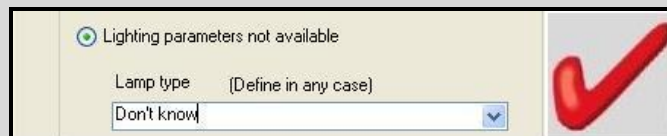

The correct choice is “Don’t know” as there is no documentation to show what is proposed.

● Lighting parameters not available
 Lamp type (Define in any case)
 T5 (16 mm diameter) triphosphor coated fluorescen

X

The presence of T-5 lighting next door must NOT be viewed as sufficient evidence to show that this building will also have T-5 lighting.

4 Geometry – Correct Measurement of Element Areas

Recent audits have found some geometry based errors in assessments. This section outlines relevant measuring conventions and how to avoid some common pitfalls.

4.1 Measurement of Wall Areas

For walls, the measurement is taken from the inner face of the exterior wall or party wall but to the centre of an internal wall forming the boundary to another zone within the assessment. Refer to Section 3.4 of the iSBEM User Guide, "Measurement and Other Conventions".

Examples:

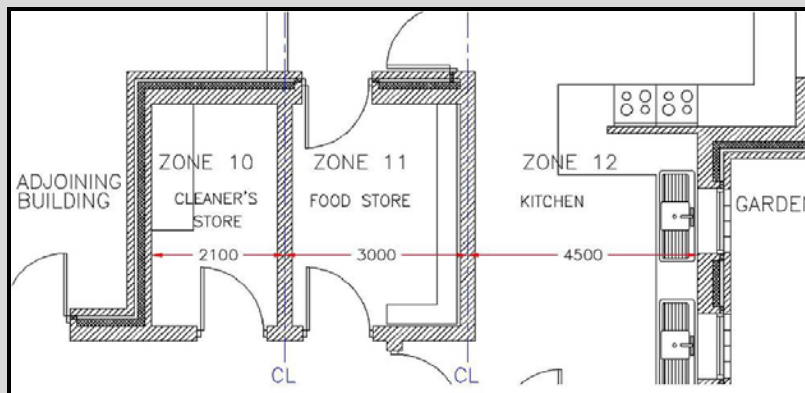

External and internal walls

External or party walls bounding adjoining buildings are measured from their inner face. For internal walls representing zone boundaries, measure to centre of the wall, shown as CL in the above sketch. Subsequent element area calculations carried out by the Assessor, are the basis for the element area entries in iSBEM.

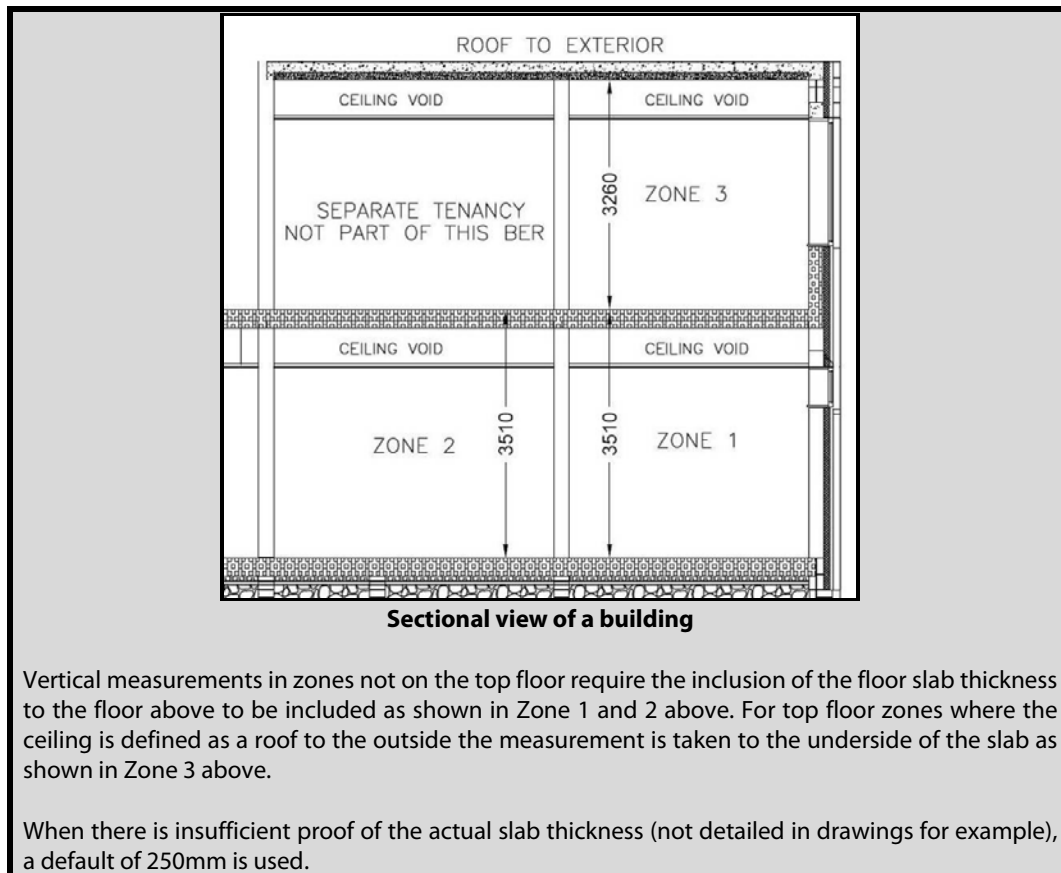

4.2 Window Areas and Door Areas

The area of an external window or a door is not subtracted from the wall element by the Assessor. iSBEM automatically subtracts the window or door area from the wall area. As per Section 7.5.5 (5) of the iSBEM User Guide, if an entered window or door area exceeds the area of the wall element to which it is applied, SBEM automatically increases the wall area to match that of the window/door areas. This leads to an inaccurate rating as the next example illustrates.

Example:

Many industrial and commercial units have block wall at lower level and prefabricated panel walls above this. Each side with this construction type has two wall elements.

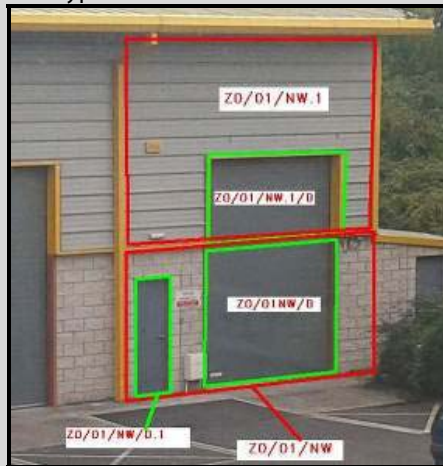

Where a large vehicle access door is present in such a building the correct way to enter the door is as two doors each of which represents the area occupied by the section of door in each section of wall. If the whole vehicle access door were applied to wall Z0/01/NW its area might exceed the area of the wall itself. SBEM would then increase the wall area to that of the door. This results in this zone having more external element area than actually exists. This increases heat loss from the zone resulting in a poorer BER.

4.3 Area Input Errors:

Recently, some audits have encountered area input errors whereby the zero key has been pressed instead of the decimal point key. The example below show the difference for a floor element changed from the correct value of 16.13 m² to 16013 m².

	Reference	Target	BER B-C	Actual		BER Label	
kWh/m ² /yr	175.72	175.72	227.96	303.95	C2	BER Label	
kgCO ₂ /m ² /yr	38.24	38.24	50.5	64.41	1.33	BER	
	Reference	Target	BER B-C	Actual		BER Label	
kWh/m ² /yr	8951.97	8951.97	8999.28	7986.42	B3	BER Label	
kgCO ₂ /m ² /yr	1658	1658	1669.08	1482.31	0.89	BER	

Errors of this magnitude are easily spotted on the ratings page where the building’s energy consumption in kWh/m²/yr and the kCO₂/m²/yr figure become unusually large. The change to the BER is unpredictable and depends if the relevant element is a wall, floor, roof or ceiling etc. It is good practice to also check inputs using the “Record” button at the bottom of the screen prior to publishing. The errant decimal point is spotted as the records are scrolled using the arrows.

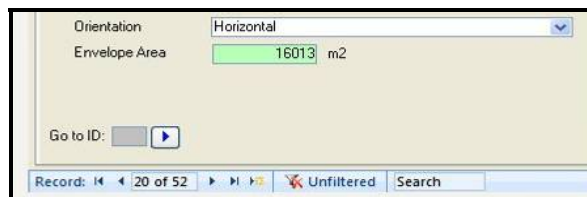

5 Geometry – Zone Heights, Additional Examples

Assessors have contacted the Helpdesk seeking guidance on zone heights. Appendix 6 of the NEAP Survey Guide provides relevant guidance. The examples below supplement the guidance in Appendix 6.

Pitched roof type buildings, multiple zones, full height boundaries

These are a combination of some of the examples in the NEAP Survey Guide.

Zone 1

- Zone 1 height is top of floor to weighted average height of all walls – h_{1av} . It has a mono-pitched ceiling.
- Area of each zone's gable wall is the zone's shaded area.
- Area of outer wall to zone 1 and zone 3b is h_4 x wall length.
- Area of any inner wall is inner wall height x wall length.
- U-value of Pitched Roof (U_{pr}) is from underside of ceiling to outside roof.
- Zone 1 Roof area is the roof width dimension Y_1 x building length.

Zones 2, 3a & 3b

- Zone 2 height is top of floor to weighted average height of all walls – h_{2av} .
- Zone 3a height is h_4 because the zone does not have a mono-pitched roof.
- Note: If Zone 3a & 3b were a single "Zone 3", that is if the dividing wall did not exist, then the zone height is h_4 because the zone does not have a mono-pitched roof.

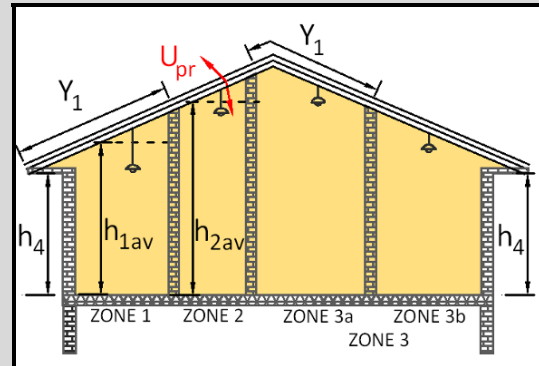

Example 1

Pitched roof type buildings, multiple zones, partial height boundaries, suspended ceilings

Example 2 and Example 3 are similar to the top floor with pitched roof and dropped ceiling example in the NEAP Survey Guide.

Suspended ceiling with or without insulation. Void above the zones not a useable space.

Zone 1

- Zone 1 height is top of floor to underside of soffit/eaves level h_4 .
- Area of gable wall is the zone's shaded area $L_1 \times h_4$.
- Area of outer wall is $h_4 \times$ wall length.
- Area of zone 1 inner wall is $h_{w1} \times$ wall length.
- U value of Pitched Roof (U_{r1}) is from underside of ceiling to outside roof.
- The Roof area is the ceiling width $L_1 \times$ building length.

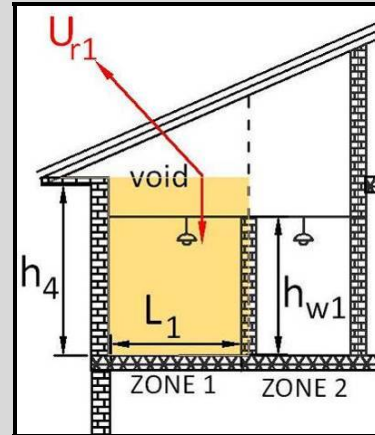

Example 2

Zone 2

- Zone 2 height is top of floor to underside of soffit/eaves level h_4 .
- Area of inner wall to zone 1 is $h_{w1} \times$ wall length.
- Area of inner wall to remainder of building is $h_4 \times$ wall length
- Area of gable wall is the zone's shaded area.
- U value of Pitched Roof (U_{r1}) is from underside of ceiling to outside roof.
- The Roof area is the ceiling width dimension $L_2 \times$ building length.

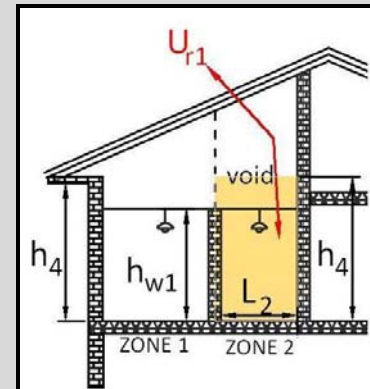

Example 3

Pitched roof type buildings, multiple zones, with horizontal boundaries**Zone 3**

- Zone 3 height h_3 is top of floor to top of floor slab as described in Section 4.
- Zone 3 Area of inner wall is $h_3 \times$ wall length.
- Zone 3 Area of outer wall is $h_3 \times$ wall length.

Zone 4

- Zone 4 height is the top floor soffit height - $h_{w(b)}$. It is not mono-pitched.
- Zone 4 Area of inner wall is $h_{w(a)} \times$ wall length.
- Zone 4 Area of outer wall is $h_{w(b)} \times$ wall length.
- Area of zone's gable wall is the zone's shaded area.
- U value of Pitched Roof (U_r) is from underside of ceiling to outside roof.
- The Roof area is the roof sloping width dimension $Y_1 \times$ building length.

Note: If Zone 4 had a mono-pitched roof the zone height would be the weighted average height.

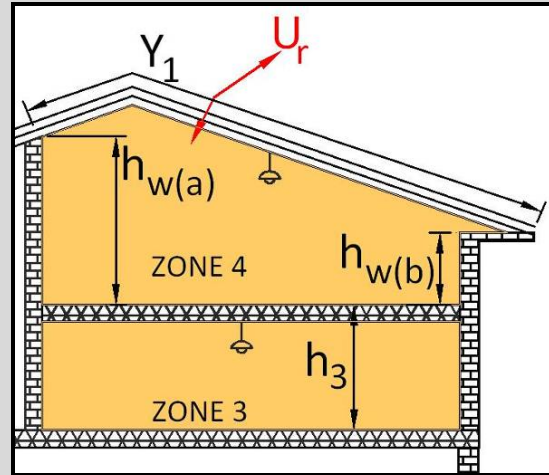
**Example 4**

6 Geometry – Merging Zones, Hotel En-suite Bathrooms

Assessors have contacted the help desk seeking assistance on BERs for hotels with a large number of rooms and zones. Hotels tend to have large numbers of similar sized and shaped zones. Assessors have asked for guidance on the potential to merge a hotel bathroom with its adjoining bedroom in order to reduce the number of zones in a project.

When zoning a building, follow Section 3.3 “How to Zone your building” in the iSBEM User Guide: “Merge any contiguous areas which are served by the same HVAC and lighting systems, have the same Activity within them (e.g., adjacent hotel rooms, cellular offices, etc.), and which have similar access to daylight, unless there is a good reason not to.”

The following sketches are from a hotel assessment. As is common in hotels, there is a repetition of the room layouts. Some layouts allow scope for more merging of zones than other layouts. In the examples below, it is assumed that all zones have the same lighting and HVAC. For these examples, the allocation of zones is then determined on activity and daylighting. Roof lighting arrays affect zone allocation, but there are none in these examples.

Examples:

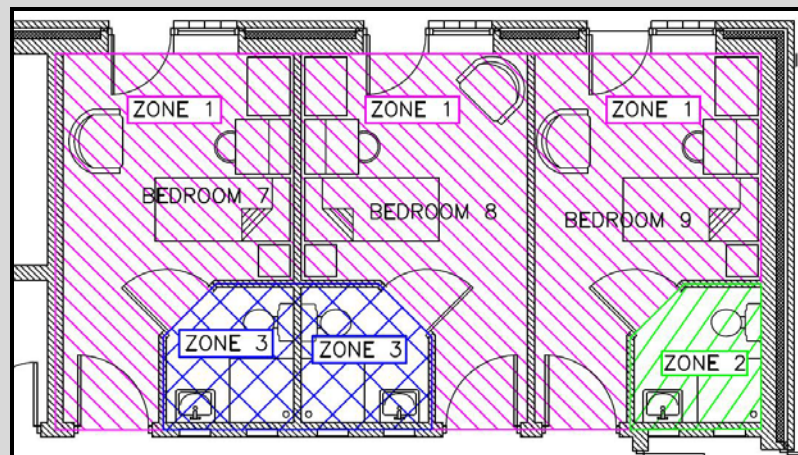

Example 1

Example 1: There are a total of six rooms. All have the same lighting and the same HVAC system. It is possible to reduce six zones down to three zones by merging following the iSBEM zoning rules. It is not possible to further merge the zones.

The three bedrooms can be merged into one zone as they are touching (contiguous), have identical HVAC, lighting, activity and their access to daylight is also identical. The bathrooms cannot be merged into the bedroom zones as they have a different activity to the bedrooms. Two bathrooms have been merged as they are contiguous. The third bathroom is not contiguous to another bathroom and so it must be defined as its own zone.

Be aware of the need to account for the thermal mass of the boundary walls between merged zones. If the walls are of a heavy construction they must be included as an additional element or elements assigned to the merged zone(s). If the walls are of lightweight construction, e.g. plaster stud they may be ignored subject to Section 3.3 par. 7 of the iSBEM User Guide.

Assessors have asked the BER Helpdesk if merging of vertically stacked zones is an option where identical layouts exist from floor to floor. Can a stack of three bedrooms each 3.0m high be merged into a single zone circa 9.0m high? No, it is not possible to merge zones in this fashion as the zone area will be incorrect and lighting allocation will be to a single tall zone rather than to the equivalent three 3.0m high zones.

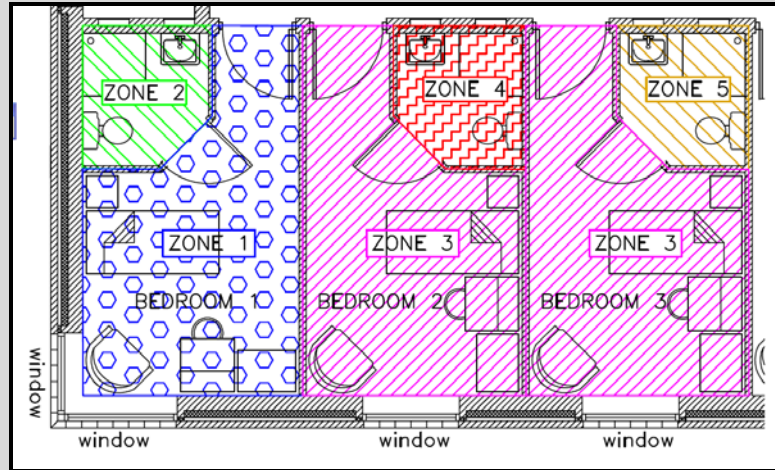

Example 2

Example 2: Again there are a total of six rooms. All have the same lighting and the same radiator based heating system. This example shows a more limited scope for merging and it is only possible to reduce six zones down to five zones by merging two bedrooms. It is not possible to further merge the zones.

The bathrooms have a different activity to the bedrooms and so cannot be merged with bedrooms. The bathrooms are not contiguous to neighbouring bathrooms and so cannot be merged and must be defined separately.

Bedroom 1 cannot be merged with bedrooms 2 and 3 as it has different access to daylight. Bedroom 1 has daylight from two sides while the other bedrooms have daylight from one side only.

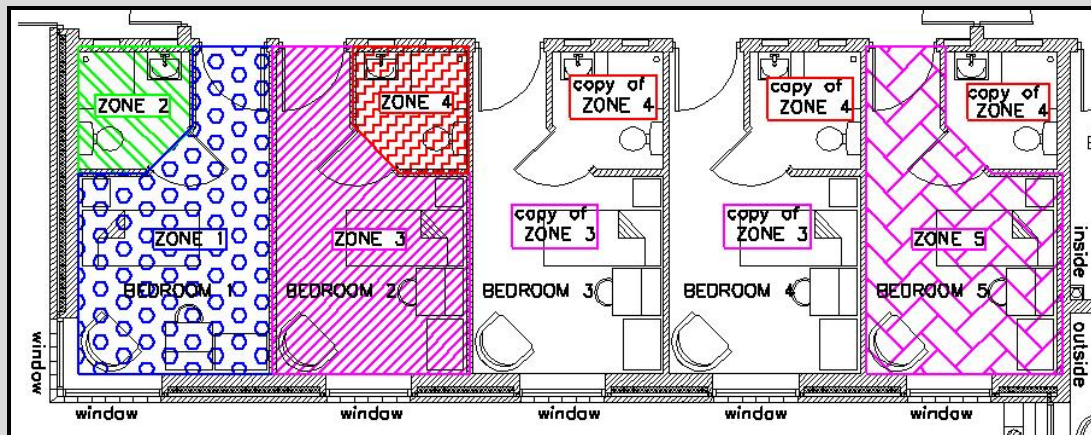

Example 3

Example 3: In situations like Example 2 above there is another option for Assessors to reduce the number of zones in SBEM by using the “multiplier” function. The multiplier function, when applied to a whole zone, multiplies envelope elements, energy uses etc. within in the zone. Use the zone multiplier with caution to avoid errors. The zones being copied must be fully identical. The zone multiplier value field is found in the zone definition tab for each zone. This mechanism helps where zone quantity is reaching the limit of iSBEM capabilities, as it does not create copies of zone elements.

In Example 3, Zone3 has been multiplied by 3 while Zone 4 has been multiplied by 4. Zone5 cannot be included as a copy of Zone 3 due to the right hand wall of Zone 5 having both inner and outer elements. In effect five zones have been entered instead of up to ten.

You may find that choice to use the methods employed in Example 1 and Example 3 to reduce the zone quantity will depend largely upon the layout being a “mirror image” type layout or an “identical” type

layout. It is permissible to use a combination of the two methods. Always document merging and zone multiplication clearly so that in the event of an audit the Assessor’s methods can be understood by the auditor and Assessor. Assessors’ use of the user’s notes text box can be helpful in understanding the method employed.

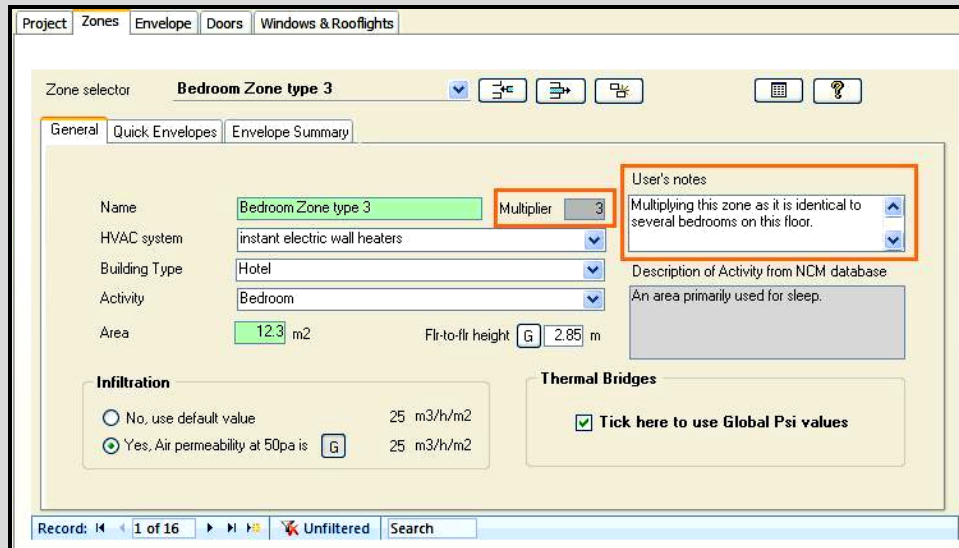

The screen shot above shows the location of the zone multiplier field and the “User’s notes” text box.

7 Geometry – Defining Zones, Chilled Rooms and Cold Rooms

Assessors have contacted the help desk seeking guidance when a building has a cold room. The following addresses a number of these queries.

Cold Room Example:

The following photograph and sketch show part of a fast food outlet. The food preparation area behind the counter has a free standing walk in cold room. The cold room (Zone 5) sits in a larger room – the food preparation area (Zone 4). In this example the top outer surface of the cold room does not touch the ceiling of the food preparation room. The food preparation room has a heating system.

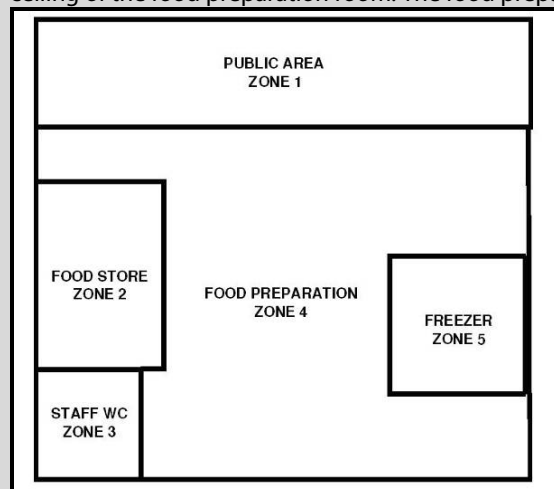

The cold room is zoned separately from the surrounding areas since it has a different zone activity associated with it, namely cold/chilled storage (Zone 5) and Food Preparation (Zone 4). Since the cold room temperatures are in this case below 0°C the zone is defined a Storage area - cold room (<0°C). Refer to the [Non-Domestic Technical Bulletin April 2012](#) Section 8 for information on selection of cold room or chilled storage zone types.

The zone height of Zone 5 is from the face of Zone 4's floor to the top outer surface of the cold room.

The cold room walls are most likely well insulated, but often an Assessor will not have the details of the insulation. When using default construction for the cold room walls, follow the methodology in A4.1 and A4.2 of the NEAP Survey Guide, using the Inference Method select "Metal Cladding system" as General Description and selecting the appropriate building regulations depending on the age of the building. If the cold room walls are proven to be insulated and the cold room is older than 1994, "Pre 1991" is selected. A similar approach is used for the cold room ceiling.

The cold room elements are known to be insulated in this example. In cases where there is no proof of any level of insulation, the cold room elements are assumed uninsulated as they are internal elements.

The cooling load in Zone 5 is assumed to be a process load and it should not be included in the calculation. Therefore "Zones without HVAC system" is applied to Zone 5.



The height of Zone 4 is the height of the zone measured similar to the convention in the NEAP Survey Guide Appendix 6: "Warehouses with unusable space above adjoining zone". The unusable space between the top of the cold room and the underside of the ceiling is considered to be part of Zone 4. All elements of this unusable space are assigned to Zone 4. For example the short section of Zone 4 wall visible above the cold room is assigned to Zone 4. The plaster ceiling in the space above the cold room is included in Zone 4's full ceiling element. The high level "floor" made by the cold room's top outer surface is assigned to Zone 4. For further guidance refer to NEAP Survey Guide Appendix 6: "Warehouse with unusable space above adjoining zone".

Zone 4 contains some elements adjoining the cold room, namely the insulated walls and the top outer surface (entered as an internal floor in Zone 4). These elements connecting to the cold room are assigned as "connects to unconditioned adjoining spaces" when assessing Zone 4, therefore requiring analysis for possible U-value adjustment. Please see the guidance and calculation tool to assist Assessors in carrying out U-value adjustments for elements adjoining unheated spaces using the relevant standards and guidance [here](#).

Note: If it happened that the notional building's heating system needed to be applied to all zones in the assessment in accordance with the guidance laid out in Section A4.9 of the NEAP Survey Guide, then the Notional System is applied to the cold room as well.

8 Project Data Base – When Does U-Value Adjustment Apply?

It has been noted by the helpdesk, and during audits, that Assessors sometimes adjust U-values when it is not necessary to do so. The following matrix outlines when an adjustment need or need not be considered when calculating heat losses to adjoining spaces.

-  Adjustment Not Required
-  Adjustment Required

Zone being assessed	Adjoining Condition	Same Space	Conditioned Adjoining Space	Unheated Adjoining Space	Strongly Ventilated Space	Exterior or Underground
Conditioned Space						
Zone without HVAC specified in iSBEM						

N.B. Refer to Appendix 8 of the NEAP Survey guide for assistance in defining when a zone is considered a conditioned or unconditioned space in relation to activity profile and temperatures.

From the Survey Guide: a) "Conditioned Adjoining Space" if the space adjoining the element (zx/xx/xi) has the same activity as the zone (zx/xx) or is normally heated to similar levels as the zone (i.e. heated to a similar temperature (+/-5°C) for 90% or more of the duration of the zone being specified.)

b) "Unheated Adjoining Space" or "Strongly ventilated spaces" if the above condition is not met.

Is an adjoining zone heated by a process considered to be a "Conditioned Adjoining Space"?

An adjoining zone with no heating other than heat from a process is considered a "Conditioned Adjoining Space", with respect to the zone under examination, only if heated to similar temperatures for 90% or more of the duration as set out in Appendix 8 of the NEAP Survey Guide based on the SBEM Activity Database. If in doubt, consider the space as an "Unheated Adjoining Space" connecting to the zone under examination.

Is an adjoining unheated zone with default heating system considered to be a "Conditioned Adjoining Space"?

If a default Heating/Cooling system is allocated to a zone from A4.3 or A4.8 of the NEAP Survey Guide, the zone is considered a "Conditioned Adjoining Space" only if heated to similar temperatures for 90% or more of the duration as set out in Appendix 8 of the NEAP Survey Guide based on the SBEM Activity Database. If in doubt consider the space as an "Unheated Adjoining Space" relative to the zone under examination.

Unheated building with the Notional Building's Heating System applied as per Survey Guide A4.9:

Where a building has no heating system or requirement for a heating system, then following Survey Guide A4.9, the whole building has the Notional Building's heating system applied in SBEM. This may be because the zones are entirely heated by process heat and/or have zones which do not require heating. As the BER is an asset rating we still assess the quality of the fabric. While all zones within the building have been assigned with a heating system, Appendix 8 must still be followed to ensure that the adjoining zone's activity is heated to similar levels in order to determine if the adjoining zone is a "Conditioned Adjoining Space" or "Unheated Adjoining Space".

In all cases, adjoining buildings are assessed in accordance with guidance in Appendix 8 of the NEAP Survey Guide.

Please see the Microsoft Excel spreadsheet and associated instructional document when carrying out U-value adjustments for elements adjoining unheated spaces using the relevant standards and guidance [here](#).

9 Geometry – Windows, Area Ratio

Auditors have found cases where Assessors sometimes omit the requirement to input the area ratio for rooflights. From Section 7.5.5 of the iSBEM User Guide: "Area ratio covered is the ratio of the roof area covered by an array of rooflights to the total area of the rooflight glazing. This parameter is active only if the envelope to which this window belongs has been defined as a roof, i.e., the window is in fact a rooflight."

The area ratio is used to define an area of roof considered to be covered by rooflights and so assists iSBEM with automatic zoning according to day lighting levels.

Example:

A modern warehouse sales building with T-5 lighting and dimming achieves a BER of $B1 = 0.64$ with an area ratio left as the default value of 1.0.

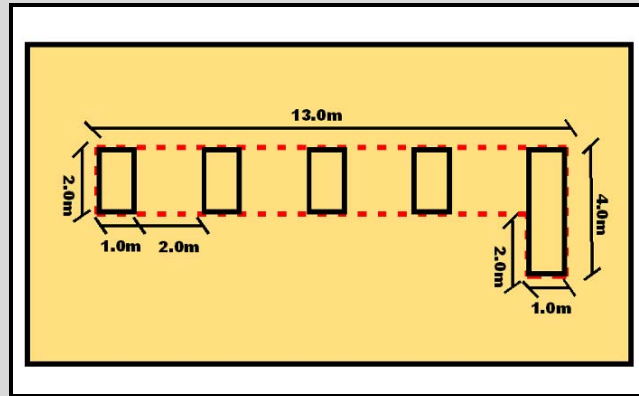

The roof area covered by the roof lights shown in broken line is 28m^2 . The rooflight area is 12m^2 . The area ratio is 2.33. When this is entered, the rating changes to $B1 = 0.6$ as the lighting load is reduced. This is because an area of the warehouse is well lit by incoming light from the rooflights array rather than the area lit by the rooflights localised in one smaller area.

10 Building Services – Entering HVAC Efficiency Values

Section 6 of the [October 2011 Technical Bulletin](#) and Section 6 of the [February 2014 Technical Bulletin](#) discuss entry of non-default seasonal efficiencies. When entering a non-default heat generating efficiency, always ensure the efficiency is entered correctly. For boiler efficiency enter the efficiency as a decimal 0.## rather than ##%. For Heat Pump COP enter as #.##. Always compare your entered figure to the default figure to check the entry is in the correct format.



In the screenshot above the right hand entry of 85 results in a boiler efficiency of 8500% instead of the intended 85% produced by the left hand entry. The right hand entry gives an incorrect appliance energy demand (1% of the correct figure) and will result in a rating being highly inaccurate.

Taking the above example, the two screen shots below show the results of entering the boiler efficiency correctly and incorrectly. The building is a refurbished 1900's building containing many original uninsulated walls, some tungsten lighting, but a reasonably efficient boiler.

Republic of Ireland: Building Energy Rating

Building Rating | Recommendations | EPC Audit | Calculation Logs | Calculation Errors | Supporting Documents

	Heating	Cooling	Auxiliary	Lighting	Hot Water	Total	
Actual	168.01	0	10.73	88.4	72.08	339.22	kWh/m2/yr
Reference	74.33	0	4.81	33.91	112.26	225.31	kWh/m2/yr
Notional	74.33	34.66	3.34	33.91	112.26	258.52	kWh/m2/yr

	Reference	Target	BER B-C	Actual		BER Label
kWh/m2/yr	309.8	309.8	399.44	531.75	C2	BER
kgCO2/m2/yr	75.65	75.65	84.12	129.04	1.33	BER

Correct: The energy consumption assigned to heating is higher than the notional building's heating consumption, due to the uninsulated walls but is a still reasonable value.

Republic of Ireland: Building Energy Rating

Building Rating | Recommendations | EPC Audit | Calculation Logs | Calculation Errors | Supporting Documents

	Heating	Cooling	Auxiliary	Lighting	Hot Water	Total	
Actual	1.68	0	10.73	88.4	0.72	101.53	kWh/m2/yr
Reference	74.33	0	4.81	33.91	112.26	225.31	kWh/m2/yr
Notional	74.33	34.66	3.34	33.91	112.26	258.52	kWh/m2/yr

	Reference	Target	BER B-C	Actual		BER Label
kWh/m2/yr	309.8	309.8	399.44	270.29	B2	BER
kgCO2/m2/yr	75.65	75.65	84.12	64.39	0.68	BER

Incorrect: In this version the boiler efficiency has been entered incorrectly effectively giving the boiler 8500% efficiency instead of the intended 85% efficiency.

The energy consumption assigned to heating is many times smaller than that of the notional building's heating consumption. This signals that there is something wrong with the assessment.

Always examine the SBEM Building Ratings tab carefully before publishing the BER.

11 Building Services – Finished Buildings with no HVAC

Assessors have contacted the BER Helpdesk seeking guidance on applying default HVAC to finished buildings. Please see below for examples based on these queries. This guidance does NOT apply to Shell and Core buildings or unfinished buildings. If you encounter a situation that falls outside these categories and require assistance, please contact the BER Helpdesk.

Example 1:

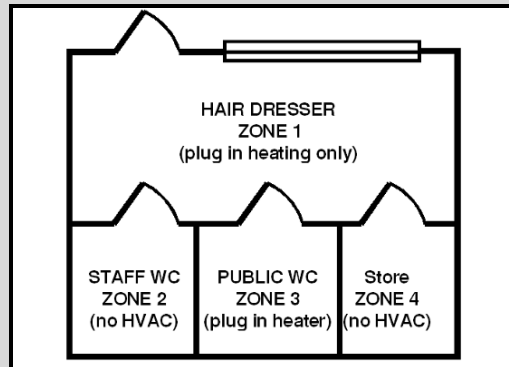

This is a sketch of a hair dresser's premises. There is no fuel other than electricity to the building and there is no fixed heating system; only portable plug in heaters.

Zone 1 is a general retail type zone and is expected to have heating in the NEAP methodology as it produces a red "!" when "Zones without HVAC" is applied. As outlined in the NEAP Survey Guide Section A7.2, A default must be selected from Section A4.3 of the NEAP Survey Guide for this zone. In doing so, the "Zone conditions" and "Building Conditions" in Section A4.3 must be read when selecting the default system. After consideration of "Zone conditions" and "Building Conditions" the default is: "Heating Only Electric Resistance".

The remaining zones are entered as zones without HVAC. While the unheated toilets produce a red "!" when "Zones without HVAC" is applied, they are transient and so do not have a default system applied to them as per the NEAP Survey Guide. The store does not produce a red "!" when "Zones without HVAC" is applied and so it is entered as "Zones without HVAC". If the toilets or store had a fixed system, it would be entered as found.

Example 2:

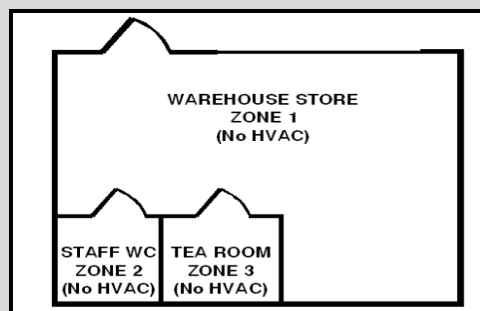

This is a sketch of a small warehouse. There is no fuel other than electricity to the building and there is no HVAC system of any sort in the building.

The warehouse store, Zone 1, will not produce a red "!" when "Zones without HVAC" is applied to it and so it will not have default heating applied from Survey Guide A4.3. The toilet and tea making zones will produce a red "!" but are transient and so these too will not have default heating applied as detailed in the Survey Guide Table A7.2. A heating system must still be applied to the building to produce an XML file for upload to NDNAS.

This building requires the application of the "Notional Building's" heating system. Refer to Appendix A4.9 of the NEAP Survey Guide. This type of system is applied to ALL zones in the building.

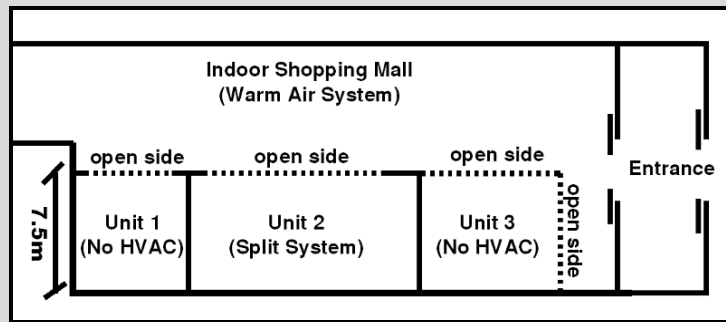
Example 3:

The sketch above shows a shopping mall with three units. Each unit is to be rented separately and each needs its own BER certificate.

In this case, a red "!" would apply to the retail units 1 and 3 if specified as "Zones without HVAC" in iSBEM. These retail units are not transient and are not process heated so a heating system must be applied in iSBEM. It is necessary to determine if these open sided zones are indirectly conditioned by adjoining zones, either within the same BER assessment or adjoining premises (most notably, the main shopping mall).

It is not clear that Unit 1 is indirectly conditioned by the mall. It is open on only 1 side and the system designer has not detailed that it is intended to be conditioned by the mall. Therefore Unit 1 has a default HVAC system from Survey Guide A4.3 applied in SBEM.

Unit 2 will have its own Split System applied as HVAC in its BER assessment.

In this case, the system designer has detailed that Unit 3 is to be conditioned by the Mall HVAC system. In addition, it is open on 2 sides to the Mall and is clearly operating at the same conditions as the surrounding mall.

The iSBEM User Guide Section 7.6.8 provides further guidance on identifying indirectly conditioned spaces.



Non Domestic BER Assessors – Technical Bulletin

Issue No. 1/15

December 2015

Contents:

1	<u>General – Audit Targeted Items</u>	<u>2</u>
2	<u>General – Choosing The Correct Building Type</u>	<u>2</u>
3	<u>General – Multiple Units in a Single Building.....</u>	<u>5</u>
4	<u>Project Database – Age Based U-Values.....</u>	<u>5</u>
5	<u>Project Database – Glazing Default Entries.....</u>	<u>7</u>
6	<u>Project Database – Connectivity to Adjoining Properties.....</u>	<u>8</u>
7	<u>Project Database – Elements containing voids.....</u>	<u>10</u>
8	<u>Geometry – Blocked up windows</u>	<u>11</u>
9	<u>Geometry – Small Zones.....</u>	<u>12</u>
10	<u>Geometry – Incorrect Roof area Entry</u>	<u>12</u>
11	<u>Geometry – Incorrect Orientation.....</u>	<u>13</u>
12	<u>Geometry – Incorrect skylight area</u>	<u>14</u>
13	<u>Geometry – Incorrect Wall area Entry.....</u>	<u>14</u>
14	<u>Building Services – Exhaust Systems.....</u>	<u>15</u>
15	<u>Building Services –Split / Multi Split Systems</u>	<u>16</u>
16	<u>Building Services – Radiators + Stove</u>	<u>18</u>
17	<u>Building Services –Finished Buildings with no HVAC.....</u>	<u>19</u>
18	<u>Code of Practice – Building Access for Audits</u>	<u>20</u>

The Non-domestic BER Technical Bulletins are archived [here](#).

1 General – Audit Targeted Items

Following analysis of audit findings in 2015, SEAI will be targeting errors in the following areas for audit. Assessors are advised to read the guidance associated with each of these areas to increase assessment accuracy.

Audit target area	Guidance areas
Building Services - Incorrect HVAC system selected	<ul style="list-style-type: none"> • iSBEM User Guide Section 7.6.2 • NEAP Survey Guide Appendix A4.3, A4.8, A4.9, A7 • Technical Bulletin October 2012, Section 1 • Technical Bulletin May 2013, Section 3 • Technical Bulletin February 2014, Section 6 • Technical Bulletin December 2014, Section 3.1, Section 11 • Non Domestic Assessor video : NEAP – HVAC and System Controls
Building Services - Incorrect HWS Generator Entered	<ul style="list-style-type: none"> • iSBEM User Guide Section 7.6.3 • NEAP Survey Guide Appendix A4.4 • Technical Bulletin January 2012, Section 1 • Technical Bulletin May 2013, Section 1, Section 2 • Technical Bulletin December 2014, Section 3.2 • Non Domestic Assessor video : NEAP – Hot Water Systems
Building Services - Incorrect Lighting entered	<ul style="list-style-type: none"> • iSBEM User Guide Section 7.6.8 • NEAP Survey Guide Appendix A4.10, A4.11, A11 • Technical Bulletin January 2012, Section 6 • Technical Bulletin May 2013, Section 4 • Technical Bulletin February 2014, Section 7 • Technical Bulletin December 2014, Section 3.3 • Non Domestic Assessor video : NEAP – Lighting and Lighting Controls
Envelope - Incorrect "Connects to" entered	<ul style="list-style-type: none"> • NEAP Survey Guide Appendix 8 • Technical Bulletin April 2012, Section 4 • Technical Bulletin February 2014, Section 3 and Section 4
Envelope - Incorrect Window/Rooflight Area entered	<ul style="list-style-type: none"> • iSBEM User Guide Section 3.4 • Technical Bulletin December 2014, Section 4 • Non Domestic Assessor video : NEAP – Zoning, Dimensions and Areas
Project Database - Floor Thermal Properties Incorrect	<ul style="list-style-type: none"> • NEAP Survey Guide Section 7 and Appendix 4 • Non Domestic Assessor video : NEAP – Building Fabric
Project Database - Roof Thermal Properties Incorrect	<ul style="list-style-type: none"> • NEAP Survey Guide Section 7 and Appendix 4 • Non Domestic Assessor video : NEAP – Building Fabric

As always, other items will be checked during the audit process but we wish to highlight the importance of the items listed in the table above given findings from recent audits.

2 General – Choosing The Correct Building Type

Assessors have contacted the BER Helpdesk for guidance on selecting correct building type for a particular building. It is essential to input the correct building type because the calculated energy use and BER grade can differ significantly between different building types. Each building type has specific operating hours and temperature set points built into the iSBEM activity database. These activity database parameters are not editable by the user. iSBEM assigns different parameters to, for example, a “cellular office” in a “Primary School” to a “cellular office” in a “Community Centre”.

When assessing a “mixed use” development, reference different building types to cover the various uses in the development. See Section 2 of the [January 2012 Technical Bulletin](#) for an example. The “Building Type” entered on the “General information” tab in iSBEM for mixed use developments represents the building type with the largest area in the assessment. The “Building Type” appears on the BER Certificate.

Section 2 of the [January 2012 Technical Bulletin](#) shows a list of building types available for selection in iSBEM. Assessors must document the reasons for specific choice(s) of building types.

Building Type Examples

It is important to note that a BER is an asset rating of a building, or part of a building, and not a measure of the efficiency of the actual activity taking place in the building. This means that the building is assessed based on building type. The current occupant's equipment or property not forming part of the lease / sale is omitted from the BER.

Example 1: Is this a warehouse or workshop?

This building is a large open plan type structure with a toilet towards the end. It has no installed heating system. Is this building better classed as a warehouse or a workshop?



In this case the assessor is told the vehicle mechanical lifts are the property of the previous tenant and are not part of the building. Ignoring the mechanical lifts, the building has task lighting and power points fitted to the walls. Due to the extra electrical fit-out, the building type is a "Workshop maintenance depot" building type rather than a "Warehouse and storage" building type.

There is another building type available called "Industrial Process Building". This building type is best suited for larger industry.

However if a smaller scale industrial development had zones such as a laboratory or a clean room, "Laboratory" is selected from the "Industrial Process Building" type to represent zones of this type.

Example 2: Is this a retail or primary healthcare building?



Exterior View



Interior View

There are a number of pointers indicating that this is a retail building rather than primary healthcare:

- It is located in a retail area
- The activity "hairdressers" is classified as retail as per Section 2 of the [January 2012 Technical Bulletin](#).
- There are no Primary Health Care specific zones in the building.

Example 3: Children's indoor play areas

Children's indoor play areas are often located in business parks and the building type "Retail Warehouse" is often the most appropriate. The best way to assess these types of businesses is to assess as if the play equipment were no longer present and take a view on what type the building is.

**Play Area****Snack Area**

For the above building the type “Retail Warehouse” is the correct choice. Unlike a typical warehouse, the building is conditioned and its lighting levels are higher than for warehouses. Its relatively large size means that “Retail” would not be the correct choice either.

Example 4: Crèches



Crèches and childcare: Use the building type “Community / Day Centre”. The childcare rooms themselves are best represented by the zone type “Workshop small scale”, as found in the “Community / Day Centre” building type. The reason the building type “Primary School” is not used for a crèche is because the iSBEM database of activities in includes school holidays while crèches generally stay open through the school holidays. “Community / Day Centre” building types do not have extended holidays.

Example 5: Is this an office, retail or primary healthcare building?

This building was in use as offices but a dentist then leased the building. Apart from installing the specialist equipment, such as the dentist’s chair, very little material alteration has been done to convert the building from offices to use by the dentist.



If the dentist were to leave, then the building would be suitable for office use without substantial work having to take place. Whilst frequently a dental practice will be in a retail building, this particular building is not suitable for use as retail due to its layout and location. Do not enter a dental practice as “Primary healthcare” unless the dentist surgery forms part of a primary healthcare complex and therefore has been specifically built for the purpose of healthcare.

Example 6: Buildings with cooling only

Food processing factories may have large work areas with cooling only. Since iSBEM HVAC systems all have a heating aspect to them, what sort of a system should be selected for this zone?



Factory floor of food processing plant

This type of zone has no installed heating system but is cooled for the purposes of the process taking place in it. With reference to Appendix A4.3 of the [NEAP Survey Guide](#), “Zones without HVAC” may be selected if it can be justified that a HVAC system is not required. This type of zone will be entered as a “Workshop Small Scale” and this zone definition will produce a red “!” When “Zones without HVAC” is applied. Since the space is being deliberately cooled for the purposes of the process there is no justification to apply a default heating system. The heating system for this zone will be “Zones without HVAC”.

While there is a zone type called “Industrial Process Area” it has substantial heat gains included which is not representative of a chilled workspace such as this. “Industrial Process Area” can be used in a factory where the machines such as ovens, are adding substantial heat to the workspace.

If unsure of the correct building type to select, contact the BER Helpdesk for assistance.

3 General – Multiple Units in a Single Building

BER Assessors have asked the helpdesk about the requirement for one or more BER certificates for large buildings consisting of several units - for example a shopping centre with multiple retail units. The Assessor must determine if a single BER can represent the entire building or if multiple BERs are required for the various units. The BER certificate should reflect the building or part of a building being offered for sale or lease. A building typically refers to the whole of a building or part of a building with the following options needing consideration:

- **Option 1:** A single BER to be produced for the entire building. In the event of leasing of the individual units, this BER can be used to represent these units as the BER is calculated on a per m² basis and the energy use is uniform.
- **Option 2:** A BER for each smaller unit. This will result in a number of BERs being produced to cover the entire building.

The BER Assessor should consult with the client with reference to their BER requirement for the building. Notwithstanding all of the above, the Building Control Authority (BCA) are responsible for ensuring that the BER is provided by building owners to prospective buyers and tenants. If in any doubt, the BER Assessor/client should consult with the BCA to confirm the number of BERs required for the building being assessed.

The [December 2014 Technical Bulletin](#), Section 11 and [February 2014 Technical Bulletin](#), Section 2 provide further examples of multiple units in a single building.

4 Project Database – Age Based U-Values

Recent Audits found some errors for U-values for elements selected based on building age. See Appendix 4.1 of the [NEAP Survey Guide](#) for guidance and examples. There are further examples in Section 3 of the [February 2014 Technical Bulletin](#). See the NEAP- Building Fabric video [here](#) for additional guidance.

The following examples are based upon recent audit findings.

Example 1: Internal Elements – “No date, uninsulated”

The internal wall shown below may or may not be insulated. It cannot be determined on site if it is insulated and no relevant documentary evidence is available.



Internal wall in a modern office, construction details unknown

In the absence of information available on site, or any supporting documentation, it must be assumed that insulation is not present. Appendix 4.1 of the [NEAP Survey Guide](#) advises: “For internal elements, irrespective of the adjoining condition, select “No date – Uninsulated” irrespective of the age of the building, unless able to demonstrate that insulation is present”.

Also, “The internal element U-value is adjusted as per Appendix 8 if adjoining an unconditioned space.” The internal walls for Example 1 are entered as shown below.

U-value	<input type="text" value="2.3"/>	W/m ² K	Sector	<input type="text" value="Office"/>
K_m	<input type="text" value="4"/>	kJ/m ² K	Building Reg Comp.	<input type="text" value="no date, uninsulated"/>
<small>Note that this value was called C_m in previous versions</small>			General Description	<input type="text" value="Framed / curtain walling"/>

This guidance applies to all internal elements and not just wall elements. If the element is connecting to an unheated space an R_u adjustment calculation is required subject to guidance in Survey Guide Appendix 8.

Example 2: External Elements – “No date, uninsulated”

The building shown below was built in the 1984. The owner said that the roof was insulated in 1995 when it was last renewed, and can remember that 25mm thick of polystyrene was added.

The Assessor has adhered to Section 2 of the [NEAP Survey Guide](#) and requested information from the client prior to carrying out the BER Assessment. In addition, following a site inspection, the BER Assessor still cannot source evidence to prove that insulation was added to the roof as it is hidden within the construction. The owner has no documents related to the roof renewal works.



1984 built retail unit

With reference to table in Appendix A4.1 of the [NEAP Survey Guide](#), the entry “No date, uninsulated” is chosen for the roof. This is because the building was built before 1994 and there is no visible or documentary evidence to allow the inclusion of insulation to the roof element. The roof is entered as shown below.

U-value	<input type="text" value="2.8"/>	W/m2K	Sector	<input type="text" value="Retail"/>
K_m	<input type="text" value="190.9"/>	kJ/m2K	Building Reg Comp.	<input type="text" value="no date, uninsulated"/>
<p>Note that this value was called Cm in previous versions</p>			General Description	<input type="text" value="Flat roofs Asphalt (or chippings on asphalt)"/>

“No date, uninsulated” also applies to the original walls, floor and door elements as there is no evidence to support the presence of insulation. Glazing is assessed as seen and/or measured on site.

Example 3: External Elements – “Pre 1991” age band

The building shown below was built in the 1940’s and renovated in the 1990’s. However, there is no evidence to support the actual year of the 1990’s renovation. It is immediately apparent from the drill holes that all of the cavity walls of the building were filled. The client does not know what sort of insulation was added to the cavities or the width of the cavity. Refer to the start of Section 7 of the [NEAP Survey Guide](#) for guidance on documentary evidence required to determine the age of a building.



1940’s built offices

With reference to table in Appendix A4.1 of the [NEAP Survey Guide](#) the entry “Pre-1991” is chosen for the exterior walls. Although the building was built before 1994 there is visible evidence to support the inclusion of insulation in the external wall elements. The walls are entered as shown below.

U-value	<input type="text" value="1"/>	W/m2K	Sector	<input type="text" value="Office"/>
K_m	<input type="text" value="129"/>	kJ/m2K	Building Reg Comp.	<input type="text" value="Republic of Ireland (pre 1991)"/>
<p>Note that this value was called Cm in previous versions</p>			General Description	<input type="text" value="Cavity wall, bricks/blocks"/>

Even though the assessor does not know the quality or quantity of insulation in the walls now “Pre-1991” walls are selected since “Pre-1991” elements assume that some insulation is present. If the attic is found to be insulated, but insulation details cannot be determined, then “Pre-1991” is used for the roof as well. In this example the BER Assessor cannot determine if the ground floors were ever insulated during renovations. The ground floor is therefore entered as “No date uninsulated”, similar to Example 2 above. The internal elements are entered as “No date uninsulated” unless site inspection or documentary evidence proves otherwise.

5 Project Database – Glazing Default Entries

See Appendix 4.2 of the [NEAP Survey Guide](#) for guidance on correct defaults for glazing. The following examples illustrate some common situations. The NEAP- Building Fabric Video [here](#) provides additional guidance.

Example: Metal framed double glazed window details unknown

This window is much newer than the 1970’s building it is in, but there is no information on site or elsewhere to confirm its date. There appears to be a coating on the glass when viewed from the side.



Aluminium frame, double glazed in 1970's building

In the absence of information on site, or any supporting documentation, default values are assumed.

- The glazing is assumed to be uncoated, air filled as the building was constructed prior to 2004 and there is no evidence to demonstrate that the windows are newer than that.
- Unless measured, the type 4-6-4 is assumed.
- It is possible to select an age for this aluminium window. Therefore select “pre-1995”.

It is entered as follows:

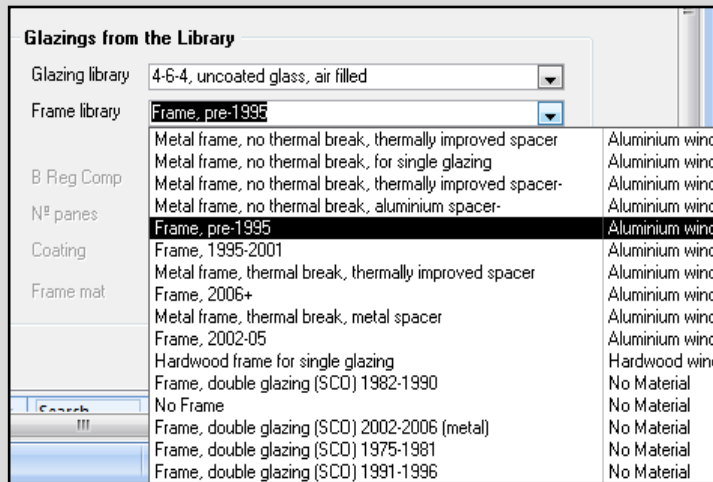

Ensure the frame material on the right hand side of the selection matches the frame material observed on site. Do not use selections referencing the Building Regulation of other jurisdictions. Refer to the start of Section 7 of the [NEAP Survey Guide](#) for guidance on determining the age of the building.

6 Project Database – Connectivity to Adjoining Properties

Recent audits found cases where the incorrect adjoining condition was specified in SBEM. See Appendix 8 of the [NEAP Survey Guide](#) for guidance on this issue.

The [February 2014 Technical Bulletin](#) Section 4 addresses domestic accommodation adjoining office accommodation.

Example 1: Retail with Apartments overhead

The building below consists of a retail unit with apartments overhead. The apartments are assessed using the DEAP methodology while the retail section is assessed using iSBEM.

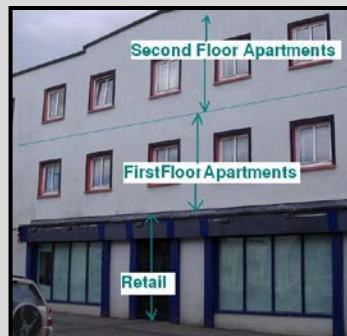

Retail unit with apartments overhead

The ceiling of the retail unit is entered as connecting to an unheated space. This is because the heating hours of the retail unit and the temperatures of the accommodation are NOT at a similar temperature ($\pm 5^\circ\text{C}$) for 90% time. It is possible to look up operating hours for particular combinations of buildings as

described in the [February 2014 Technical Bulletin](#). The table in Appendix 8 of the NEAP Survey Guide shows the Weekly Temperature Profile for common building types. See below for a graphical comparison of the two building types based on the information in the SBEM activities database using weekday figures as an example:

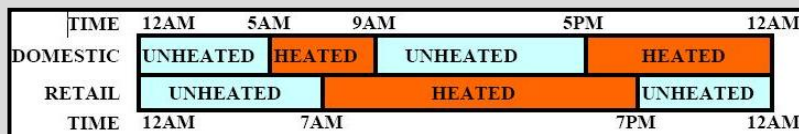

Therefore, the ceiling of the retail unit is connecting to space considered as unheated and an Ru adjustment is required. SEAI has published a Microsoft Excel spreadsheet and associated instructional document to assist assessors in carrying out U-value adjustments for heat loss elements adjoining unheated spaces using the relevant standards and guidance [here](#). This is aligned to Appendix 8 of the [NEAP Survey Guide](#).

The first step is to select the most suitable construction type in iSBEM to represent the ceiling of the retail unit.

The construction shown above is chosen as the unadjusted U-value as it is the most conservative applicable option with a U-value of 1.4 W/m²K. If the BER Assessor has also carried out the BER of the adjacent building the dimensional information from this other BER is used to assist with the Ru adjustment calculations. If a BER Assessor cannot access adjoining building(s) then the Ru adjustment is made based on external measurements. This procedure is described in detail in Appendix 8 of the [NEAP Survey Guide](#). Following this procedure the Ru adjustment spreadsheet is filled out as shown below. The dwelling interior is inaccessible in this case. A default of 2.0 W/m²K is used for the wall U-value as described in Appendix 8 of the [NEAP Survey Guide](#). However, the dwelling windows are determined to be aluminium. The date assumed is pre 1995 and the glazing units themselves are assumed to be 4-6-4 yielding their U-value of 4.755W/m²K similar to the example in Section 5 above.

Element Number	Area (m ²) of Element	Zone Name/Description of Unheated Space	External Element in Unheated Space	Area (m ²) of External Element	U-Value(W/m ² K) of External Element	Sum of (AxU) for External Element in Unheated Space	Ventilation Rate of Unheated Space (ach)	Volume of Unheated Space (m ³)	Ru Value	Original U-Value(W/m ² K) of Element	Adjusted U-Value(W/m ² K) for Element
Internal Ceiling Elements Adjoining Unheated Spaces											
1	130	z01/ci	Wall	115	2	283.494	3	468	0.174	1.40	1.13
			Roof	0	0					Km Value (kJ/m ² K) for Element	
			Window	11.25	4.755						
			Other	0	0						12.00

Screenshot of the SEAI-Published Ru calculation spreadsheet

The U-value changes from 1.4W/m²K to 1.13W/m²K. The roof is not included in this particular calculation because it is part of the second floor. It is known that there is a boundary separating the roof from the volume under consideration so only the heat loss elements and volume of the middle floor are considered. The volume itself is calculated from an external survey and is based on the floor area of the first floor multiplied by the estimated / measured height of the first floor. If the apartment were a single storey rather than two storeys, the roof would be included in the above calculation.

The Ru adjusted iSBEM entry is as follows:

Name

Generally used in floors that connect the zone to:

What would you like to do?

Import one from the library

Help with Inference procedures

Introduce my own values

U-value: W/m2K

k_m : kJ/m2K

Constructions from the Library

Category:

Library:

Sector:

Building Reg Comp.:

Example 2: Gym / Fitness Centre adjoining a workshop



The BER is to be carried out on the gym / fitness centre

The two building types under consideration are “Sports Centre / Leisure Centre” and “Workshop / Maintenance Depot”.

As before using data from the iSBEM databases, the above combination is illustrated as follows:

TIME	12AM	7AM	6PM	12AM
WORKSHOP	UNHEATED	HEATED	UNHEATED	
LEISURE CENTRE	UNHEATED	HEATED	UH	
TIME	12AM	6AM	9PM	12AM

With reference to the diagram above the heating time of the workshop is less than 90% of the heating time of the Leisure Centre and so when carrying out the BER for the Leisure Centre the Workshop will be classed as an “Unheated adjoining space” even if it has heating installed

However if a BER were to be carried out on the Workshop, the Leisure Centre would be seen as a “Conditioned adjoining space”. While we have just discussed the consideration of the different operating hours, the space heating temperatures also have to be considered in making the decision on whether a space is classified as heated or unheated. In this case the “Gym” zone in the “Sports centre/leisure centre” building type heating set point is 18°C while a workshop small scale zone from the building type “Workshops/maintenance depot” is also 18°C.

Building combinations not included in existing guidance can be referenced by BER Assessors in the iSBEM databases, as noted at the start of this section, or alternatively BER Assessors can contact the BER Helpdesk for assistance with a particular combination.

7 Project Database – Elements containing voids

Recent Audits found that voids in an element can sometimes be entered incorrectly. The following example illustrates constructions including voids.

Example: Room in Roof

The sketch below shows a top floor zone. The attic space above is not a zone included in the assessment floor area: it is a void. The spaces either side are not accessible. What “connects to” should be assigned in iSBEM to the ceiling and the walls adjoining these voids?

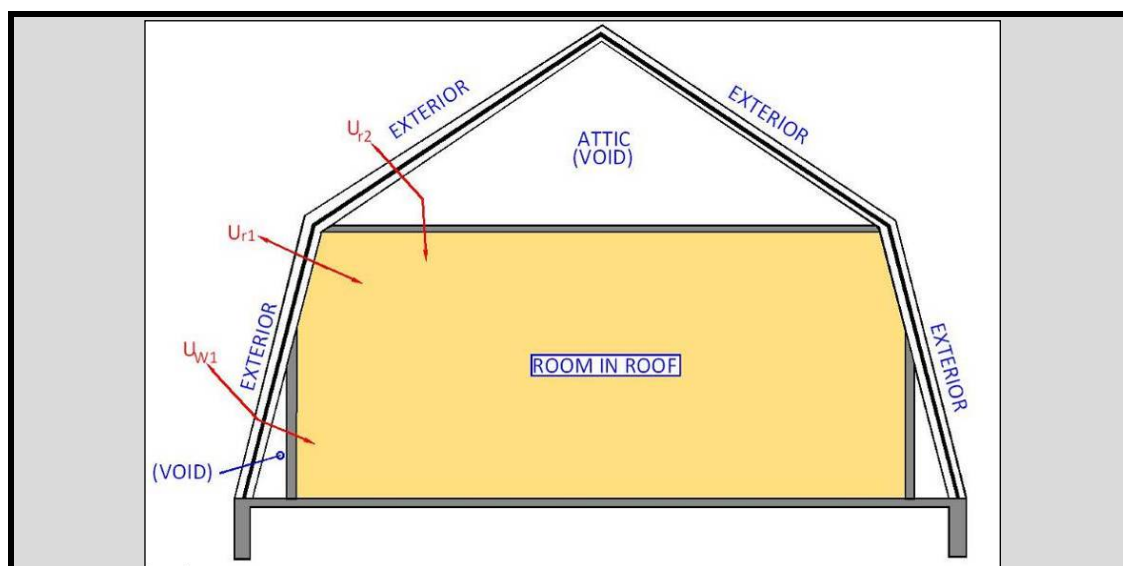

The “connects to” is to “exterior” as indicated by the red arrows. The construction of the wall or the ceiling with the void includes the air space as part of the construction. The U-value for these constructions, U_{r2} and U_{w1} , is calculated including the void and exterior façade.

Constructions from the Library

Category	Pitched roof, insulation at rafters
Library	Pitched roof, insul at rafters, uninsulated, L
Sector	Office
Building Reg Comp.	Republic of Ireland (2002)
General Description	Room in roof

A “Room in roof” element is available in the iSBEM data base for roof elements.

8 Geometry – Blocked up windows

Assessors may encounter buildings where the windows have been blocked up. There are a number of reasons why a building owner / occupier may have carried out this work. The following examples are common situations encountered and are intended to assist Assessors in deciding whether or not to include window elements. It is not possible to cover all situations in this technical bulletin. If Assessors encounter a situation for which they are unsure of the correct approach, contact the BER Helpdesk for assistance.

Example 1



Advertising films

The windows of this unit have had adhesive film attached to advertise its potential for lease / sale. With reference to “Window U-value, T-Solar and L-Solar” in Section 7 of the NEAP Survey Guide such films are ignored. The windows are entered in SBEM as if the film were not present.

Example 2



Plywood applied for security reasons

The windows of this building have been blocked up to prevent unauthorised access. In this situation the window will be entered as found and the plywood ignored. The reasoning is that this is a temporary measure and not part of the building fabric.

Example 3



Windows slabbed over with plasterboard

The windows of this building have been covered over with plaster board. In this situation the windows are ignored since substantial work will be required to reinstate them. The plasterboard construction is included in the assessment as another type of wall element.

9 Geometry – Small Zones

Recent Audits and queries to the BER Helpdesk have prompted this article on the practical application of the zoning rules. See Section 3.3 of the [iSBEM User Guide](#) for guidance on zoning. Section 6 of the [December 2014 Technical Bulletin](#) contains an example on zoning. The NEAP “Zoning, Dimensions and Areas” Video [here](#) provides additional guidance.

Example: A workshop with a small toilet

The drawing below shows a workshop with a small toilet in the corner. The toilet is 2.9m² and so when entered into iSBEM the following warning appears “Warning: Area seems small – are you sure?”

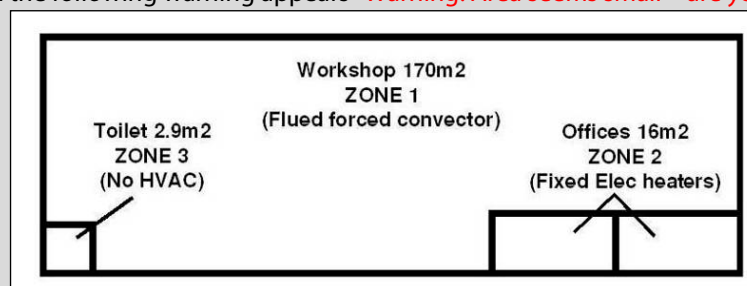

Sketch of the Workshop Building

A separate zone should still be created to represent the differing activity of the toilet compared to the surrounding workshop zone. The message “Warning: Area seems small – are you sure?” flags to the iSBEM user that the entered zone area is small in case the user has made an error during the area input. Since the toilet is unheated, the walls to the toilet, as seen from the workshop, require an Ru adjustment subject to the guidance in Appendix 8 of the NEAP Survey Guide.

10 Geometry – Incorrect Roof area Entry

Auditors have encountered the incorrect roof area entered where a roof is pitched. See Section 3.4 of the [iSBEM User Guide](#) for guidance on this issue and other iSBEM measurement conventions.

“Areas of floor, ceilings, and flat roofs are calculated in the same manner as the zone area. Area for an exposed pitched roof (i.e., without an internal horizontal ceiling) will be the inner surface area of the roof.”

Example: A zone with a sloped roof

The sketch below shows a cross-section of a building. The width of the building is 23.5m, as shown and the depth is 40m. The heights of the building are also shown. The roof pitch is 8 degrees.

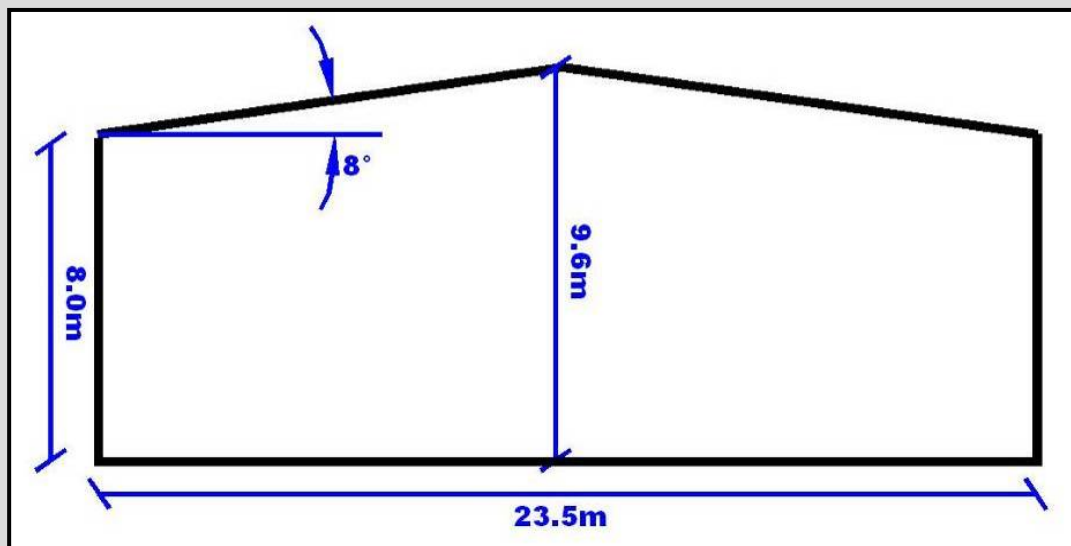

Sketch of Warehouse Building 23.5m wide and 40m long

The roof inner surface area is calculated as 948.7m² (based on the hypotenuse as the sloping roof x 40m depth. Multiply this by 2 to account for both sloping sections).

The floor area is 940m². The area of 948.7 m² is entered in the roof area field as shown below:

Envelope selector		z0/01/c	
General Window & Door Summary			
Name	z0/01/c	Multiplier	
Zone	z0/01		
Type of envelope	Roof	<input checked="" type="checkbox"/>	Is it Flat?
Construction	Roof unit 3k		
Connects space to	G Exterior		
Orientation	Horizontal		
Envelope Area	948.7	m ²	

In this example the “Is it Flat?” box IS ticked. This is because in iSBEM a roof with a pitch of less than or equal to 10 degrees is entered as a flat roof. A roof element with a pitch greater than 70 degrees is entered as a wall. See the end of Section 3.4 of the [iSBEM User Guide](#) for guidance.

11 Geometry – Incorrect Orientation

Auditors have encountered the incorrect orientation used for elements or for whole buildings. For some buildings, particularly buildings with a large amount of glazing, the orientation can result in a significant change to the BER. Always recheck the building’s orientation before commencing entering the building into the software. Always double check site notes against maps or other independent information sources.

It is possible to amend an incorrectly orientated building without having to re-enter all of the geometry. Section 7.5.2 of the [iSBEM User Guide](#) describes this procedure. It is however better to enter the correct orientation from the start since altering the orientation in iSBEM can be confusing.

12 Geometry – Incorrect skylight area

Section 4 of the [December 2014 Technical Bulletin](#) contains guidance on window and wall areas. The NEAP “Zoning, Dimensions and Areas” Video [here](#) provides additional guidance.

Example: Rooflight area calculation



Zone with rooflights

Occasionally rooflights or skylights are omitted in error. Always remember to look for rooflights during BER Assessments. Where elements are inaccessible due to height, use other measurable features on site to determine their areas. Document the methodology in case of future audit.

Section 9 of the [December 2014 Technical Bulletin](#) contains guidance on the correct entry of the window area ratio.

13 Geometry – Incorrect Wall area Entry

Section 4 of the [December 2014 Technical Bulletin](#) covers some measurement conventions for wall areas. The following example demonstrates use of these conventions. The NEAP “Zoning, Dimensions and Areas” Video [here](#) provides additional guidance.

Example: Wall area calculation

Zone with non-rectangular wall and a window

The zone is bounded on the left by the exterior and on the right by the adjoining zone. The length of the wall is measured from the internal face of the outside wall to the centre of the internal wall separating the adjoining zone.

The window area is NOT subtracted from the wall area calculation as iSBEM does this automatically. Using the dimensions given the wall area entered into iSBEM is calculated as follows:

$$(4.8\text{m} \times 10.5\text{m}) + ((0.5 \times 10.5) \times (8.6 - 4.8)) = 70.35\text{m}^2$$

The hatching in the diagram above represents the entered wall area. Refer to Sections 4 and 5 of the [December 2014 Technical Bulletin](#), Appendix 6 of the [NEAP Survey Guide](#) and Section 3.4 of the [iSBEM User Guide](#) for guidance on measurement conventions in iSBEM.

14 Building Services – Exhaust Systems

BER auditors have recently identified errors relating to exhaust systems, such as exhaust systems entered as ventilation systems or omission of exhaust systems altogether. The “Ventilation” Video [here](#) provides additional guidance.

Exhaust systems are often found in the following types of zones: Kitchens, Toilets (particularly toilets without windows), enclosed store rooms, workshop areas.

Exhaust systems must not be confused with ventilation systems. Exhaust systems extract air only, whereas ventilation systems have both supply and extract. Ventilation systems must only be entered where there is clear evidence of a supply, such as a second grille, duct or fan supplying air to the space by mechanical means. It is unlikely that you will encounter a situation where a zone had both “Ventilation” (supply and extract) and also had an “Exhaust” system serving the same space. If you encounter an unusual situation with regard to ventilation and exhaust contact the BER Helpdesk for assistance.

Documentary evidence to support the inclusion or exclusion of an extract system can be met by one of the following:

- As built mechanical drawings marked up showing zones.
- Survey form and photographs

See section 7 of the [NEAP Survey Guide](#) for further details.

Example 1

An extract disc to office toilet ceiling. The dust residue pattern around the disc indicates extract. There is no supply grille evident so the system is entered as “Exhaust” only.



If an internal toilet is encountered then it is likely there will be an extract fan. Only enter this exhaust if it exists.

Example 2

A restaurant kitchen. This space has Exhaust only. For this kitchen, the make-up air for the space is obtained by opening the end outside door which is fitted with an insect screen. There is no supply fan, supply duct, or grilles evident so the system is entered as “Exhaust” only.

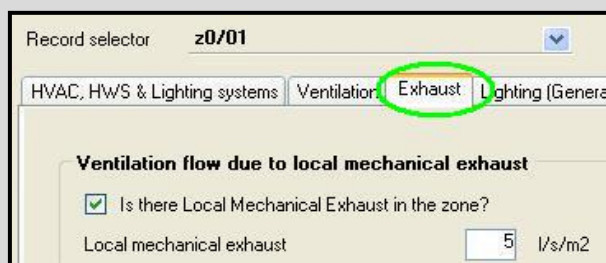

The exhaust encountered in examples 1 & 2 above is entered using the “Exhaust” sub-tab.

Example 3

Office with supply and extract grilles. Enter as “Ventilation”. Since “Ventilation” includes both Supply and Extract this means that an “Exhaust” entry is not required. In this case, the supply grille is the louvered grille while the extract grille is an “egg-crate” grille.

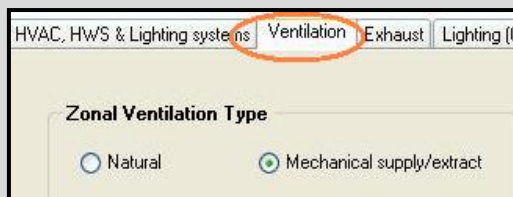
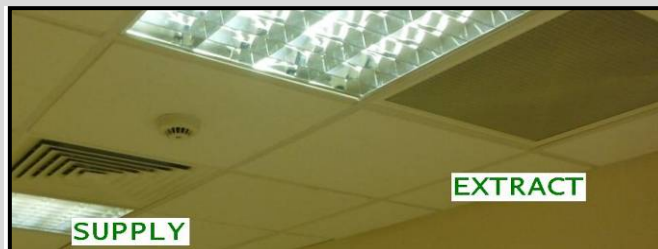

The ventilation encountered in example 3 above is entered using the “Ventilation” sub-tab.

15 Building Services –Split / Multi Split Systems

Recent Audits identified some incorrect entry of split / multi-split systems. This article aims to assist BER Assessors with the correct identification and entry of these items.

- The word “Split” means that the system is split in 2 parts, indoor unit and outdoor unit.
- Units may provide both heating and cooling or just cooling.
- There are indoor unit(s) connected to outdoor unit or units by lengths of copper pipework.
- Pipework usually consists of one smaller and one larger diameter pipe.
- Indoor units can be visible in the space or hidden in a ceiling void.
- Inspect the ceiling void if it can be done safely.
- Refer to Section 4.6 of the [NEAP Survey Guide](#) for details on inspecting above ceilings.

**Wall mounted indoor unit****Floor mounted indoor unit****Cassette type indoor unit****Concealed above ceiling indoor unit**

- Outdoor units can serve a single indoor unit.
- Where multiple indoor units are served by a single outdoor unit, this is a multi-split system.
- The outdoor units shown below are “air source” heat pumps.
- They gather and reject heat to the external air.

**Single -Split outdoor units****Multi-Split Outdoor units,
(bigger than single split outdoor units)**

If you identify a split or multi-split indoor unit, then it is necessary to find the corresponding outdoor unit(s). A single split system will have one outdoor unit for each indoor unit. A multi-split system will have more than one indoor unit connecting to an outdoor unit capable of serving the load of the multiple indoor units.

- Document details from each data plate / sticker.
- Try to find the combination on the ECA / ETL website or on the Eurovent Website. Refer to the [April 2012 Technical Bulletin](#) and the [February 2014 Technical Bulletin](#) for guidance.
- If the indoor / outdoor combination on site cannot be found, then contact the manufacturer/supplier to find suitable test data.
- If the combination of units still cannot be found, defaults are used.

If a BER Assessor encounters an item or items of plant that are unclear, then contact the BER Helpdesk for assistance with identification. The NEAP “HVAC and System Controls ” Video [here](#) provides additional guidance.

16 Building Services – Radiators + Stove

Section 7.6.2 of the [iSBEM User Guide](#) details a bivalent calculation where the HVAC is a combination of Gas Boiler and Air Conditioning. Following queries to the BER Helpdesk regarding the approach taken when other heating combinations were present, this Technical Bulletin provides an example detailing a bivalent system consisting of a stove and radiators heated by a gas boiler.

Example: Bivalent heating using radiators and stove

In an area of a public house there is a stove and radiators. The radiator based system is served by a natural gas fired boiler with a seasonal efficiency of 85.5%. The percentage split of the annual heating demand between the stove and the radiator system is unknown.



A Bivalent Heating System must be created to serve this zone.

As stated in [Non-Domestic Technical Bulletin May 2013](#) Section 3.3 - Bivalent heating systems:

“If assessors are unable to determine the load profile of each system they can assume that the split between the systems is equal (for example between two systems the split is 50:50).” In this example, it is not possible to determine the actual proportion of heat demand for each HVAC system. Assume a 50:50 split, as per the guidance.

If the stove was on its own, it would be entered as a “Room Heater” in iSBEM. The default seasonal efficiency for a “Room Heater” in iSBEM is 0.7 and so this is what is used in the bivalent calculation below for the seasonal efficiency of the stove.

The Bivalent system is calculated based on the equation from the [iSBEM User Guide](#):

$$SEff_{equivalent} = \frac{EmissionFactor_{Gas}}{\left(\frac{EmissionFactor_{SolidFuel} \times Load_{Stove}}{SEff_{Stove}} \right) + \left(\frac{EmissionFactor_{Gas} \times Load_{Boiler}}{SEff_{Boiler}} \right)}$$

See Table 2 of the [iSBEM User Guide](#) for the fuel emissions factors.

The CO₂ emission factor for Natural Gas is 0.203 kgCO₂/kWh.

The CO₂ emission factor for Dual Fuel Appliances (Mineral + Wood) is 0.289 kgCO₂/kWh.

Refer to the guidance in Appendix 10 of the [NEAP Survey Guide](#) for guidance on selection of solid fuel types.

$$SEff_{equivalent} = \frac{0.203}{\left(\frac{0.289}{0.7} \times 0.5 \right) + \left(\frac{0.203}{0.855} \times 0.5 \right)} = 0.624$$

The bivalent HVAC system is entered as follows:

BER Assessors occasionally ask how to identify the fuel for the “bivalent boiler”. The fuel selected is based upon the top line of the bivalent equation. In this case the top line uses the emission factor for Natural Gas and so Natural Gas is the chosen fuel. Selection of the gas boiler here will also allow iSBEM to take account of the auxiliary energy associated with the boiler circulation pump.

The Bivalent Efficiency calculated above is entered in the Heating sub-tab, “Effective heat generating seasonal efficiency” as shown below:

The resultant bivalent efficiency of 0.624 is lower than the boiler on its own, 0.855, as the stove (less efficient) is deemed to meet half of the demand in the absence of further detail on the load profile.

17 Building Services –Finished Buildings with no HVAC

Some completed buildings have no HVAC systems. When an unheated building is sufficiently complete that it is not considered “Shell and Core”, the type of system default is selected from Appendix A4.3 of the [NEAP Survey Guide](#).

Section 11 of the [December 2014 Technical Bulletin](#) details how to treat completed buildings without HVAC. The NEAP “HVAC and System Controls” Video [here](#) provides additional guidance.

Example : Finished Building with no HVAC

This building was built in the 1900’s. All elements are selected as “no date, uninsulated” as there is no evidence of insulation.

This unit has two zones namely the main sales area and a store room. There is no heating system. The unit is not shell and core. Electricity is the only fuel supplied to the unit. There is separate domestic accommodation above and to the rear of the unit.



Retail unit, Zone “Sales area general”

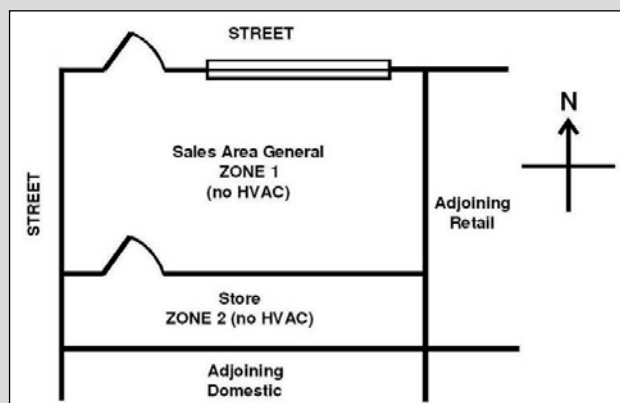

Sketch of the above retail unit

Since Zone 1 has an activity that produces a red "!", a default system is selected from Appendix A4.3 of the [NEAP Survey Guide](#). As per the building condition and zone conditions in Appendix A4.3, the correct system to select is "Heating Only Electrical Resistance". Zone 2 is a store room and so "Zones without HVAC" is used in Zone 2.

An Ru adjustment may be required for the south facing wall of zone 1 adjoining the store as it is a wall in a heated space connecting to an unheated space. An Ru adjustment may be required for the ceiling of Zone 1 as it connects to domestic accommodation above and has heating entered according to A4.3. Ru adjustments are not required for any other elements in Zone 1 and none in Zone 2, since Zone 2 is unheated.

Refer to Appendix 8 of the NEAP Survey Guide and Section 8 of the [December 2014 Technical Bulletin](#) to determine if and when the U-value adjustment must be applied.

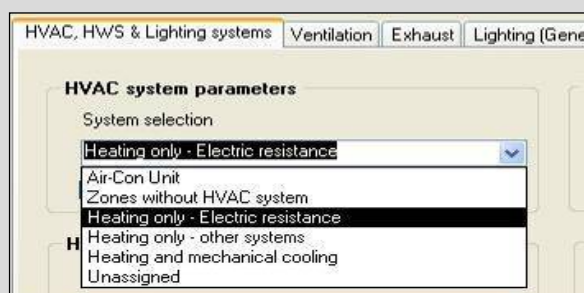

Default heating system for Zone 1.

The default systems are available for use in every iSBEM BER project and are not defined by the user.

18 Code of Practice – Building Access for Audits

The Code of Practice for BER and DEC Assessors is [here](#) and this forms the basis of the Quality Assurance and Disciplinary Procedure [here](#).

SEAI carry out audits on an ongoing basis to maintain the integrity of the BER scheme. Occasionally Auditors encounter situations where the assessor does not respond within the allocated time.

In the case of a documentation and practice audit, the BER Assessor is required to arrange access to the building in reviewing compliance with requirements. Occasionally the BER Assessor may not be able to arrange access. In such cases, the BER Assessor is required to provide documentary evidence supporting the request to gain access and the response from the client in order to support failure to access this property.

In accordance with Section 21 (Amendments to the Code of Practice and Directions) of the Code of Practice, SEAI may consider further amendments to the Code of Practice to ensure compliance with this requirement.